

**COLOR INKJET PRINTER**

***TS300P-1800***

**OPERATION MANUAL**

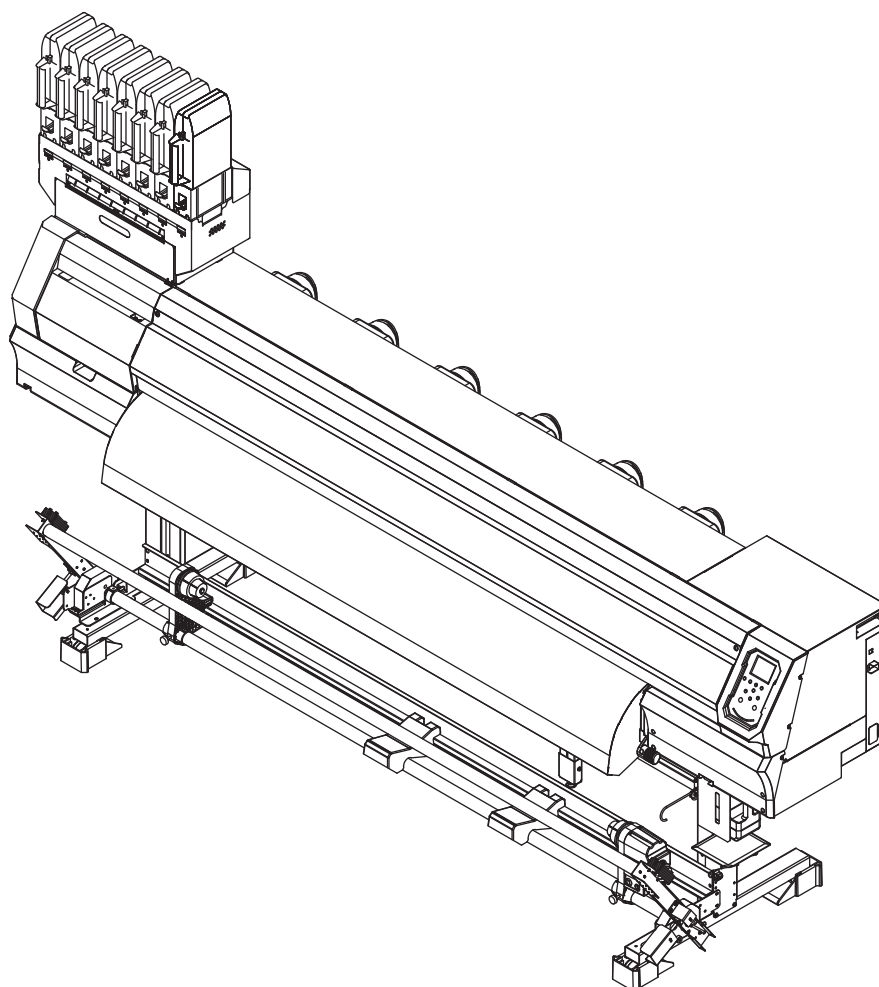

You can also download the latest manual from our website.

**MIMAKI ENGINEERING CO., LTD.**

URL: <https://mimaki.com/>

D202869-17  
Original instructions

# TABLE OF CONTENTS

---

Foreword .....	v
DISCLAIMER OF WARRANTY .....	v
Requests .....	v
FCC Statement (USA) .....	v
Interference to televisions and radios .....	v
Safety Precautions .....	vi
Symbols .....	vi
Safety interlock .....	viii
Warning labels .....	ix

## Chapter 1 Before Use

Moving This Machine .....	1-2
Where to Install This Machine .....	1-2
Working Environmental Temperature.....	1-2
Moving This Machine .....	1-2
Names of Parts and Functions .....	1-4
Front Side of the Machine .....	1-4
Rear Side and Right Side of the Machine .....	1-5
Operation Panel .....	1-6
Media sensor.....	1-8
Carriage.....	1-8
Cutter blade and slot for cutting .....	1-8
Capping station .....	1-8
Pinch rollers and Feed rollers.....	1-8
Connecting Cables .....	1-9
Connecting USB2.0 Interface Cable .....	1-9
Connecting the LAN cable.....	1-9
Connecting the power cable.....	1-10
About Ink .....	1-11
About usable ink.....	1-11
Setting Ink .....	1-11
Caution in handling of ink packs.....	1-13
Media .....	1-14
Usable sizes of media .....	1-14
Caution in handling of medias .....	1-14
Menu mode .....	1-15

## Chapter 2 Basic Operations

Workflow .....	2-2
Turning the Power ON/OFF .....	2-3
Turning the Power ON.....	2-3

Turning the Power OFF .....	2-3
Setting a Media .....	2-4
Adjusting the Head Height.....	2-4
Setting a roll media.....	2-5
Using the tension bar to set the roll media .....	2-8
Take-up device.....	2-10
Setting leaf media.....	2-14
Changing the printing origin .....	2-15
Preparing for the Heaters .....	2-16
Changing the Temperature Settings for the Heaters.....	2-16
Test Printing .....	2-16
Test Printing .....	2-16
Head Cleaning .....	2-17
About head cleaning.....	2-17
Perform head cleaning depending on the test printing result .....	2-17
Setting of Media Correction .....	2-18
Setting of Media Correction.....	2-18
If the Positions of Dots Shift... ..	2-18
Printing Data .....	2-19
Starting a Printing Operation .....	2-19
Stopping a Printing Operation .....	2-19
Deleting Received Data (Data Clear) .....	2-19
Behavior after printing has been completed .....	2-19
Cutting a media .....	2-20

## Chapter 3 Setup

About SETUP MENU .....	3-2
SETUP MENU table .....	3-3
Register the optimal print conditions to match the use.....	3-4
Setting of Media Correction.....	3-5
If the Positions of Dots Shift... ..	3-6
Setting the HEATER.....	3-6
Setting the Optional heater.....	3-7
Setting of Logical Seek.....	3-7
Setting of Overprint .....	3-8
Setting of Drying Time .....	3-8
Setting of Left and Right Margins .....	3-8
Setting of Refresh.....	3-9
Setting of Vacuum Fan .....	3-9
Setting of Feed Speed.....	3-9
Setting of Feed Quality .....	3-9
Setting of MAPS4 .....	3-10
Setting Auto Cleaning.....	3-11
Setting Interval wiping .....	3-11
Setting External heater .....	3-12
Setting Pre-feed .....	3-12
About MACHINE SETUP MENU .....	3-13
MACHINE SETUP MENU table .....	3-14
Setting a AUTO Power-off.....	3-16
Setting Take-up unit .....	3-16

Setting Top Blower .....	3-16
Setting the Display of Media Residual.....	3-17
Setting the PG Drop Adjust .....	3-17
Setting the Media Detection .....	3-17
Setting the Drying Feed.....	3-18
Setting a LANGUAGE .....	3-18
Setting Time .....	3-18
Setting Unit (Temperature/ Length).....	3-18
Setting a KEY BUZZER.....	3-19
Setting the VIEW FEED .....	3-19
Setting the amount of blank space between printed lines .....	3-19
Setting the SPACE FEED MODE.....	3-19
Set the network .....	3-20
Setting event mail function .....	3-20
Initializing the Settings.....	3-24
About NOZZLE CHECK MENU .....	3-25
INFORMATION MENU table.....	3-25
Printing Check Flow .....	3-26
Printing Operations at “Nozzle Missing” Judgment and Error Occurrence 3-26	
Setting the Printing Check.....	3-27
Setting the NOZZLE RECOVERY .....	3-27
Setting the Judgment Condition .....	3-27
About INFORMATION MENU .....	3-28
INFORMATION MENU table.....	3-28
Displaying the Information.....	3-29

## Chapter 4 Maintenance

Maintenance .....	4-2
Precautions for Maintenance.....	4-2
About Cleaning Solution .....	4-2
Cleaning the Exterior Surfaces.....	4-2
Cleaning the Platen .....	4-2
Cleaning the Media Sensor .....	4-3
Cleaning the Media Press .....	4-3
About MAINTENANCE MENU .....	4-4
MAINTENANCE MENUs at-a-glance.....	4-5
Maintaining the Capping Station .....	4-6
Cleaning the Wiper and Cap .....	4-6
Washing the Head Nozzle.....	4-7
Washing the Ink Discharge Passage .....	4-9
When the Machine Is Not Used for a Long Time .....	4-10
Cleaning the Ink Head and the Area around It .....	4-12
Nozzle Recovery Function .....	4-13
Reset the set value.....	4-14
Check the condition for which nozzle recovery cannot be performed .....	4-14
Enabling or disabling nozzle recovery during a test print.....	4-14
Automatic Maintenance Function .....	4-15
Setting the Refreshing Intervals .....	4-15

Setting the Tube Wash Intervals .....	4-15
Setting the Cleaning Intervals and Type .....	4-15
Suspend the nozzle cleaning .....	4-16
Fill up Ink .....	4-16
Replacing consumables .....	4-16
Replacing the wiper .....	4-16
If a Waste Ink Tank Confirmation Message Appears .....	4-17
Replace the waste ink tank with another .....	4-18
Replacing the Cutter Blade .....	4-19
Replacing the Spout Rubber .....	4-20
Male Connector Absorbent for MBIS .....	4-21

## **Chapter 5**

### **Troubleshooting**

Troubleshooting .....	5-2
Power does not turn on .....	5-2
The machine does not start printing .....	5-2
Media get jammed / media is soiled .....	5-2
The heater's temperature will not rise to the set level .....	5-3
Image quality is poor .....	5-3
Nozzle is clogged .....	5-3
Ink IC warning appears .....	5-3
When the ink leakage occurs .....	5-4
Warning / Error Messages .....	5-5
Warning messages .....	5-5
Error messages .....	5-8

## **Chapter 6**

### **Appendix**

Specifications .....	6-2
Machine specifications .....	6-2
Ink specifications .....	6-3
Setting orders depending on ink type .....	6-4
Setting orders of ink cartridges .....	6-4
Sheet for inquiry .....	6-5

## Foreword

Congratulations on your purchase of MIMAKI color ink jet printer "TS300P-1800" .

"TS300P-1800" is a color inkjet printer that can print on 1.8m-width media with sublimation dye ink (4-color, 6-color, 7-color and 8-color).

### DISCLAIMER OF WARRANTY

THIS LIMITED WARRANTY OF MIMAKI SHALL BE THE SOLE AND EXCLUSIVE WARRANTY AND IS IN LIEU OF ALL OTHER WARRANTIES, EXPRESS OR IMPLIED, INCLUDING, BUT NOT LIMITED TO, ANY IMPLIED WARRANTY OF MERCHANTABILITY OR FITNESS, AND MIMAKI NEITHER ASSUMES NOR AUTHORIZES DEALER TO ASSUME FOR IT ANY OTHER OBLIGATION OR LIABILITY OR MAKE ANY OTHER WARRANTY OR MAKE ANY OTHER WARRANTY IN CONNECTION WITH ANY PRODUCT WITHOUT MIMAKI'S PRIOR WRITTEN CONSENT. IN NO EVENT SHALL MIMAKI BE LIABLE FOR SPECIAL, INCIDENTAL OR CONSEQUENTIAL DAMAGES OR FOR LOSS OF PROFITS OF DEALER OR CUSTOMERS OF ANY PRODUCT.

### Requests

- This Operation Manual describes the operation and maintenance of Model "Color Ink Jet Printer TS300P-1800" (hereinafter referred to as the machine).
- Please read and fully understand this Operation Manual before putting the machine into service. It is also necessary to keep this Operation Manual on hand.
- Make arrangements to deliver this Operation Manual to the person in charge of the operation of this machine.
- This Operation Manual has been carefully prepared for your easy understanding, however, please do not hesitate to contact your local distributor, our sales office, or service center.
- Description contained in this Operation Manual are subject to change without notice for improvement.
- In the case where this Operation Manual should be illegible due to destruction or breakage, contact our sales office.
- You can also download the latest operation manual from our website.

### FCC Statement (USA)

This equipment has been tested and found to comply with the limits for a Class A digital device, pursuant to Part 15 of the FCC Rules. These limits are designed to provide reasonable protection against harmful interference when the equipment is operated in a commercial environment. This equipment generates, uses and can radiate radio frequency energy and, if not installed and used in accordance with the operation manual, may cause harmful interference to radio communications.

Operation of this equipment in a residential area is likely to cause harmful interference in which cause the user will be required to correct the interference at his own expense.

To prevent this, use of MIMAKI-recommended cable is essential for the connection of this printer.



- In the case where MIMAKI-recommended cable is not used for connection of this machine, limits provided by FCC rules can be exceeded. To prevent this, use of MIMAKI-recommended cable is essential for the connection of this machine.

### Interference to televisions and radios

The product described in this manual generates low radio waves while it is in operation. The product can interfere with radios and televisions if set up or commissioned under improper conditions. The product is not guaranteed against any damage to specific-purpose radios and televisions.

The product's interference with your radio or television will be checked by turning on/off the power switch of the product.

In the event that the product is the cause of interference, try to eliminate it by taking one of the following corrective measures or taking some of them in combination.

- Change the direction of the receiving antenna or the feeder of your radio/television.
- Move the receiver away from the product.
- Plug the power cord of this machine into an outlet which is isolated from power circuits connected to the television set or radio.

Reproduction of this manual is strictly prohibited.  
All Rights Reserved. Copyright  
© 2015 MIMAKI ENGINEERING Co., Ltd.











# Safety Precautions

## Symbols



Symbols are used in this Operation Manual for safe operation and for prevention of damage to the machine. The indicated sign is different depending on the content of caution.



Symbols and their meanings are given below. Please follow these instructions as you read this manual.

## Examples



Explanation	
	Failure to observe the instructions given with this symbol can result in death or serious injuries to personnel. Be sure to read it carefully and use it properly.
	Failure to observe the instructions given with this symbol can result in injuries to personnel or damage to property.
	Important notes in use of this machine are given with this symbol. Understand the notes thoroughly to operate the machine properly.
	Useful information is given with this symbol. Refer to the information to operate the machine properly.
	Indicates the reference page for related contents.
	The symbol "  " indicates that the instructions must be observed as strictly as the CAUTION instructions (including DANGER and WARNING instructions). A sign representing a precaution (the sign shown at left warns of hazardous voltage) is shown in the triangle.
	The symbol "  " indicates that the action shown is prohibited. A sign representing a prohibited action (the sign shown at left prohibits disassembly) is shown in or around the circle.
	The symbol "  " indicates that the action shown must be taken without fail or the instructions must be observed without fail. A sign representing a particular instruction (the sign shown at left instructs to unplug the cable from the wall outlet) is shown in the circle.

## Warning for Use

 <b>WARNING</b>	
	<ul style="list-style-type: none"> <li>The set of power cables provided with this machine is for use with this machine only, and cannot be used with other electrical devices. Do not use any power cables other than the ones provided with the machine. Failure to observe those instructions may result in fire or electric shocks.</li> <li>Take care not to damage, break or work upon the power cable. If a heavy material is placed on the power cable, or if it is heated or pulled, the power cable can break, thus resulting in fire or electric shocks.</li> </ul>

 <b>WARNING</b>	
	<ul style="list-style-type: none"> <li>Do not use this machine in an environment where humidity is high or the machine may get wet. Using the machine under such environment may result in fire or electric shock, or cause malfunction.</li> <li>Use of the machine under an abnormal condition where it produces smoke or strange smell can result in fire or electric shocks. If such an abnormality is found, be sure to turn off the power switch immediately and unplug the cable from the wall outlet. Check first that the machine no longer produces smoke, and then contact your distributor or a sales office of MIMAKI for repair.</li> <li>Never repair your machine by yourself since it is very dangerous for you to do so.</li> <li>Never disassemble or remodel the main unit of the machine or the ink cartridge. Disassembly or remodeling can result in an electric shock or breakdown of the machine.</li> <li>Take care that no dust or dirt sticks to Media Transfer Surface heaters. Dust and dirt sticking heaters can cause fire.</li> <li>Do not use extension cords. Doing so may result in fire or electric shocks.</li> <li>Keep the power plug prong clear of any foreign object such as a piece of metal. Failure to do so may result in a fire or electric shocks.</li> <li>Do not plug too many leads into a single socket. Doing so may result in fire or electric shocks.</li> <li>Do not use the machine if the power cord or plug is damaged. Using the machine with damaged power cord may result in fire or electric shocks. Contact your service representative for replacement cord.</li> <li>Do not handle the power plug with wet hands. Doing so may result in electric shocks.</li> <li>In case of ink leakage, please turn off the main power, unplug the power cable and contact your local distributor, our sales office, or service center.</li> <li>Grasp by holding the plug itself when removing the power plug from wall outlet, and never hold by the cord. Holding and pulling the cord may damage the cord, leading to fire or electric shocks.</li> </ul>
	<p><b>Hazardous Moving Parts</b></p> <ul style="list-style-type: none"> <li>Keep Fingers and Other Body Parts Away</li> <li>If a foreign object such as a small piece of metal or a liquid such as water gets inside the machine, turn off the machine and unplug the power cord immediately, then consult your service representative. Continuing to use the machine without proper maintenance or repair may result in fire or electric shocks.</li> </ul>

## Precautions in Use

 <b>CAUTION</b>	
<b>Power supply</b>	
	<ul style="list-style-type: none"> <li>Leave the breaker turned ON.</li> <li>Do not turn off the main power switch on the right side of this machine.</li> </ul>
<b>Heater</b>	
	<ul style="list-style-type: none"> <li>Do not spill liquid on the Media Transfer Surface as this may cause failure of the heater or firing.</li> <li>Do not touch Media Transfer Surface heaters with bare hand while it is hot; otherwise, you can get burned.</li> </ul>

**CAUTION**

**Handling of ink packs**



- Keep ink away from an open flame. Also keep the room well ventilated when you use or handle ink.
- If you get ink in your eyes, immediately wash your eyes with a lot of clean water for at least 15 minutes. In doing so, also wash eyes to rinse ink away completely. Then, consult a doctor as soon as possible.
- Before using ink and cleaning solution, be sure to read the Safety Data Sheet (SDS).
- If anyone drinks ink by mistake, keep him or her quiet and see a doctor immediately. Do not allow him or her to swallow the vomit.  
Then contact the emergency number written in SDS.
- If you inhale a great deal of vapor and feel ill, immediately move to a location with plenty of fresh air, and keep yourself warm and quiet. Consult a doctor as soon as possible.
- Store ink packs in a place that is out of the reach of children.
- If the ink adheres to your skin, use a large amount of water and soap or special detergent for skin to remove the ink.
- When you removed the ink pack from the seat before it ends, wipe ink adhering to inside of the connector part of the ink pack with a cotton swab etc. If ink adhering to inside of the connector part may dry out, it may cause ink leakage when using it again.

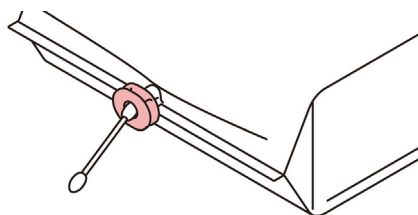

- When removing eco case from the seat, be sure to wear safety glasses etc. Ink may spatter and get in your eyes. Do not pull out and insert the middle cartridge again as much as possible.

**Handling of the power cable**



- Connect to a socket-outlet with determinate polarity.
- For PLUGGABLE EQUIPMENT, the socket-outlet shall be installed near the equipment and shall be easily accessible.
- Unplug the cord from the wall outlet and remove dust from the power plug periodically, at least once a year. Failure to do so may result in fire or electric shocks.
- Do not use the machine unless it is connected to a power supply that satisfies the displayed voltage condition.
- Check the voltage of the wall outlet and the capacity of the circuit breaker before you plug the power cords. Plug each power cord to different outlet that has independent circuit breaker. If you plug more than one power cord to wall outlets that share the same circuit breaker, the power may be cut off by the breaker.

**Note on maintenance**



- When handling ink and cleaning solution, pay close attention to ventilation and be sure to wear the included safety glasses and gloves.
- Pay close attention to ventilation and be sure to wear the included safety glasses and gloves.
- The gloves supplied with the machine are disposable. When all the gloves are expended, purchase an equivalent product on the market.



**CAUTION**



- Do not touch the sharp edge of the blade when replacing the cutter. Touching the sharp edge may result in injury.

**Notes When Handling this machine**



- Use the equipment in a well-ventilated or not-airtight room.
- Ventilate the room sufficiently before using the equipment.
- Do not place the equipment in a humid or dusty place. Otherwise, there is a risk of fire or electrical shock.
- Do not place the equipment in an unstable place such as on a shaky table and on a tilted surface. The equipment may fall over or drop and cause injury.
- The equipment is provided with a built-in media cutter. To replace or feed a printing medium, or to remove a jammed printing medium, do not touch any area other than those specified in this document. Otherwise, there is a risk of injury.
- To replace a printing media, be careful not to pinch your fingers or get injured.
- Do not leave the ink slot empty for a long time. Leaving it empty may dry the slot and solidify the ink in the machine, then the machine will become unable to supply ink.
- If ink packs are not set in the ink slot, an error message will display on the printer to set ink packs. Set the same colored ink cartridge as the ink used before.
- Consult with the service shop about cleaning inside the equipment.  
Leaving the equipment with dust inside without cleaning for a long time may cause a fire or device failure. Consult with the distributor or service shop for the cost of cleaning inside the equipment.
- To move the equipment, contact the nearest service shop.

**CAUTIONS and NOTES**

**Warning**

**Disposition of this machine**

- Consult your sales or service representative for proper disposal of this machine. Otherwise, commission an industrial waste disposal company.

**Protection of media from dust**

- Store media in a bag. Wiping off dust accumulated on media will adversely affect the media due to static electricity.
- When leaving the workshop after the working hours, do not leave any media on the roll hanger. If any media is left on the roll hanger, it can get dusty.

**Periodic replacement parts**

- Some parts of this machine must be replaced with a new one periodically by service personnel. Be sure to make a contract with your distributor or dealer for After sale service to ensure a long life of your machine.



**Warning**

**Handling of media**

- Use media recommended by MIMAKI to ensure reliable, high-quality printing.
- Set the heater temperature to meet the characteristics of the media. (Model with a built-in heater)  
Set the temperature of the Post-heater according to the type and characteristics of the media used. Automatic temperature setting can be made on the operation panel by setting the profile on the dedicated RIP. For setting on the RIP, refer to the instruction manual for your RIP.
- Pay attention to the expansion and contraction of the media.  
Do not use media immediately after unpacking. The media can be affected by the room temperature and humidity, and thus it may expand and contract. The media have to be left in the atmosphere in which they are to be used for 30 minutes or more after unpacked.
- Do not use curled media.  
The use of curled media can not only cause a media jam but also affect print quality.  
Straighten the sheet of media, if significantly curled, before using it for printing. If a regular-sized coated sheet of media is rolled and stored, the coated side has to face outside.

**Handling of ink packs**



- The safety evaluation of this machine assumes that the ink recommended by this company is used. For safe usage of this machine, use the ink recommended by this company
- Never refill the ink pack with ink. Refilled ink pack can cause a trouble. Remember that MIMAKI assumes no responsibility for any damage caused by the use of the ink pack replenished with ink.
- If the ink pack is moved from a cold place to a warm place, leave it in the room temperature for three hours or more before using it.
- Open the ink pack just before installing it in the machine. If it is opened and left for an extended period of time, normal printing performance of the machine may not be ensured.
- Make sure to store ink packs in a cool and dark place.
- Store ink packs and waste ink bottle in a place that is out of the reach of children.
- Be sure to thoroughly consume the ink in the ink pack, once it is opened, within three months. If an extended period of time has passed away after opening the cartridge tank, printing quality would be poor.
- Neither pound the cartridge nor shake it violently, as doing so can cause leakage of ink.
- Consult your sales or service representative for proper disposal of ink pack, ink pack, and waste ink.  
When you dispose them by yourself, follow the regulations stipulated by the industrial waste disposer or the country or region you live in.
- Do not leave the media with the heater ON for a long time.

**Notes on maintenance**

- It is strongly recommended to use the machine in a room that is not dusty.
- Keep the front cover closed even when the machine is not printing. If not, dust can accumulate on the nozzles in the heads.
- Dust in the heads can also cause drops of ink to fall suddenly down on the media during printing. In such a case, be sure to clean up the heads.
- When cleaning the ink-station or the heads, be sure to wear the included safety glasses and gloves.
- Perform wiping (removal of dust and paper powder) of the capping station and wiper frequently.

**Cautions on Installation**

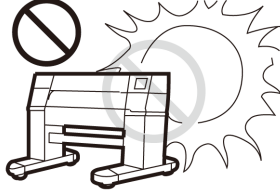
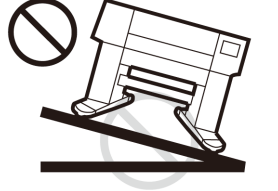
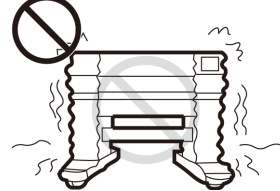
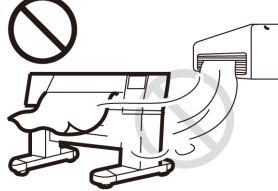
**CAUTION**

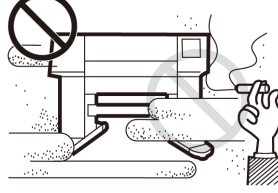
<b>A place exposed to direct sunlight</b>	<b>On an inclined surface</b>
	
<b>A place that vibrates</b>	<b>A place exposed to direct air flow from an air conditioner or the like.</b>
	
<b>A place where temperature or humidity varies significantly</b>	<b>Around a place where fire is used</b>
<p> Use the machine under the following environmental conditions:</p> <p>• Operating environment: 20 to 30 °C (68 to 86 °F) 35 to 65 % (Rh)</p>	

**Safety interlock**



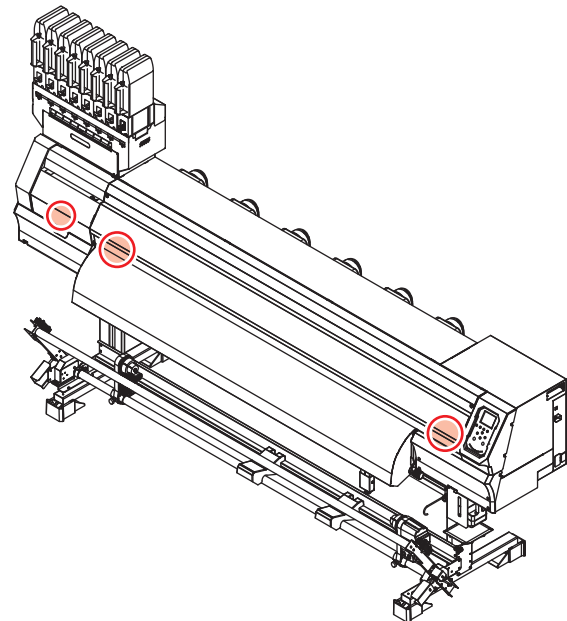



This machine is equipped with interlocks to terminate the operation for your safety when the cover opens during printing etc. (red circle parts in the figure below).

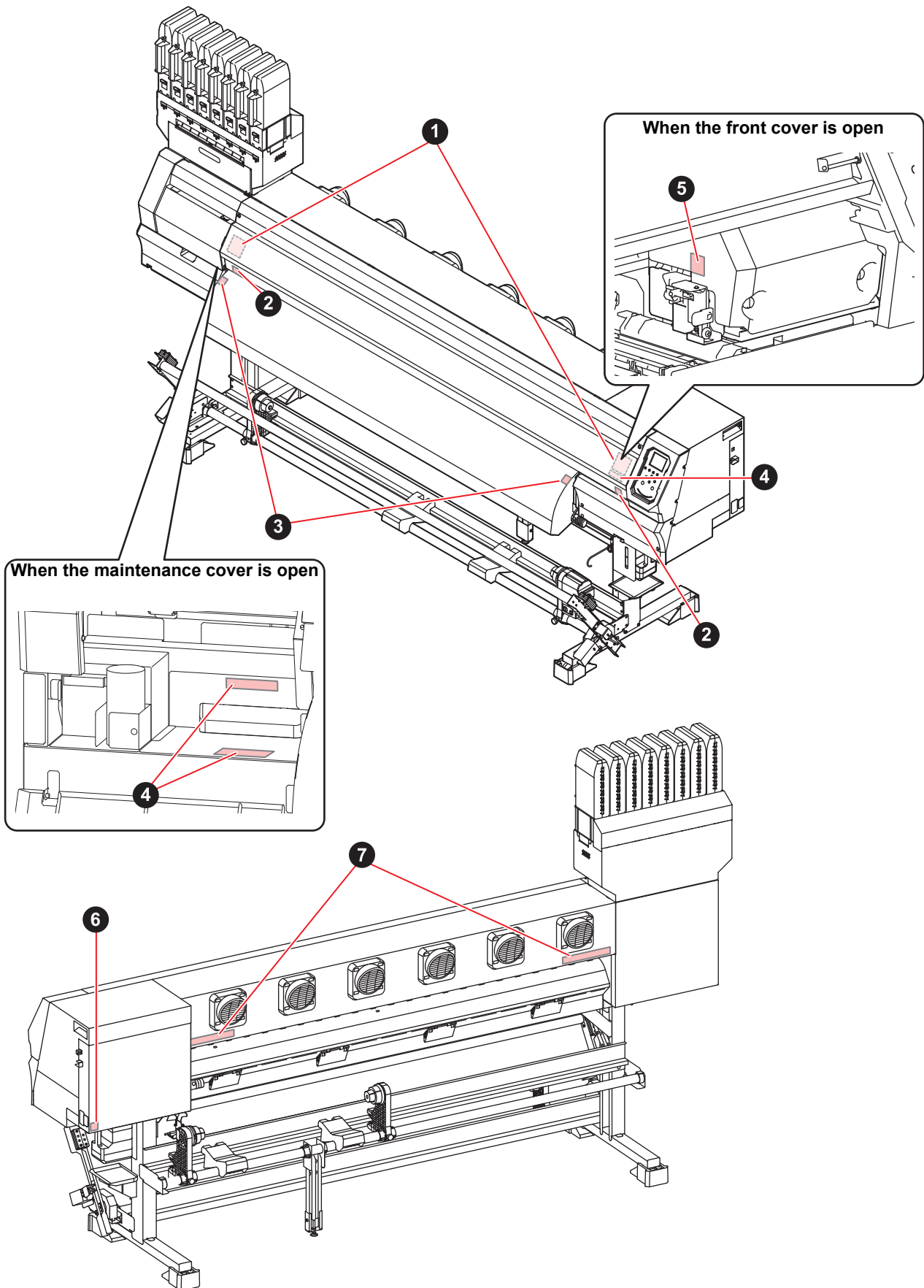

# Warning labels

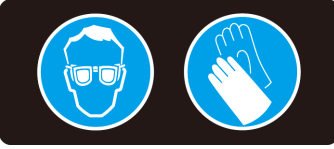
Warning labels are stuck on the machine. Be sure to fully understand the warning given on the labels. If a warning label is illegible due to stains or has come off, purchase a new one from a distributor or our sales office.



No.	Reorder	Label										
1	M910931	 <p><b>CAUTION</b> <b>ATTENTION</b></p> <p><b>COVER HAZARD</b> May result in severe injury. When open and close the cover, hold a cover until the end.</p> <p><b>COUVERCLE-DANGER</b> Peut entraîner de graves blessures. Lors de l'ouverture ou de la fermeture du couvercle, tenir le couvercle jusqu'à la fin.</p> <p>カバー急落下あり 指を挟まれると、ケガや骨折の恐れあり。 カバーの開閉は、最後まで手を添えて行ってください。</p> <p>M910931</p>										
2	M907833											
3	M903239											
4	M903330											
5	M903405											
6	M907935											
7	M905811	 <table border="1"> <thead> <tr> <th>警告</th> <th>警告</th> <th>WARNING</th> <th>WAARSCHUWING</th> <th>AVERTISSEMENT</th> </tr> </thead> <tbody> <tr> <td>手指和身体请勿靠近运转部位，以免造成危险</td> <td>危険な稼働部 指や体を近づけないように</td> <td>-HAZARDOUS MOVING PARTS- Keep fingers and other body parts away.</td> <td>GEFÄHRLICHE BEWEGLICHE TEILE Finger und andere Körperteile fernhalten.</td> <td>PIECES MOBILES DANGEREUSES Doigts et autres parties du corps sont hors de portée.</td> </tr> </tbody> </table>	警告	警告	WARNING	WAARSCHUWING	AVERTISSEMENT	手指和身体请勿靠近运转部位，以免造成危险	危険な稼働部 指や体を近づけないように	-HAZARDOUS MOVING PARTS- Keep fingers and other body parts away.	GEFÄHRLICHE BEWEGLICHE TEILE Finger und andere Körperteile fernhalten.	PIECES MOBILES DANGEREUSES Doigts et autres parties du corps sont hors de portée.
警告	警告	WARNING	WAARSCHUWING	AVERTISSEMENT								
手指和身体请勿靠近运转部位，以免造成危险	危険な稼働部 指や体を近づけないように	-HAZARDOUS MOVING PARTS- Keep fingers and other body parts away.	GEFÄHRLICHE BEWEGLICHE TEILE Finger und andere Körperteile fernhalten.	PIECES MOBILES DANGEREUSES Doigts et autres parties du corps sont hors de portée.								



# Chapter 1

## Before Use



### This chapter

describes the items required to understand before use, such as the name of each part of the machine or the installation procedures.

Moving This Machine .....	1-2	Connecting Cables .....	1-9
Where to Install This Machine .....	1-2	Connecting USB2.0 Interface Cable .....	1-9
Working Environmental Temperature .....	1-2	Connecting the LAN cable .....	1-9
Moving This Machine .....	1-2	Connecting the power cable .....	1-10
Names of Parts and Functions .....	1-4	About Ink .....	1-11
Front Side of the Machine .....	1-4	About usable ink .....	1-11
Rear Side and Right Side of the Machine ...	1-5	Setting Ink .....	1-11
Operation Panel .....	1-6	Caution in handling of ink packs .....	1-13
Media sensor .....	1-8	Media .....	1-14
Carriage .....	1-8	Usable sizes of media .....	1-14
Cutter blade and slot for cutting .....	1-8	Caution in handling of medias .....	1-14
Capping station .....	1-8	Menu mode .....	1-15
Pinch rollers and Feed rollers .....	1-8		

# Moving This Machine

## Where to Install This Machine

Secure a suitable installation space before assembling this machine.

The place of installation must have enough space for not only this machine itself, but also for the printing operation.

Model	Width	Depth	Height	Gross weight
TS300P-1800	3,200 mm (126.0 in)	850 mm (33.5 in)	1,857 mm (73.1 in)	213 kg (469.6 lb)

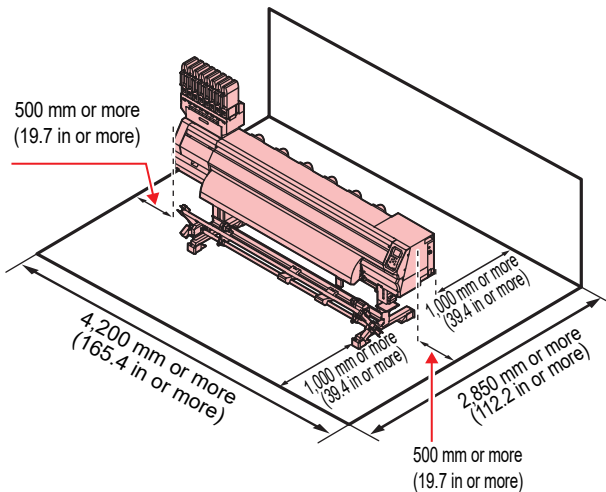

## Working Environmental Temperature

Use this machine in an environment of 20 to 30°C (68 to 86°F) to ensure reliable printing.

## Moving This Machine

Move this machine according to the following steps when this machine needs to be moved on the same step-free floor.



- When the machine is moved to any place other than on the same step-free floor, contact your distributor or our service office. If you move it by yourself, failure or damage may occur. Be sure to request your distributor or our service office to move this machine.



- When moving this machine, take care that it does not receive a significant impact.
- Be sure to lock the casters after moving of this machine.

### 1 Remove the caster blocks.

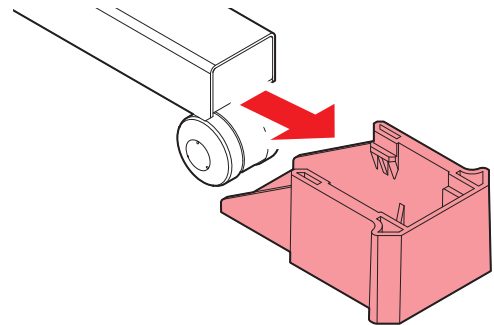

### 2 Raise the take-up legs.

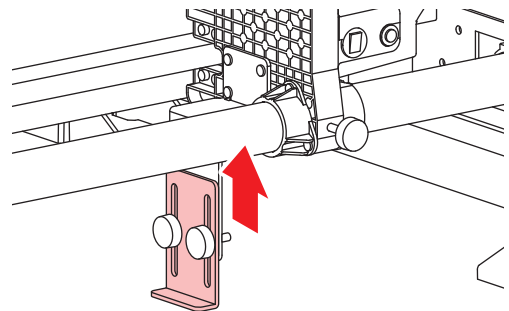

### 3 Raise the adjuster foot of the roll guide stay.

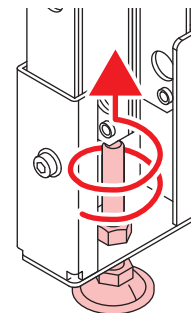

**4** Move this machine as shown in the figure.

- For safety, be sure to operate it with 4 people or more.
- Do not push the cover to move this machine since the cover may be broken.

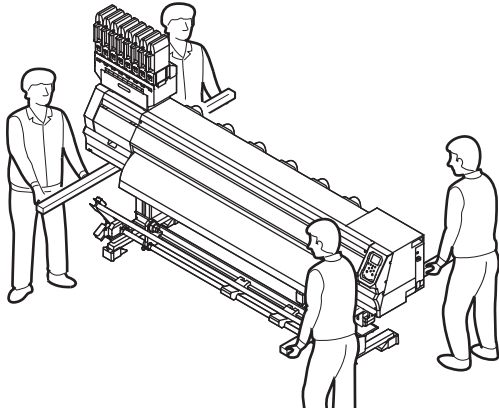
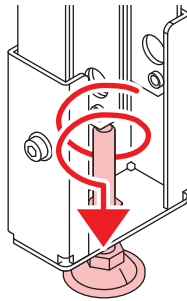
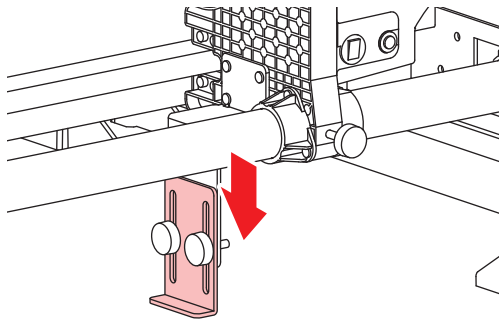
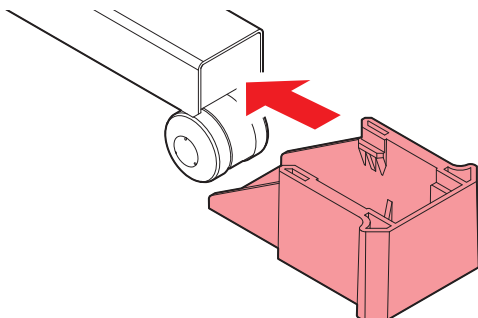
**5** Lower the adjuster foot of the roll guide stay.**6** Lower the take-up legs.**7** Reinstall the caster blocks.

# Names of Parts and Functions

## Front Side of the Machine

### Maintenance cover (upper)

Open the cover in maintenance.  
Even when the power switch is off, keep all covers closed.

### Ink cartridges

Each cartridge contains an ink of a particular color.

### Front cover

Open the cover in setting of medias, taking of measures against jamming of medias or in maintenance inside the station.  
Even when the power switch is off, keep this cover and the other covers closed.

### Clamp lever (front)

Moves the pinch rollers up and down to hold or release the media.

### Carriage

Move the print head unit from side to side.

### Operation panel

This panel has the operation keys required for operating the machine and the LCDs for displaying setting items, etc.

### CleaningSolutionCartridge slot

Insert the cleaning solution cartridge.

### Waste ink tank

Waste ink gathers in this tank.

### Stand

Supports the main body of the machine. It is provided with casters that are used to move this machine.

### Take-up device

Automatically winds up the roll media printed.

### Roll rests

Rests for placing the roll on when installing roll media.

### Take-up tension bar

It supports to adjust the tension to wind up roll media.

### Platen

The printed media is sent out, sliding on the platen.

### Maintenance cover (lower)

Open the cover in maintenance.  
Even when the power switch is off, keep all covers closed.

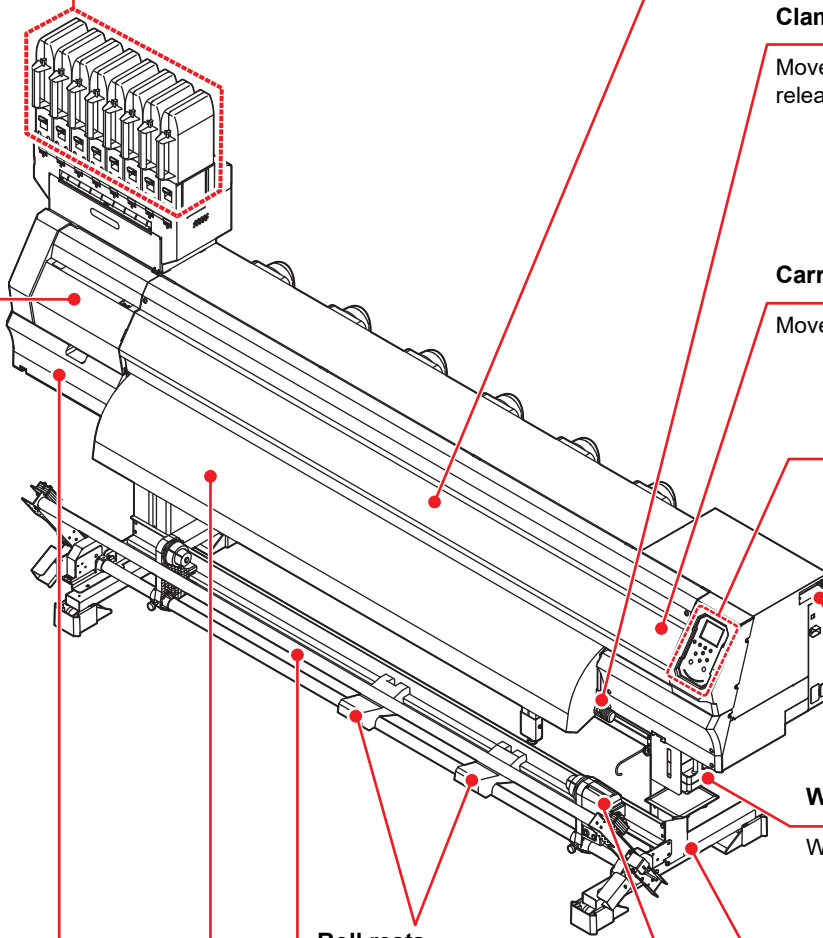



## Rear Side and Right Side of the Machine

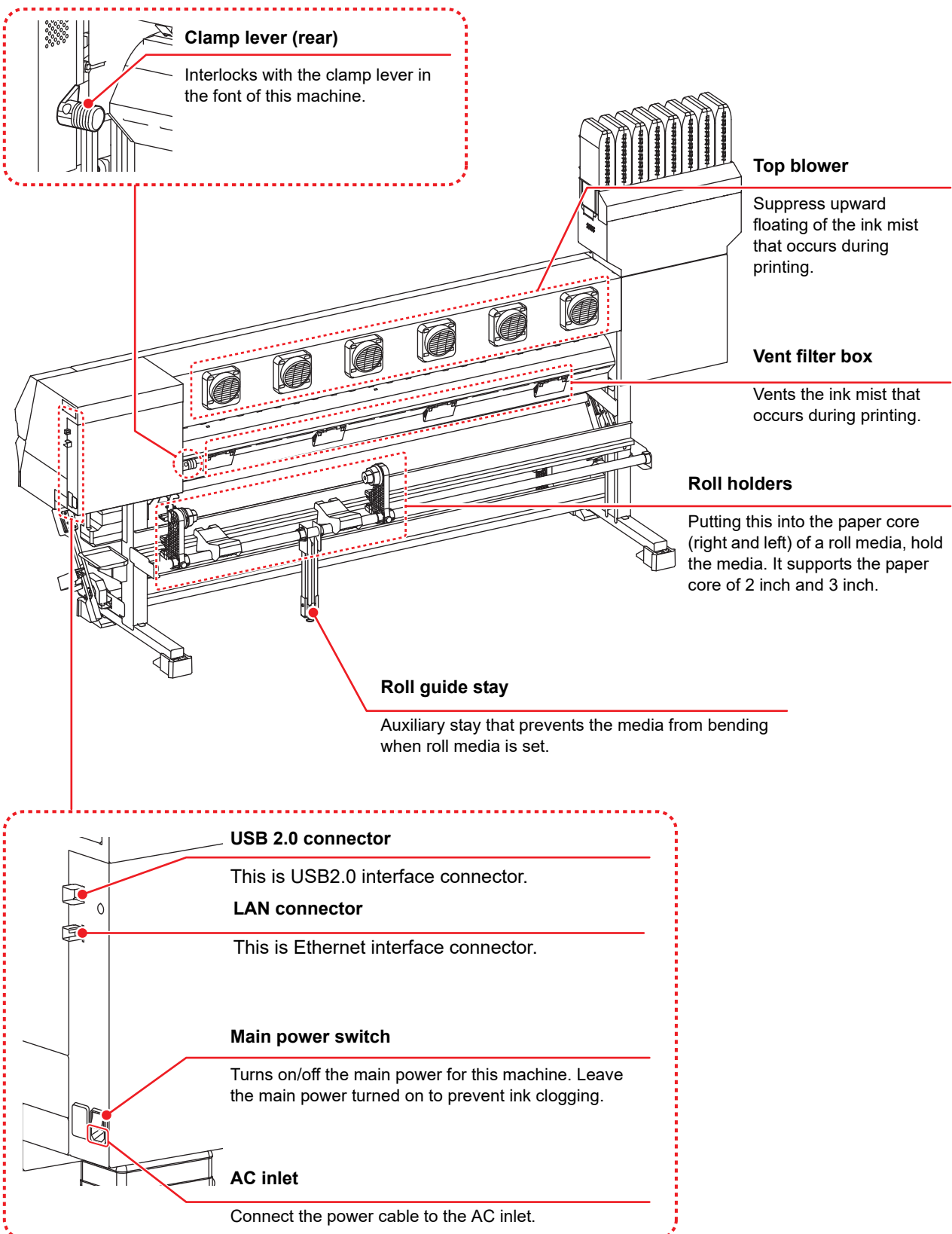

## Operation Panel

Use the operation panel to make settings for printing or operate this machine.

**SEL key**

Changes over the functions of the function keys ([FUNC1]–[FUNC3]).

**[FUNC1] / [FUNC2] / [FUNC3] key**

Press this to set various functions or to do test printing. The function keys' functions are changed each time [SEL] key is pressed.

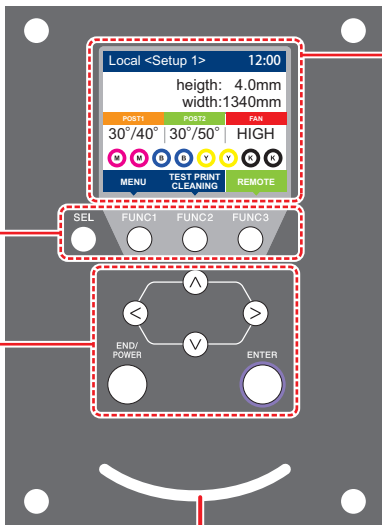

**Display**

Displays the following items:

- Printer status
- Set media width
- Heater temperature (current temperature/set temperature)
- Ink status <sup>\*1</sup>
- Functions assigned to [FUNC1] to [FUNC3] <sup>\*2</sup>

**JOG key**

Use these keys to shift the carriage or the media in [LOCAL]. Also use them to select an item of printing conditions.

**[END/POWER] key**

Cancels the last input value or returns the setting menu to the immediate higher level of the hierarchy. Also, press this to turn the power on or off. (Give it a long press to turn the power off.)

**[ENTER] key**

Registers the last input value as the setting value or goes to the immediate lower level of the hierarchy.

**Status indicator lamp**

Indicates the machine's status (printing, error occurred, etc).

Condition of Lamp	Condition of machine
OFF	Machine is in LOCAL mode, no print data has been received, and no errors have occurred.
Lit steady Light blue	Switched to REMOTE mode.
Flashing Light blue	Currently printing. In test printing: printing a pattern stored inside the machine.
Lit steady blue	Print data still remains in the machine.
Flashing red	Error has occurred.
Lit steady red	Error (SYSTEM HALT) has occurred.
Lit steady yellow	Firmware is being updated.



- The power switch under the operation panel lights in blue when the power is turned on, and off when the power switch is turned off. The ink clogging prevention function is periodically operated even when the power switch is OFF if the main power switch keeps being ON. (Auto maintenance function) P.1-5















### \*1 : Ink Status

Status of the ink cartridge (remaining ink/error, etc.) is displayed using icons. Each icon is described below.

Icon	Contents																		
	<p>The remaining amount of ink is displayed in 9 stages. The remaining amount decreases moving to the right.</p> <table border="1" style="width: 100%; text-align: center; border-collapse: collapse;"> <tr> <td></td> <td></td> <td></td> <td></td> <td></td> <td></td> <td></td> <td></td> <td></td> </tr> <tr> <td>ink full</td> <td>Approximately 1/8 consumed</td> <td>Approximately 1/4 consumed.</td> <td>Approximately 3/8 consumed.</td> <td>Approximately 1/2 consumed.</td> <td>Approximately 5/8 consumed.</td> <td>Approximately 3/4 consumed.</td> <td>Approximately 7/8 consumed.</td> <td>near end</td> </tr> </table>										ink full	Approximately 1/8 consumed	Approximately 1/4 consumed.	Approximately 3/8 consumed.	Approximately 1/2 consumed.	Approximately 5/8 consumed.	Approximately 3/4 consumed.	Approximately 7/8 consumed.	near end
ink full	Approximately 1/8 consumed	Approximately 1/4 consumed.	Approximately 3/8 consumed.	Approximately 1/2 consumed.	Approximately 5/8 consumed.	Approximately 3/4 consumed.	Approximately 7/8 consumed.	near end											
	Displayed at ink end (only when the 4-color ink set is used) and ink near end.																		
	Indicates that the cartridge cannot be used due to ink end or ink error (cartridge not attached, etc.).																		
	Indicates that ink has expired or that one month has passed after the expiration date. Please use quickly. Ink can no longer be used if two months have passed after the expiration date.																		

## \*2 : Functions assigned to [FUNC1] to [FUNC3]

Contents of functions assigned to [FUNC1] to [FUNC3] are described below.

Icon	Contents
	Displays "MENU" for setting functions.
	Displays maintenance functions such as test print, cleaning, etc.
	Shifts to REMOTE from LOCAL and starts printing.
	Displays adjustment functions such as FEED COMP, DROP.POScorrect, etc.
	Sets the heater temperature.
	Executes data clear.
	Suspends printing in REMOTE and shifts to LOCAL.
	Executes media cut.
	When there are multiple items on the MENU screen or other screens, it moves to the next page.
	When there are multiple items on the MENU screen or other screens, it moves to the previous page.
	Used for completing confirmation when warning message has been displayed and so on.
	Used for turning functions OFF or cancelling them, for example, when turning heater settings OFF and so on.
	Some kind of setting or function is assigned. Operate according to the description of each function.
	Switches between enable/disable when selecting multiple items, for example, when selecting target head for cleaning and so on.



- The color of icons changes according to the state of the printer.
  - When the icon is green : The printer is in REMOTE mode.
  - When the icon is dark blue : The printer is in LOCAL mode.
  - When the icon is yellow : A warning has been issued.
  - When the icon is red : An error has been issued.

## Media sensor

The media sensor detects the presence of the media and the media length.  
This machine has two media sensors on the platen (in the rear).

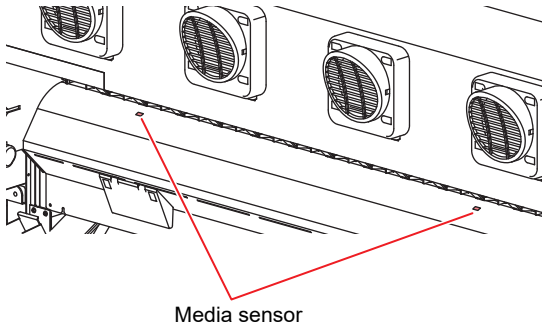

**Important!**

- When setting a media, be sure to cover the media sensors located on the rear of the platen. The media cannot be detected unless it is placed over the sensor.

## Carriage

The carriage is provided with the ink heads for printing, the "LED pointer" to be used for manually setting the width of the set media (☞ P.2-9), and the cutter unit for cutting off the sheet of media, etc.  
A lever is also provided to adjust the height of Head according to the thickness of media. (☞ P.2-4)

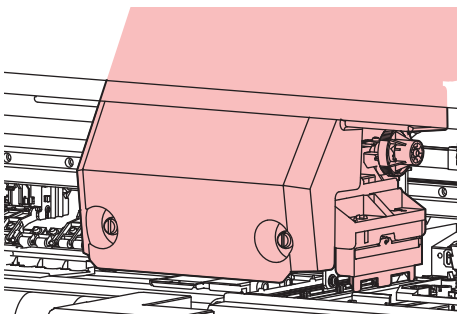

## Cutter blade and slot for cutting

The carriage is provided with a cutter unit for cutting off the media that has been printed on.  
The cutter cuts off the sheet of media along the slot for cutting on the platen.

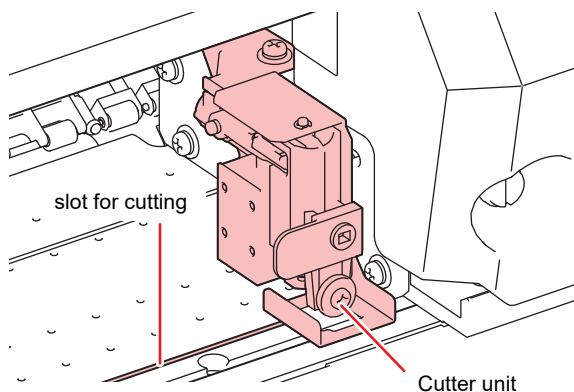

## Capping station

The capping station consists of the ink caps, the wiper for cleaning the heads, etc.  
The ink caps prevent the nozzles in the ink heads from drying up.  
The wiper cleans the nozzles in the heads.  
The wiper is consumable. If the wiper is deformed or the media is stained, replace the wiper with a new one.



- Be sure to wear the attached safety glasses in cleaning within the capping station to protect your eyes against ink. Otherwise, you may get ink in your eyes.

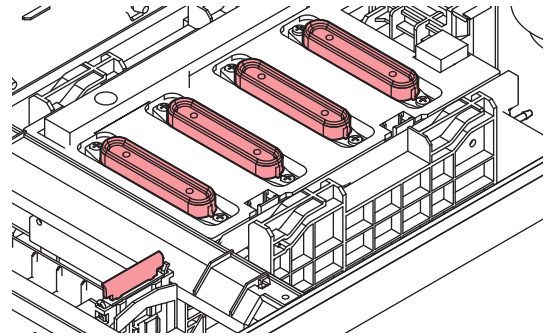

## Pinch rollers and Feed rollers

This machine retains the media with the pinch rollers and feed rollers. During printing operation, the feed rollers feed the media forward.

**Important!**

- Keep the pinch rollers lifted up when this machine is not in use. If the pinch rollers are left lowered for an extended period of time, they can be deformed and fail to securely retain the media.

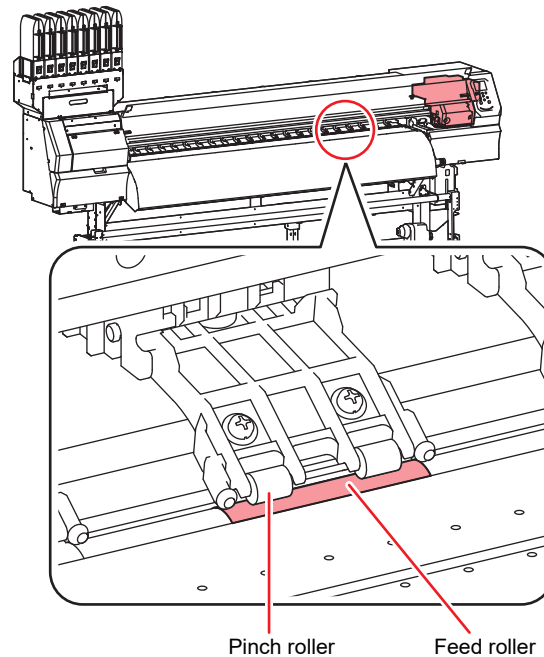

# Connecting Cables

## Connecting USB2.0 Interface Cable

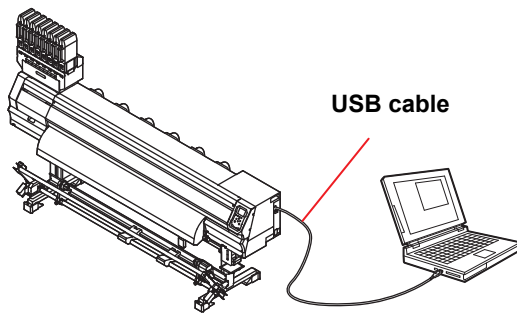

Connect the PC and this machine with the USB2.0 interface cable.



- Your RIP must be compatible with USB 2.0.
- Contact a RIP maker near your location or our office when the USB2.0 interface is not attached to the PC.

## Notes on USB 2.0 Interface



- Your RIP must be compatible with USB 2.0.

### ● When two or more TS300P machines are connected to one personal computer

When two or more TS300P machines are connected to one personal computer, the personal computer may not recognize all the TS300P machines normally. Reconnect the unrecognized TS300P machine to another USB port, if available, and check to see if it is recognized. If the TS300P machine is not recognized by the newly connected USB port, use USB 2.0 repeater cables available on the market.

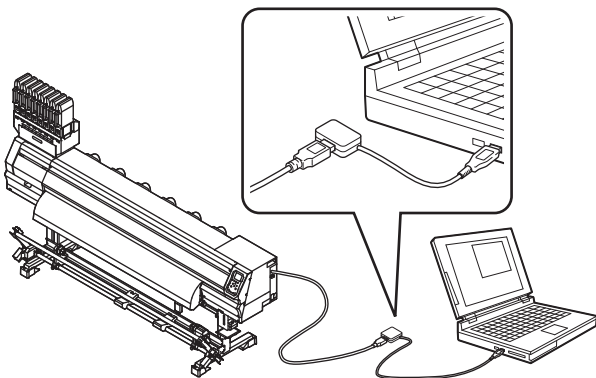

### ● Notes on peripheral devices in USB high speed mode

When a peripheral device (USB memory or USB HDD) to be operated in USB high speed mode is connected to the same personal computer that a TS300P machine is connected to, the USB device may not be recognized. When TS300P is connected to the personal computer to which an external HDD is connected via USB, the speed of data output to TS300P may drop. That can cause the head unit to stop temporarily at the right or left end during printing.

### ● Removing USB memory

If a USB memory module is inserted in the personal computer to which a TS300P machine is connected, click "Stop" in the "Safely Remove Hardware" window by following the instructions given there first and then remove the module.

Leaving a USB memory module inserted can cause [ERROR 10 COMMAND ERROR].

Copy the data onto the hard disk before outputting it for printing.

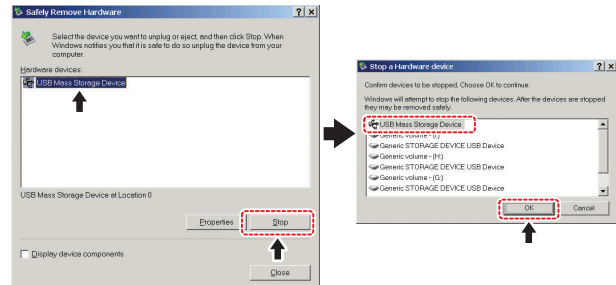

## Connecting the LAN cable

When connecting LAN cable, be sure to follow the note below:



- Surely insert LAN cable until clicking noise sounds.
- Do not plug in or unplug any cable during data transferring.

## Printing Via a Network

If printing via a network, you need to configure your network with the following environment.

If you configure it with an inappropriate environment, it could cause printing to stop.

- Use LAN cables that are category 6 or higher.
- Use a switching hub and PC that support 1000BASE-T.



- Set the PC sending the print data and the printer to the same network.
- You cannot connect via a router.

### ● If connecting directly to the printer

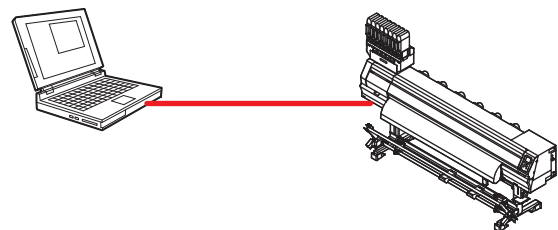

● If connecting via a switching hub

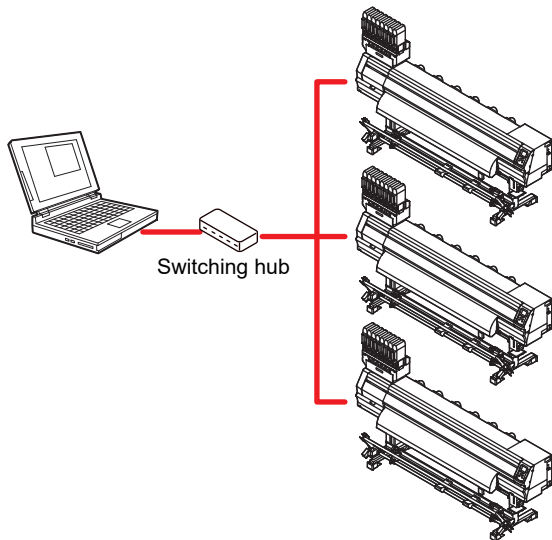

If the PC or device connected to the printer is not 1000BASE-T, you cannot perform printing. After connecting, check the following.

(1) Check the printer screen display.

- On the local screen or the media detection screen, press the [Enter] key several times to display the information screen.
- Check that "1000Mbps" is displayed for the LAN status item.

**Important!**

- If "100Mbps", "10Mbps", or "No connect" is displayed, you cannot print using the LAN.
- If "100Mbps" or "10Mbps" is displayed, you can use event mail (☞ Chapter3 "Setting event mail function").

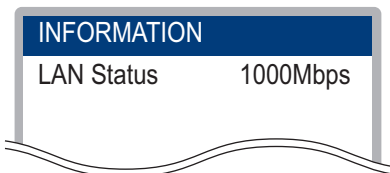

(2) Check the green light of the LAN connector.

- After turning on the machine, the lamp for the LAN connector will light up as follows.

Color	State	Condition
Green	Lighting	Connected with 1000BASE-T
	OFF	Connected without 1000BASE-T
Yellow	Lighting	Link-up
	Blinking	Receiving data
	OFF	Link-down

**Important!**

- If the yellow light only lights up, or is blinking, the status is not 1000Mbps. Check the specifications of the PC, device, and cables.

**Connecting the power cable**

**1** Insert the power cable into an inlet of the machine.

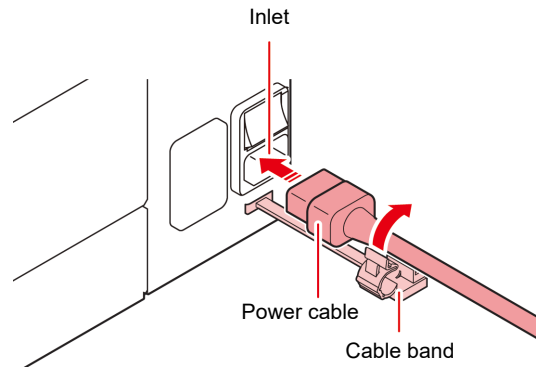

**2** Secure a cable band.

- Secure the cable with the cable band attached to this machine.

**3** Insert the power plug into a plug socket.

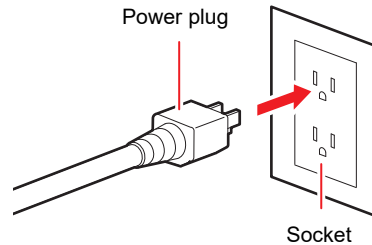

- Do not use any power cables other than the attached power cable.

**Important!**

- Be sure to connect the power cable to the outlet near this machine, and make sure that the power cable can be easily removed.
- Connect the power cable to the grounded outlet. Otherwise, it may result in fire or an electric shock.

# About Ink

## About usable ink

You can use aqueous sublimation dye ink (Sb410/Sb411) for this machine.



- For usable ink, refer to P.6-3 "Ink specifications" and P.6-4 "Setting orders of ink cartridges".

## Setting Ink

### 1

#### Take out the 2L ink pack.

- Take out the 2L ink pack and the ink IC chip from a small cardboard box.

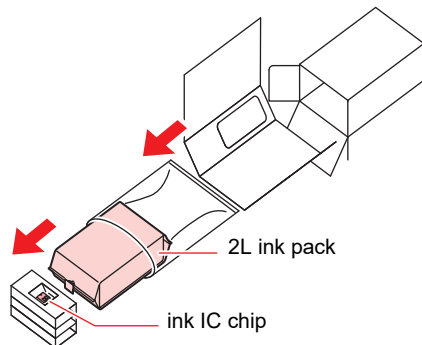

### 2

#### Mount the ink IC chip.

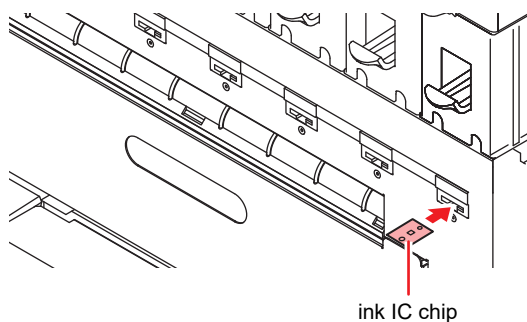

- Be careful of the ink IC chip direction. If it is set in the wrong direction, ink is not supplied properly.

Insert the chip facing the metal side to the left. Do not touch the metal part while inserting. (The ink IC chip may be damaged by static electricity.)

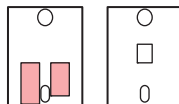

### 3

#### Put the 2L ink pack into the 2L eco case.

- Open the 2L eco case as shown on the right.

(1) While pressing the finger grip,

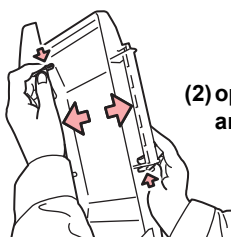

(2) open to right and left.

- Tear off the seal on the connector of the 2L ink pack.

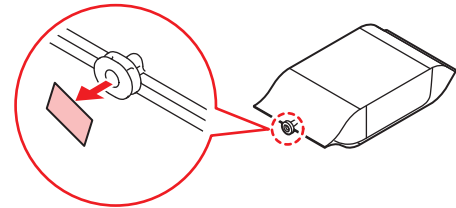

- Be careful of the ink IC chip direction. If it is set in the wrong direction, ink is not supplied properly.



OK

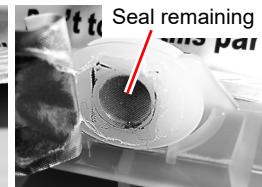

No Good

- Put the 2L ink pack facing the connector down, and close the 2L eco case.

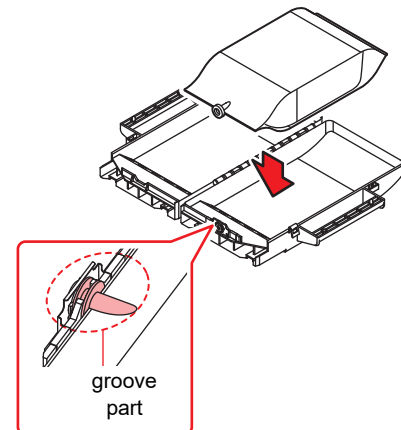

- When putting the 2L ink pack, shape the pack referring to the label in the 2L eco case. If unshaped, you may not use up the ink.
- Before closing the 2L eco case, make sure the connector of the ink pack is placed on the groove part of the 2L eco case. If it is not placed on the groove, it may not supply ink.

#### 4 Attach the 2L eco case to the base.

- Ink is supplied to the printer connecting to the 2L eco case.
- After 1 or 2 minutes, EMPTY lamp on the connected printer goes out.

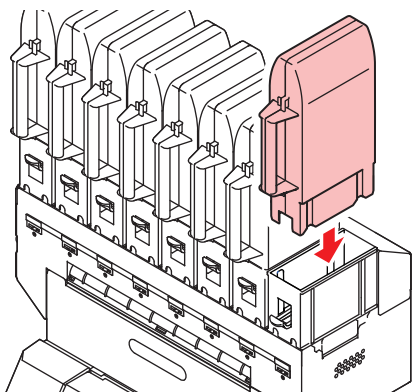

- Push the 2L eco case all the way in. If not, it may not supply ink.

### Replacing the 2L Ink Pack

Perform as follows when [INK END] or [INK NEAR END] is displayed on the display.



- When exchanging 2L ink pack, be sure to wear the included safety glasses and gloves. Ink may spatter and get in your eyes accidentally.



- Although approximately 10 cc of ink remains in the ink pack after use, the pack is filled so that the actual amount used is two liters.

#### ● When [INK END] is displayed

#### 1 Push the lever of the base down, and remove the 2L eco case.

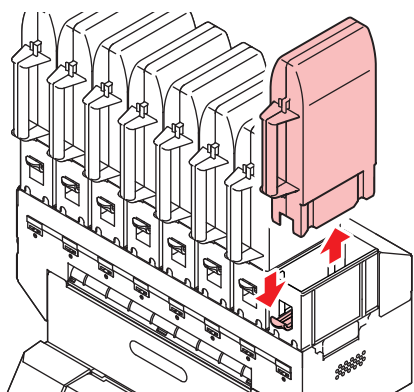

- When replacing the 2L ink pack, replace the male connector absorbent (attachment) periodically to prevent the stain in the base.
- Replace the absorbent every five to ten times of the 2L ink pack replacement.
- When replacing the absorbent, be sure to wear the included safety glasses and gloves.

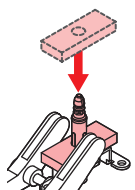

#### 2 Remove the ink IC chip.

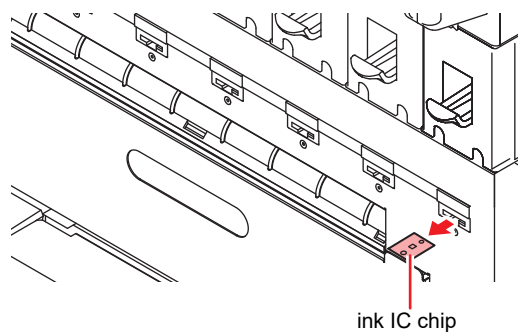

ink IC chip

#### 3 Open the 2L eco case, then replace the 2L ink pack.

- Keep the ink IC chip removed in the step 2 with used 2L ink packs. (Not to mix with an ink IC chip of a new ink pack)

#### 4 Mount the ink IC chip supplied with the replacement 2L ink pack.



- Be careful not to touch the metal part of the ink IC chip. There is the danger of damaging ink IC chip because of static electricity being generated.

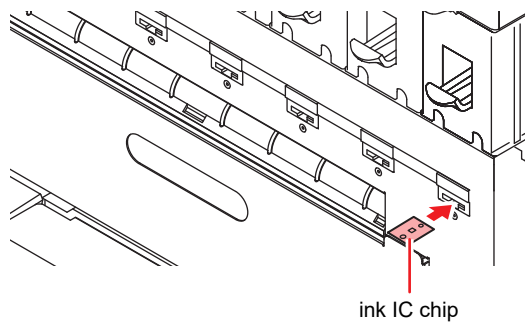

ink IC chip



- If removing an ink pack before it ends, follow the procedures below. Otherwise, you cannot accurately grasp the remaining amount of ink.
  - (1) Remove an ink pack from an eco case.
  - (2) Wipe ink adhering to inside of the connector part of the 2L ink pack with a cotton swab etc.

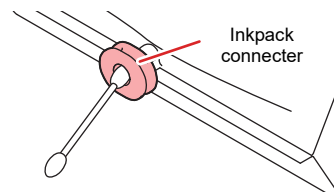

Inkpack connector

- (3) Remove the ink IC chip, and keep it with the ink pack.
- (4) If you use the ink pack again, set the pack, and mount the ink IC chip kept with the pack.

#### ● When [INK NEAR END] is displayed

There is a little of ink left. It is recommended to replace the ink pack soon since ink may become empty in printing while printing is continuously enabled.



- During [INK NEAR END] is displayed, Auto cleaning does not operate. (P.3-11)



## For Ink cartridge lamps

The condition of the ink cartridges set in the machine is confirmable with lamps located under the ink cartridges.

Ink cartridge lamps

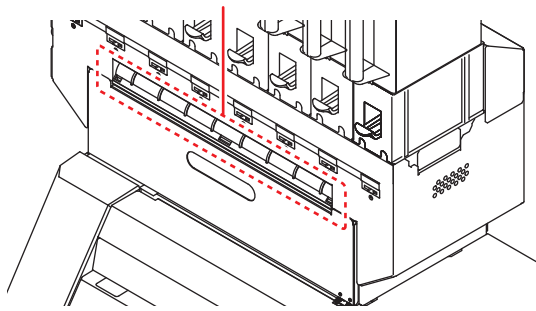

Condition of Lamp	Description
Lit to blue	No error (ink is being supplied)
OFF	No error
Lit or blinks to yellow	One of the following errors occurs. <ul style="list-style-type: none"> <li>• Ink near-end</li> <li>• Expiration of a term of ink validity (one month)</li> </ul>
Blinks to red	Expiration of a term of ink validity (two months)
Lit to red	One of the following errors occurs. <ul style="list-style-type: none"> <li>• Ink end</li> <li>• No ink IC chip inserted</li> <li>• Other ink errors (☞ P.5-7)</li> </ul>

## About ink expiration date

The ink pack has its expiration date.

When this expiration date is exceeded, a message is displayed in LOCAL and for the guidance message. (☞ P.5-5, P.5-7)

You can use the cartridge in two months after the expiration date indicated on it, however, you cannot use it when three months have passed from the expiration date. As LED will blink quickly to inform you of it, replace the ink pack.

Ex.) When the expiration date is April

May : Usable

June : Usable (LED lits to yellow)

July : Unusable (LED blinks to red)

## About Name

In this manual, the 2L ink pack, 2L eco case and ink IC chip are collectively described under the name of "ink cartridge".

## Caution in handling of ink packs



- Use genuine ink packs for this machine. This machine functions by recognizing the genuine ink packs. In case of troubles caused by modified ink packs or the like, it shall be out of the warranty even within the warranty period.
- If the ink pack is moved from a cold place to a warm place, leave it in the room temperature for three hours or more before using it.
- Be sure to thoroughly consume the ink in the ink pack, once it is opened, within three months. If an extended period of time has passed away after opening the cartridge tank, printing quality would be poor.
- Make sure to store ink packs in a cool and dark place.
- Store ink packs and waste ink tank in a place that is out of the reach of children.
- Request an industrial waste processor for processing of empty ink packs.
- **Precautions for new installation and replacement of new spout rubber**
  - Moisten the surface of the spout rubber with maintenance solution sufficiently before inserting. Inserting the rubber into the eco-case without moistening may damage the rubber.



•In that case, use a maintenance solution that is suitable for the ink type.

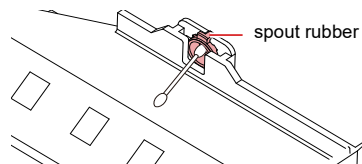
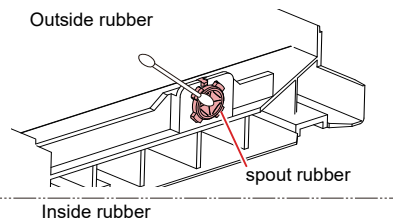

- **Precautions for using a partially used ink pack**
  - Wipe the ink off the inside of the ink pack connectors with cotton swab. Inserting the ink pack while the ink remains inside the connector part may cause ink leaking when the ink pack is used again.



•Do not insert the cotton swab too deeply. Ink may leak out of the ink pack and become unstoppable.

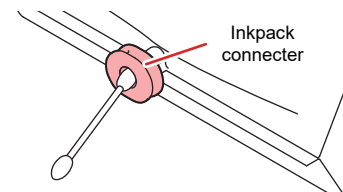



- **Precautions for setting the eco-case in the main unit**
  - Confirm that the eco-case is fully inserted. Check whether there is a gap between the MBIS Base and the eco-case. If there is a gap, insert the eco-case again.

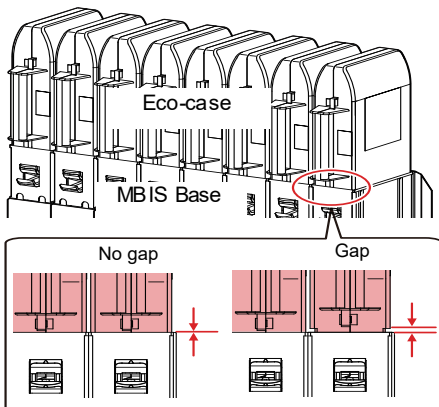

- **Method of agitating the ink pack in the eco-case**
  - When agitating the ink pack after removing (Recommended method)
    - Wipe off the ink from the connector part of the ink pack and the inside of the spout rubber before resetting.
    - Cover the connector part of the ink pack with a paper towel (Wiping Rags, etc.) before agitating.
  - When agitating the ink pack together with the eco-case
    - Spout rubber with a paper towel (Wiping Rags, etc.) before agitating.

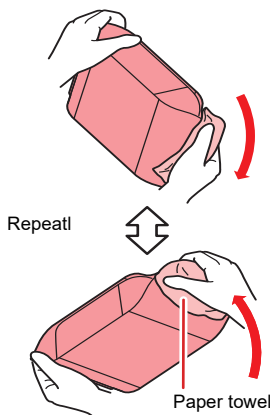

- Do not shake ink packs violently. This may result in ink leakage from the ink packs.
- Never refill the ink packs with ink. This may result in troubles. MIMAKI will not bear any responsibility for any damage caused by the use of the ink packs refilled with ink.



- Do not disassemble the ink packs.

## Media

Usable media sizes and notes for handling are described.

### Usable sizes of media

Model		TS300P-1800
Type of Recommended media	Transfer paper	
Maximum width	1,950 mm (76.8 in)	
Minimum width	210 mm (8.3 in)	
Maximum printing width	1,940 mm (76.4 in)	
Roll media	Thickness	1.0 mm or less (0.04 in or less)
	Roll outside diameter	paper media: $\Phi$ 250 mm or less ( $\Phi$ 9.8 in or less) others: $\Phi$ 210 mm or less ( $\Phi$ 8.3 in or less)
	Roll weight	40 kg or less (88.2 lb or less)
	Roll inside diameter	2 or 3 inches
	Side printed	Side facing outward
	Roll end treatment	The roll end is gently fixed to the core with weak-adhesive tape or weak glue for easy removal.

### Caution in handling of medias

Pay attention to the followings for handling of medias.



- **Use media recommended by MIMAKI to ensure reliable, high-quality printing.** Set the heater temperature to meet the characteristics of the media.
- **Pay attention to the expansion and contraction of the media.** Do not use media immediately after unpacking. The media can be affected by the room temperature and humidity, and thus it may expand and contract. The media have to be left in the atmosphere in which they are to be used for 30 minutes or more after unpacked.
- **Do not use curled media.** This may result in paper jamming. If a regular-sized coated sheet of media is rolled and stored, the coated side has to face outside.
- **Be careful to dusts on the edge face of the media.** Some rolls have dusts contained in the package gathered on the edge surface of the roll. If you use as it is, the drawing quality may be degraded due to nozzle missing or ink drops. Be sure to set the roll after removing dusts adhering on the edge face of the roll.

# Menu mode

This machine has 4 modes. Each menu mode is described below.

## NOT-READY mode

This is the mode in which the media has not been detected yet.

## LOCAL mode

Local mode is the mode for the drawing preparation state.

All the keys are effective.

The machine can receive data from the computer. However, it does not perform printing.

### Screen display in Local mode

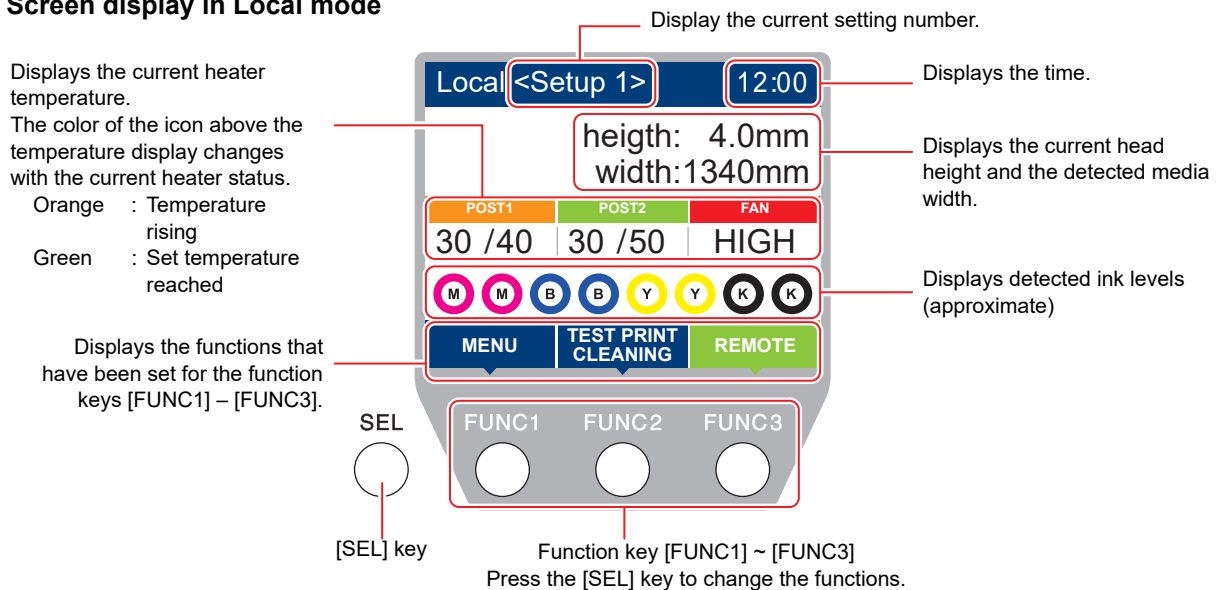

This mode permits the following operations:

- Pressing the JOG keys to set up a drawing origin and drawing area.
- Pressing the [ENTER] key to check the remaining amount of ink, the description of the cartridge error, the model name, the firmware version, and so on.

## MENU mode

To set MENU mode, press the [FUNC1] key when this machine is in LOCAL mode.  
In this mode, each function can be set.

## REMOTE mode

This machine prints the data it receives.



# Chapter 2

## Basic Operations



### This chapter

describes procedures and setting methods for ink and media preparation, and printing.

Workflow .....	2-2	Head Cleaning .....	2-17
Turning the Power ON/OFF .....	2-3	About head cleaning .....	2-17
Turning the Power ON .....	2-3	Perform head cleaning depending on the test	
Turning the Power OFF .....	2-3	printing result .....	2-17
Setting a Media .....	2-4	Setting of Media Correction .....	2-18
Adjusting the Head Height .....	2-4	Setting of Media Correction .....	2-18
Setting a roll media .....	2-5	If the Positions of Dots Shift... ..	2-18
Using the tension bar to set the roll media ..	2-8	Printing Data .....	2-19
Take-up device .....	2-10	Starting a Printing Operation .....	2-19
Setting leaf media .....	2-14	Stopping a Printing Operation .....	2-19
Changing the printing origin .....	2-15	Deleting Received Data (Data Clear) .....	2-19
Preparing for the Heaters .....	2-16	Behavior after printing has been	
Changing the Temperature Settings for the		completed .....	2-19
Heaters .....	2-16	Cutting a media .....	2-20
Test Printing .....	2-16		
Test Printing .....	2-16		

## Workflow

**1** Turning the Power ON/OFF

Referring to “Turning the Power ON/OFF” (☞ P.2-3).

**2** Setting a Media

Referring to “Setting a Media” (☞ P.2-4).

**3** Test Printing

Referring to “Test Printing” (☞ P.2-16).

**4** Head Cleaning

Referring to “Head Cleaning” (☞ P.2-17).

**5** Printing Data

Referring to “Printing Data” (☞ P.2-19).

# Turning the Power ON/OFF

## Turning the Power ON

This machine is provided with the following two power switches:

### Main power switch :

It is located on the side of this machine. Keep this switch ON all the time.

### [END/POWER] key :

Normally, use this key to turn the power ON/OFF. The nozzle clogging prevention function periodically operates even with the [END/POWER] key turned OFF when the main power switch is turned ON.

## 1 Turn the main power switch ON.

- Set the main power switch located on the side of this machine to the "I" side.

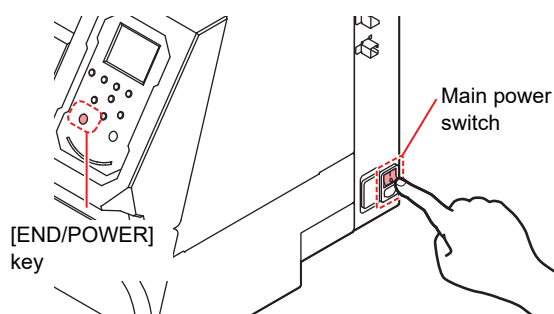

- The firmware version is displayed when the power is turned ON, and then the machine performs its initial operation.

## 2 Turn the power on, by pressing the [END/POWER] key.

- The machine enters LOCAL.

## 3 Turn ON the power of the connected PC.

**Important!**

- Turn the power ON after the front cover and maintenance cover are closed.
- The head nozzle may result in nozzle clogging if the main power switch is left OFF for a long time.

## Turning the Power OFF

When having ended the operation of the machine, turn the power OFF by pressing the power switch located on the front side.

Check the following items when turning the power OFF.

- If the machine is receiving data from the PC or if there is any data that has not been output yet
- If the head has returned to the capping station
- If any error has occurred  
(☞ P.5-8 "Error messages")

## 1 Turn OFF the power of the connected PC.

## 2 Turn the power off, by giving the [END/POWER] key a long press.

- Do not turn OFF the main power switch located on the side of the machine.
- To use this machine again, press the [END/POWER] key .

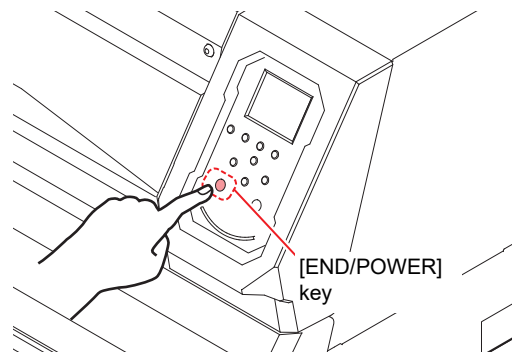

## Cautions about Turning the Power OFF

### ● Do not turn the main power switch OFF.

When the main power switch is ON, the power periodically turns ON and the nozzle clogging prevention function (flushing function) operates. When the main power switch has been turned OFF, the auto maintenance functions, such as flushing, do not operate, and this may cause nozzle clogging.

### ● Keep the front cover and the maintenance cover closed.

If the cover is opened, the auto maintenance function such as the flushing function does not work.

### ● Turn the power OFF after having checked the position of the head.

If the power is turned OFF in a state where the head has not returned to the capping station, the ink head dries, which may cause nozzle clogging. In this case, turn the power ON again and check that the head has returned to the capping station, and then turn the power OFF.

### ● Do not turn the power OFF during printing.

The head may not return to the capping station.

### ● After having turned the power switch OFF by pressing [END/POWER] key, turn the main power switch OFF.

When turning the main power switch off for moving the machine or for solving the error or the like, press the [END/POWER] key a long time on the front of the machine, check the display is turned off on the operation panel, and then turn the main power switch off.

## Setting a Media

This machine can be used with a roll media and leaf media.

For usable medias, refer to P.1-14 "Usable sizes of media".



- Take care not to drop the media on your foot when setting the media. It may cause an injury due to the media.
- When setting a roll media, work by two or more people. Otherwise, you may hurt your back by the weight of the roll media.
- Adjust the head height prior to setting the media. If the head height is adjusted after the media is set, this may cause a media jamming, deterioration of the print quality or head damage.



- With this machine, you can set media on the right side or in the center. When setting media, be sure to set it so that it covers one of the two media sensors on the back of this machine.
- If setting the media in the center, use the take-up extension cable.
- The head height is adjustable according to the purpose of use.

### Adjusting the Head Height

Set the head gap (height from the media to the nozzle plane of the heads).

When the carriage is to move above the platen for printing or maintenance, it moves while keeping the head gap at the preset value.

The upper limit of the head gap varies with media thickness.

Available setting values: [2.0 mm to 7.0 mm] (in units of 0.1 mm)

- 1** Press **FUNC1 (MENU) → ▾** (twice) → **ENTER** key in LOCAL.

- MACHINE SETUP MENU will be displayed.

- 2** Press **▲ ▾** to select "HEAD HEIGHT", and press the **ENTER** key.

- Move the carriage to the platen.

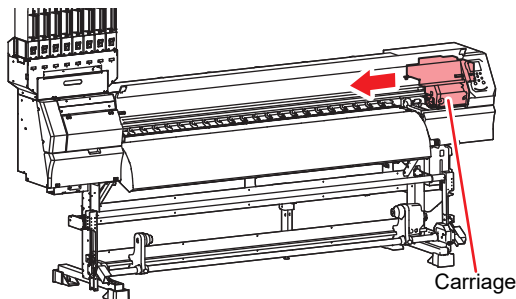

- 3** Loosen the height-adjusting screw in front, and press the **ENTER** key.

- Loosen the screws, rotating each by one turn of a standard screwdriver.

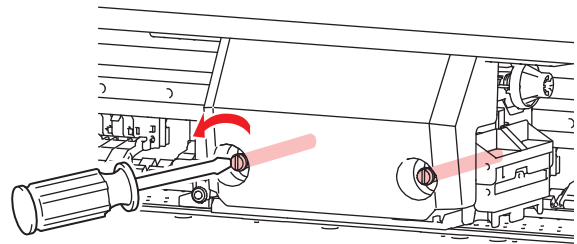

- 4** Adjust the height-adjusting handle according to the media.

- Rotate **2** while pressing **1**.
- Look at the display and adjust to an appropriate value.

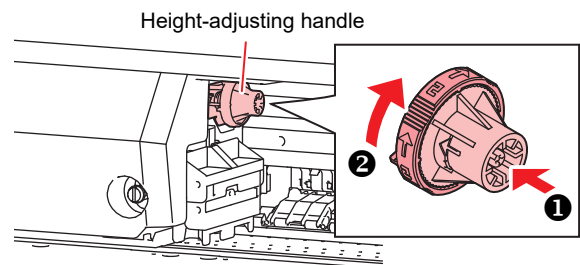

- 5** Fix the carriage.

- Fasten the screw securely.

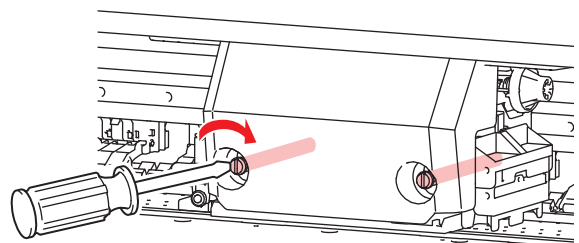

- 6** Press the **ENTER** key.

- The carriage automatically returns to the station.

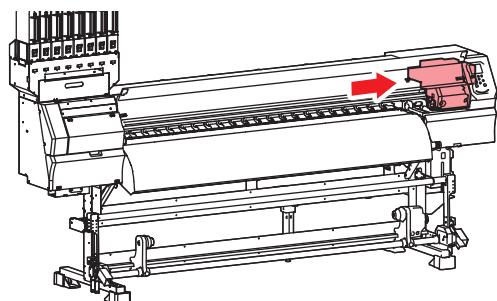

- 7** Press the **END/POWER** key several times to end the setting.



## Setting a roll media

Set a roll media to the roll media hanger located on the back of this machine.

- 1 Move the roll holder located in the back of the device to the direction of the middle of the device.**

- Loosen the roll holder fixing screw and then move it.

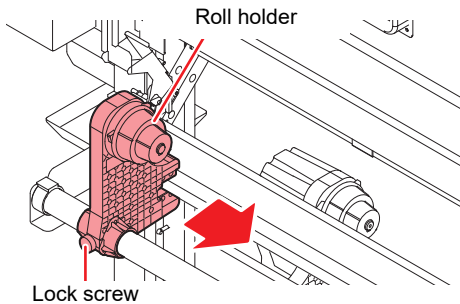

- 2 Check the clamp lever is lowered.**

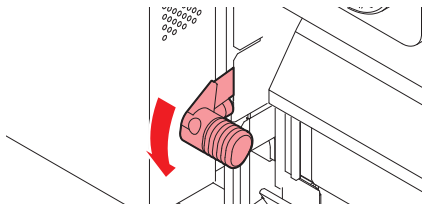

- 3 Move the roll holder to the roll setting position.**

**If setting the media on the right side**

- Check the roll stopper is not caught between the roll stopper arm and this machine.

Set the base position of roll holder within this range.

Roll Holder Set Position	3 Inch Roll Media	2 Inch Roll Media
--------------------------	-------------------	-------------------

- There are two types of the internal diameter of the roll media paper tube: 2 inch and 3 inch.

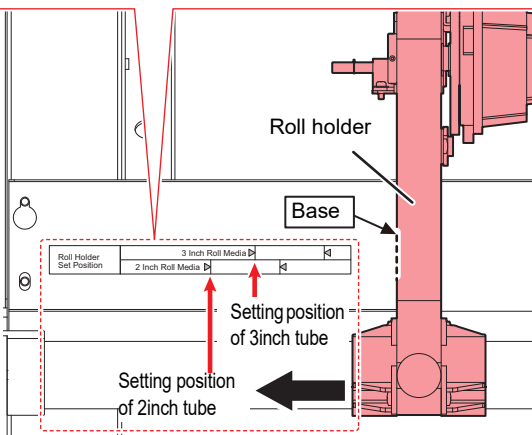

**Roll Holder Side (The back of this machine)**

**If setting the media in the center**

- Move the roll holder so the media's set position is in the center of this machine.

- 4 Tighten the roll holder fixing screw.**

- Check the Step 2 to 3 again.

- 5 Move the roll guide stay to match the position to set the media in.**

- After moving the stay, set down the adjuster foot.

- Turn the screw on the adjuster foot once.

- Make sure that the adjuster foot is fixed firmly to the floor.

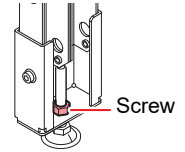

**If setting the media on the right side**

- Move the roll guide stay so that it is to the left of the right roll holder, as seen from the rear of the machine.

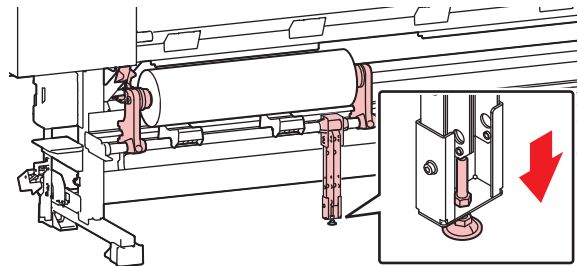

**If setting the media in the center**

- Move the roll guide stay to the center of the roll holder.

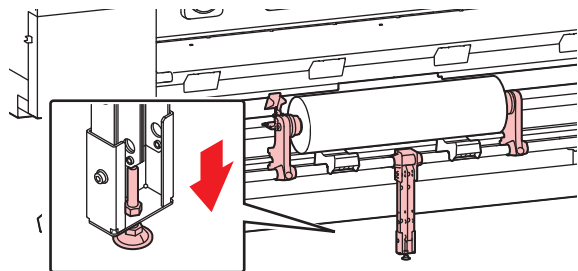

- 6 Set the left end of the core of the roll media on the left roll holder.**

- Push the roll media onto the roll holder until the roll core is all the way seated.

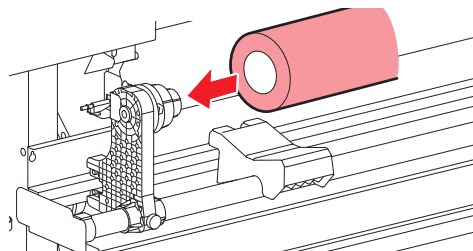

- 7** Loosen the screw of the right side roll holder then insert the holder into the core of the roll media.

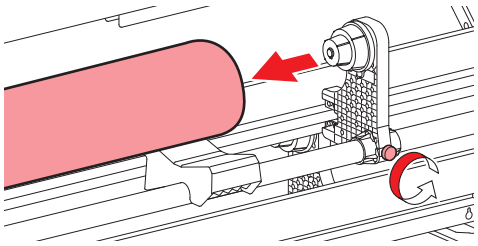

- 8** Raise the clamp lever in the rear of this machine.

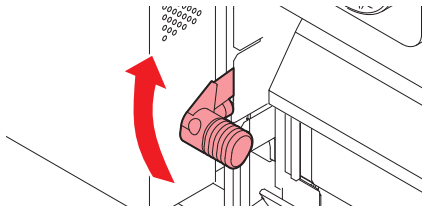

- 9** Insert the roll media in this machine.

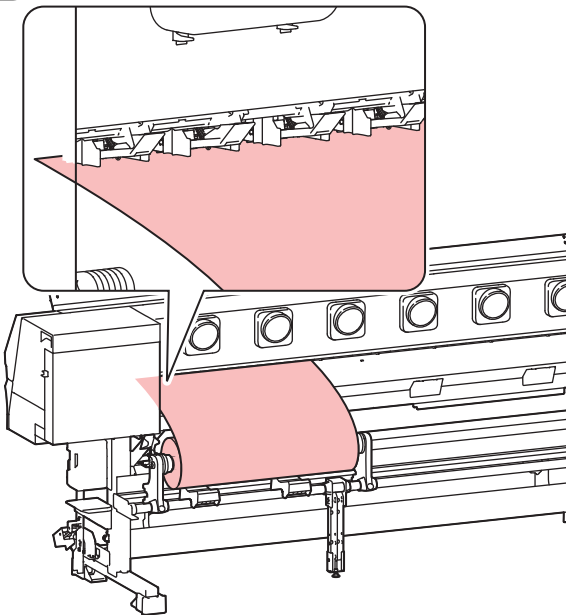

• The roll media can be smoothly inserted by slanting the media.

- (1) Pull the media out of the roll to the head of the platen.

- (2) Insert the media between the platen and the pinch roller.  
 • Pull the media out of the roll so that the media can be grasped from the front of the machine.



• If you set the roll media in the center, to prevent the media from moving, pull down the roll stopper towards you and insert the pin to temporarily lock it.

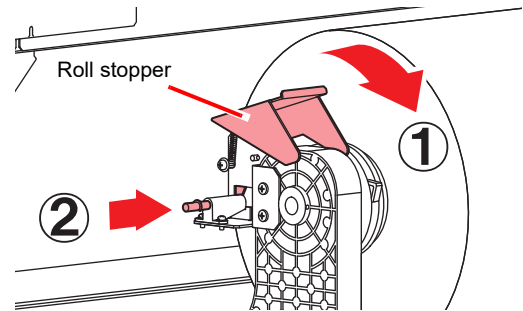

- (3) Push down the clamp lever from the back of this machine.  
 • The media is held.

- 10** Pull out the roll media out.

- (1) Open the front cover.  
 (2) Raise the clamp lever from the front of this machine.  
 (3) Pull out the roll media gently and then stop pulling when locked lightly.

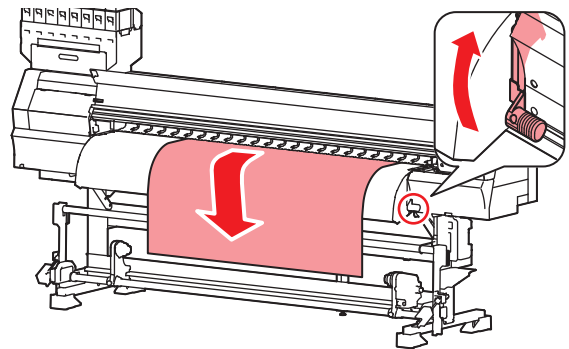

• If you set the roll media in the center, the lock will not engage.

- 11** Make the roll media even then lower the clamp lever.

• Pulling several positions of the media lightly, Lower the clamp lever after confirming that the amount of the roll media pulled out is almost even.

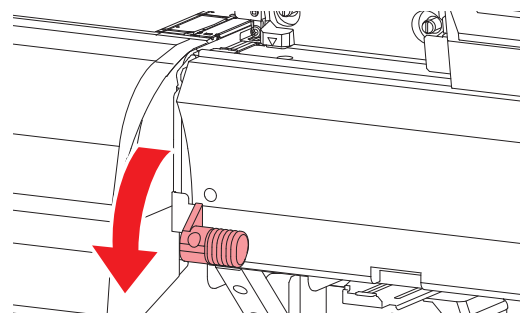

## 12 Hold the media with the media press gently.

- Set the media so that no media sticks out from the right end pinch roller to the right side.
- When using a thick media, remove the media press from the media before printing.

In this case, set the machine setup of "In this case, set the machine setup of "Setting the Display of Media Detection" to "MANUAL" (☞ P.3-17), and refer to P.2-9 "Setting of the manual media width setting" and set the media width.

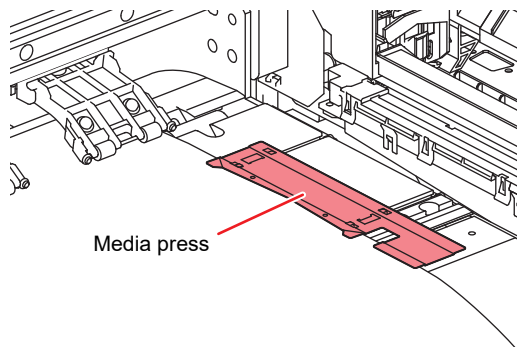

- When installing the media, align the media's right edge with the groove in the platen. Placing the media rightward of the groove will make it rise up if it moves obliquely, and this could cause damage to the head.
- This machine detects the media width using the media presses set to the left and right of the media. Be sure to set the media presses.
- If a media is misaligned to the right/left more than fixed position, a error message "MEDIA SET POSITION R" is displayed. Set the media again.

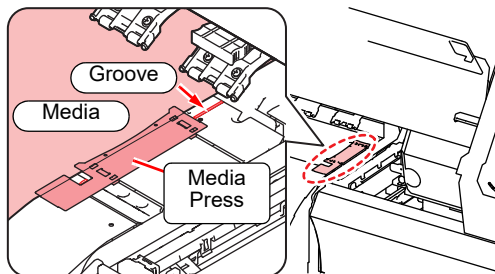

## 13 Set an empty core of the roll media on the take-up device.

- After setting the empty core, set down the take-up legs.

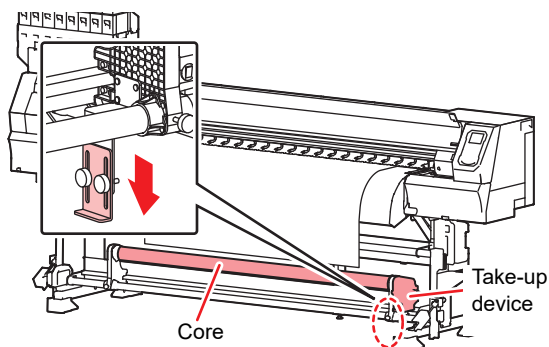

## 14 Close the front cover.

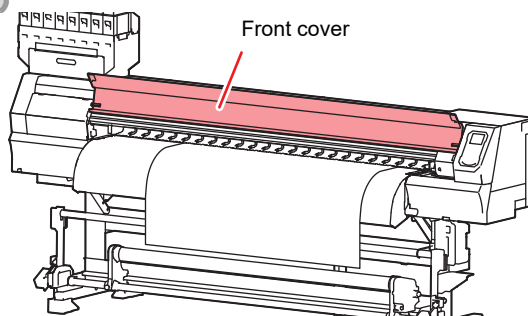

## 15 Press to select "ROLL".

- Detects the media width.
- When [MEDIA DETECT] of the machine setup is "MANUAL" (☞ P.3-17), refer to P.2-9 "Setting of the manual media width setting" and enter the media width.
- When [MEDIA RESIDUAL] of the machine setting is "ON" (☞ P.3-17), the screen for entering media remaining amount is displayed after detecting the media width. (☞ P.2-9)

## 16 Secure the media on the take-up device. (☞ P.2-10)

- (1) Feed the media up to the core of the roll media of the take-up device by pressing [].
- (2) Fix the middle of the media with adhesive tape.
- (3) In the same manner, fix the left side and right side of the media.
  - Make sure that there is no slack or wrinkle on the media in such condition that the roll media is pulled to right and left evenly, and then stick the tape.

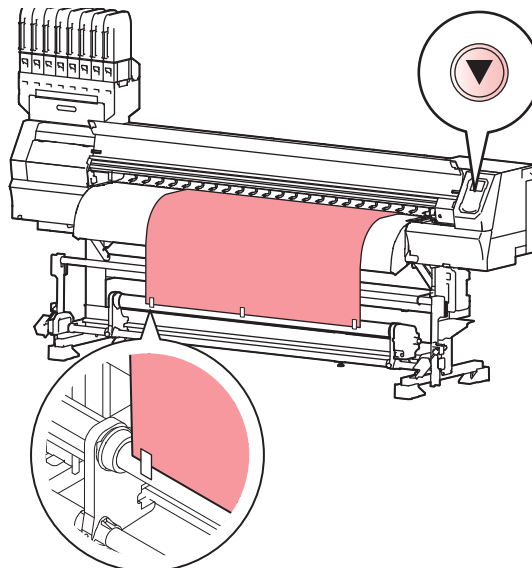

## Using the tension bar to set the roll media

When setting media, read the following notes carefully.

- 1** Set the take-up tension bar to "ON" in "Setting Take-up unit" of the machine setup. (P.3-16)
- 2** Perform Steps 1 to 12 for "Setting a roll media".
- 3** Close the front cover.

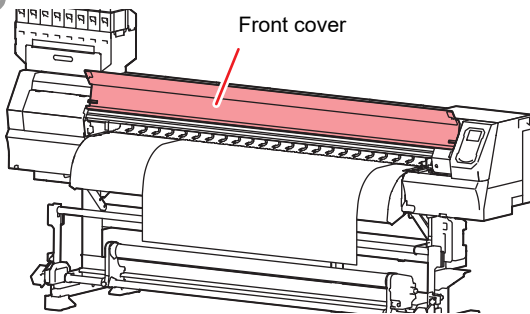

- 4** With switches of the take-up device, roll up the media about once.

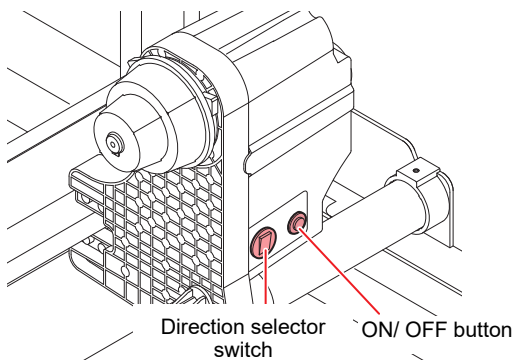

- (1) Set the take-up direction using the direction selector switch on the left, turn the ON/OFF button on the right to ON, and then take up the media.
- (2) Just before the media stretched tight, turn the right ON/OFF button to OFF to stop.

- 5** Press **◀** to select "ROLL".

- Detects the media width.
- When [MEDIA DETECT] of the machine setup is "MANUAL" (P.3-17), refer to P.2-9 "Setting of the manual media width setting" and enter the media width.
- When [MEDIA RESIDUAL] of the machine setting is "ON" (P.3-17), the screen for entering media remaining amount is displayed after detecting the media width. (P.2-9)

- 6** Secure the media on the take-up device. (P.2-10)

- (1) Feed the media up to the core of the roll media of the take-up device by pressing [▼].
- (2) Fix the middle of the media with adhesive tape.
- (3) In the same manner, fix the left side and right side of the media.
  - Make sure that there is no slack or wrinkle on the media in such condition that the roll media is pulled to right and left evenly, and then stick the tape.

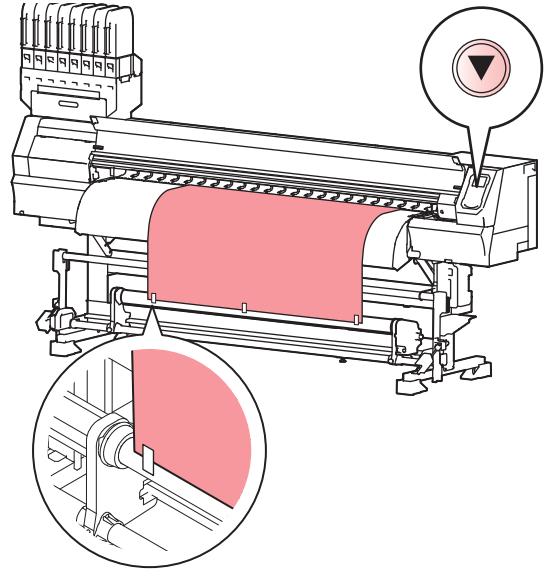

- 7** After displaying "Detect Take-up unit", press **▶** and then select "START".

- When the media is set inward, feed the media for approximately 110 mm after this.

- 8** Lift the tension-bar down slowly.

- Unlock the tension-bar, and then lift it down.
- The tension bar is initialized. Once initialization is successful, the printer starts the winding diameter detection. When winding diameter detection is complete, the local screen is displayed.
- If initialization fails, "Detect failure" is displayed. Return the tension bar to the standby position.
- If detection fails and you want to start detection again, raise and lower the clamp lever, and perform the operation from step 5.

## Entering the media remaining amount

When [MEDIA RESIDUAL] of the machine setup is "ON" (☞ P.3-17), the screen for entering media remaining amount is displayed after detecting the media width.

- 1 Display the screen for entering media remaining amount.

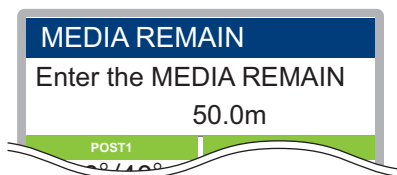

- 2 Press **▲▼** to enter the media remaining amount.

- 3 Press the **ENTER** key.

## About the media residual print

When [MEDIA RESIDUAL] of the machine setup is "ON" (☞ P.3-17), You can print a list of print the current date and media remaining.

- 1 In Local, Press **▲▼◀▶**.
- It enters into the origin setting mode.

- 2 Press the **FUNC3** key.
- Appear the confirmation screen of media remaining print.

- 3 Press the **ENTER** key.
- Media residual print starts.

## Setting of the manual media width setting

When [MEDIA DETECT] of the machine setup is "MANUAL" (☞ P.3-17), set the media width in the following method.

- 1 Display the "MEDIA DETECT" screen.

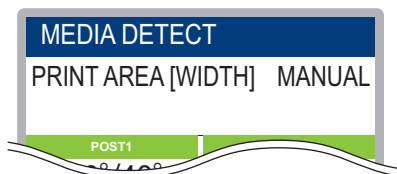

- 2 Select the print area setting method.

- When setting the print area, use either "Manual" to set the right and left edge of the media using the jog key, or "Media width input mode" to set the right edge of the media after inputting media width.
- When "Manual" is selected, proceed to Step 3. And when "Media width entering mode" is selected, proceed to below.

- (1) Press **▲▼**, and enter the media width.
- (2) Press the **ENTER** key, and perform after step3.

- 3 Press **◀▶** to set a light point of the LED pointer to the right edge position of the media.

- Align the light of the LED pointer incorporated in the carriage to the right edge of the media.



- 4 Press the **ENTER** key.

- Next, the screen to enter the left edge position of the media is displayed. When "Media width entering mode" is selected on step 2, this setting is end without display this screen.

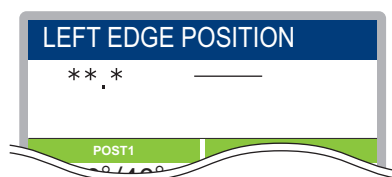

- 5 Press **◀▶** to set a light point of the LED pointer to the left edge position of the media.

- In the same manner as in step 3, align the light of the LED pointer to the left edge of the media.

- 6 Press the **ENTER** key.

**Important!**

- Be careful not to set the position beyond the media range, as it may cause printing or cutting outside the media.

### Entering media thickness

If the thickness input setting in [MEDIA DETECT] in machine setup is turned "ON" (☞ P.3-17), set the media thickness as follows:

- 1 Display the screen for entering the media thickness.

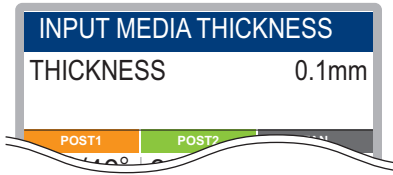

- 2 Press to enter media thickness.

- 3 Press the key.

### Take-up device

With the switch of the narrow take-up device, select the take-up direction of the media or others.

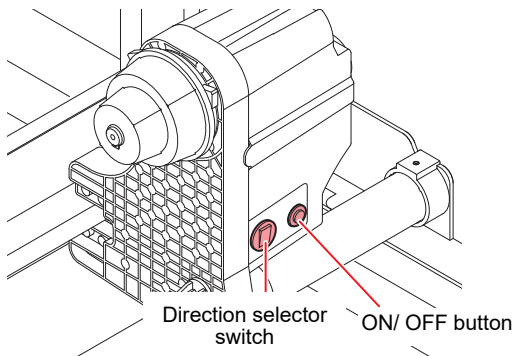

Take-up unit	Direction selector switch	UP (REVERSE)	The take-up device winds the media with the printed side facing in.
		DOWN (FORWARD)	The take-up device winds the media with the printed side facing out.
	ON/OFF button	Turns the winding motion on/off. (When you press the button and operate the take-up device, the device keeps taking up the media until you press the button again. *1)	

\*1. You can also change the setting so that the taking-up operation only lasts while the ON/OFF button is being pressed. For details, refer to "Setting Take-up unit" (☞ P.3-16) in machine setups.

### Setting the torque limiter

The take-up device is provided with a torque limiter. The take-up torque can be adjusted with the torque limiter. (The torque limiter is set to "Medium" at delivery.) If the tension is too strong to use a thin sheet of media, lower the take-up torque with the torque limiter.

#### Clockwise turn :

Increases torque (a heavy and thicker media such as tarpaulin or the like)

#### Counterclockwise turn :

Decreases torque (For light media)

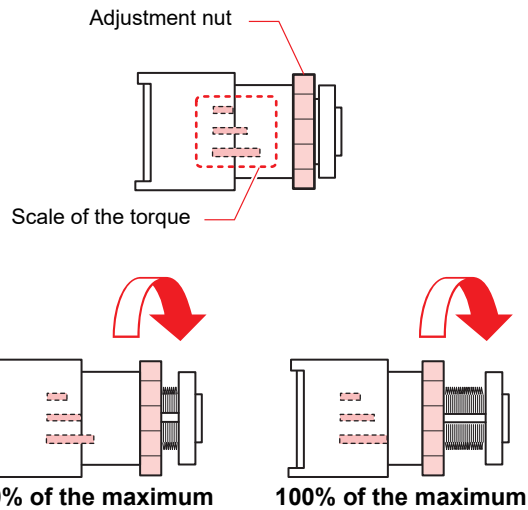

**Important!**

- **When the torque limiter is adjusted too weak ;**  
The media can not be taken up firmly.
- **When the torque limiter is adjusted too strong ;**  
The slack may occur depending on the media and cause influence on the image quality.
- When using the tension bar, adjust the torque limiter at about 75 to 100% of the maximum torque.  
When adjusting the torque limiter, use the torque adjustment handle supplied.

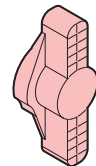

- There are the following two methods for taking up the media on printer:
  - (1) Only use the take-up device to take up the media
  - (2) Use the tension bar to take up the media

## Installing the counter weight for adjusting the tension-bar weight (1)



- If the large / small two types of counter weight (large (100g x 4 sheets) / small (50g x 20 sheets)) are attached, install a counter weight in the following manner.
- Check the tension of the media and attach an appropriate number of weights.

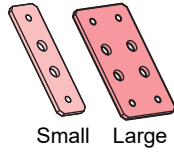

Install the proper number of the counter weight depending on the media type.  
 You can attach the counter weight up to 12 (Large : 2, Small : 10) each for right and left.

Media condition	Solution
Ruck is generated in the media feeding direction.	The tension applied on the media is too strong.
The media skews at printing.	Remove the weight, and lighten the tension bar.
The media sags and the machine cannot take it up beautifully.	The tension applied on the media is too weak.
The media floats on the platen.	Attach the weight, and make the tension bar heavier.

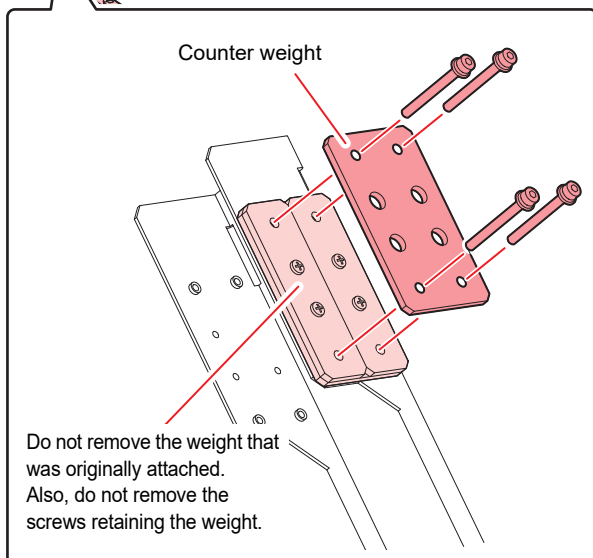
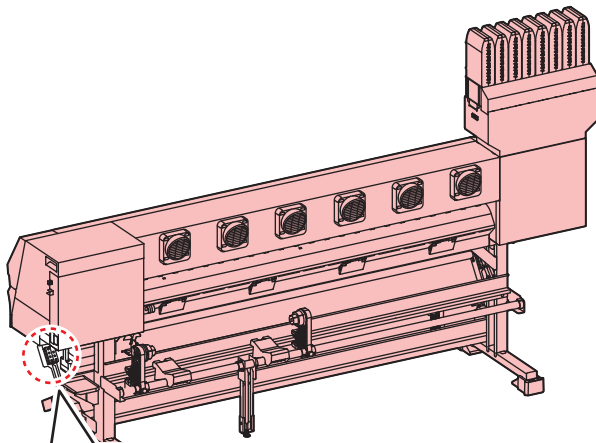

**Important!**

### Number of counter weights you can attach

- The number of counter weights you can attach differs depending on the outer diameter after taking up the media.
- Instead of the torque limiter attached to the printer take-up device, you can attach the motor direct-connection unit supplied with the AMF kit. In this case, the number of counter weights attached to the tension bar differs.

#### For torque limiter

Roll outside diameter*1	Winding direction	Maximum number
Φ80 mm	Wound inward	12 (Large x 2 + Small x 10)
	Wound outward	12 (Large x 2 + Small x 10)
Φ150 mm	Wound inward	12 (Large x 2 + Small x 10)
	Wound outward	4 (Large x 0 + Small x 4)
Φ250 mm	Wound inward	6 (Large x 0 + Small x 6)
	Wound outward	0

\*1. When using media with the diameter that is out of the range specified above, see the table below and check the maximum number.

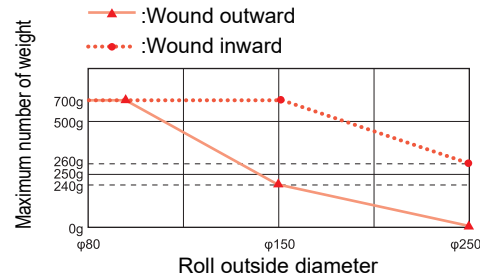

#### For motor direct-connection unit

Roll outside diameter*1	Winding direction	Maximum number
Φ150 mm	——	12 (Large x 2 + Small x 10)
Φ250 mm	——	6 (Large x 0 + Small x 6)

\*1. When using media with the diameter that is out of the range specified above, see the table below and check the maximum number.

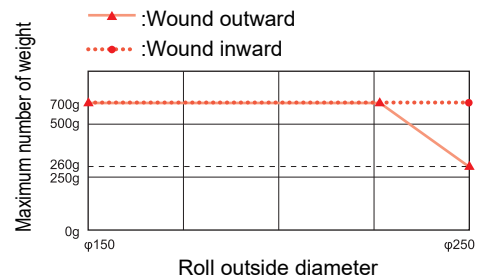

- Do not attach more than the maximum number of counter weights.
- Not to lose the unused counter weight, put it in the storage box.

## Installing the counter weight for adjusting the tension-bar weight (2)



- If the counter weight (50g x 28 sheets) of the right figure is attached, install a counter weight in the following manner.
- Check the tension of the media and attach an appropriate number of weights.

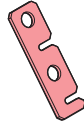

Install the proper number of the counter weight depending on the media type.  
You can attach the counter weight up to 14 each for right and left.

Media condition	Solution
Ruck is generated in the media feeding direction.	The tension applied on the media is too strong. Remove the weight, and lighten the tension bar.
The media skews at printing.	The tension applied on the media is too weak. Attach the weight, and make the tension bar heavier.
The media sags and the machine cannot take it up beautifully.	
The media floats on the platen.	

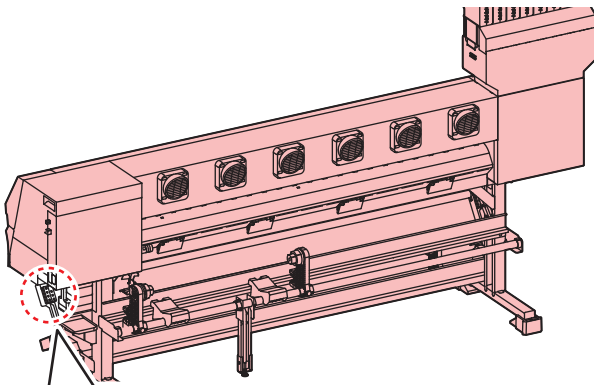

Do not remove the weight that was originally attached. Also, do not remove the screws retaining the weight.

Mounting screw  
Loosen the screws when removing the counter weight.

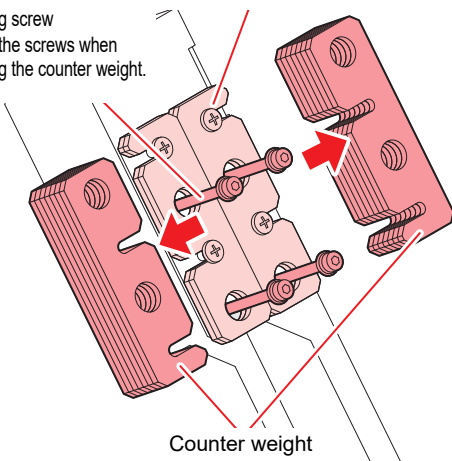

**Important!**

### Number of counter weights you can attach

- The number of counter weights you can attach differs depending on the outer diameter after taking up the media.
- Instead of the torque limiter attached to the printer take-up device, you can attach the motor direct-connection unit supplied with the AMF kit. In this case, the number of counter weights attached to the tension bar differs.

#### For torque limiter

Roll outside diameter <sup>*1</sup>	Winding direction	Maximum number
Φ80 mm	Wound inward	14
	Wound outward	14
Φ150 mm	Wound inward	14
	Wound outward	4
Φ250 mm	Wound inward	6
	Wound outward	0

\*1. When using media with the diameter that is out of the range specified above, see the table below and check the maximum number.

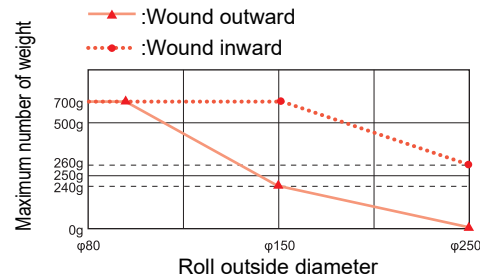

#### For motor direct-connection unit

Roll outside diameter <sup>*1</sup>	Winding direction	Maximum number
Φ150 mm	—	14
Φ250 mm	—	6

\*1. When using media with the diameter that is out of the range specified above, see the table below and check the maximum number.

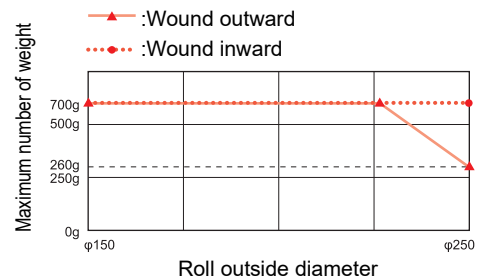

- Do not attach more than the maximum number of counter weights.
- Not to lose the unused counter weight, put it in the storage box.



## Replacing the torque limiter

When using the take-up unit and tension bar to take up the media, you can replace the torque limiter with the motor direct-connection unit.

**Important!**

- When setting the media using the torque limiter and tension bar and if you want to attach more counter weights than the specified limit, replace it with the motor direct-connection unit.
- For printer, you can change to winding method using the tension bar while the media is being wound up by the take-up device. In that case, do not replace the torque limiter with the motor direct-connection unit.
- When using the motor direct-connection unit, you can only use the winding method that uses both tension bar and take-up device. You cannot change the winding method during printing. (☞ P.2-14 "When you want to change the take-up method to the method using the tension bar during printing")

### 1 Remove the torque limiter.

- Remove the thumbscrew, and then remove the torque limiter.

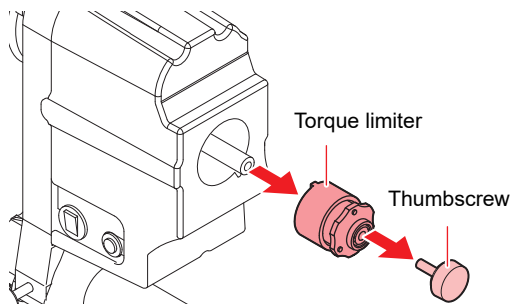

### 2 Attach the motor direct-connection unit .

- (1) Insert so that the projection of the motor direct-connection unit match the groove of the take-up device.

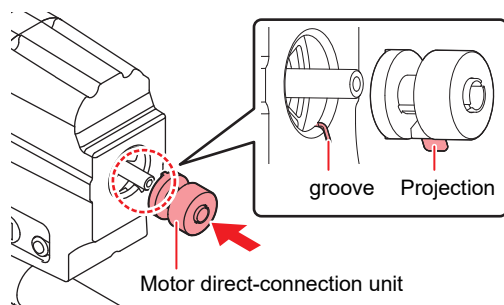

- (2) Attach it so that the tip of the shaft of the take-up device matches the surface of the motor direct-connection unit.

**Important!**

- As shown in the figure, attach it so that the tip of the shaft of the take-up device matches the surface of the motor direct-connection unit. If the tip of the shaft and the surface of the motor directly connected unit does not match, the take-up of the media will not run well.

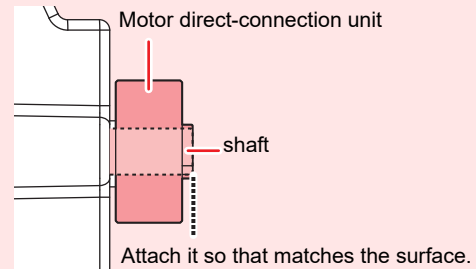

- If it is hard to mount the motor direct-connection unit, mount it while turning the roll holder.

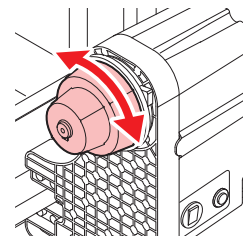

- (3) Use the thumb screw to fix the motor direct-connection unit

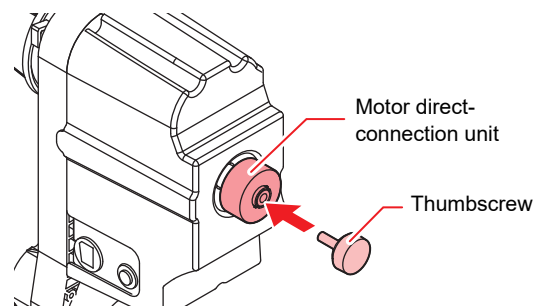

- When replace from Motor direct-connection unit to Torque limiter, replace it in the same manner.

## When you want to change the take-up method to the method using the tension bar during printing

While printing using only the take-up device, you can change the take-up method to the method using the tension bar.

### 1 Press **SEL** → **FUNC2** → **ENTER** while printing.

- Winding operation stops.
- When the media is set inward, the media is fed to the position where the tension bar can be set. (The countdown for the feeding amount is displayed.)

### 2 Lift the tension-bar down slowly.

- Unlock the tension-bar, and then lift it down.
- When the media is set inward, wait until the count becomes "0", and then lower the tension bar.

### 3 Control to switch to the winding method using the tension bar.

- (1) Detect the tension bar origin.
- When the switching operation fails, the result is displayed, and then winding operation using the take-up device continues. Return the tension bar to the locking position.

## Setting leaf media

Unlike roll media, leaf media does not need to be retained with the roll holders.

### 1 Open the front cover, and then raise the clamp lever.

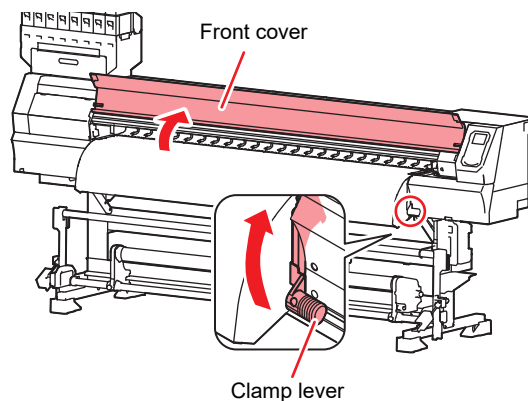

### 2 Insert the leaf media between the platen and the pinch rollers, and push down the clamp lever.

- Set the media so that no media sticks out from the right end pinch roller to the right side.

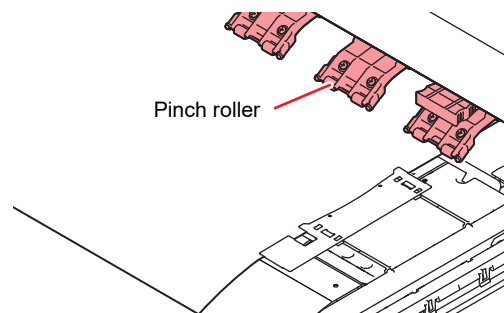

### 3 Hold the media with the media press gently.

- Set the media so that no media sticks out from the right end pinch roller to the right side.
- When using a thick media, remove the media press from the media before printing. In this case, set the machine setup of "Setting the Media Detection" to "MANUAL" (P.3-17), and refer to P.2-9 "Setting of the manual media width setting" and set the media width.

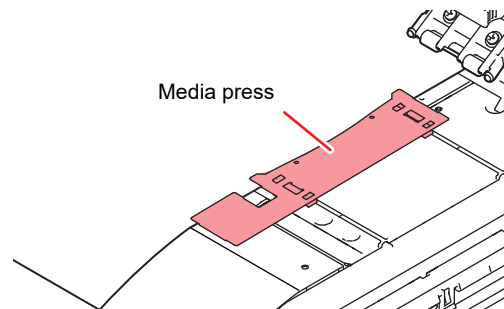

## 4 Push down the clamp lever and then close the front cover.

- Set the media straight.

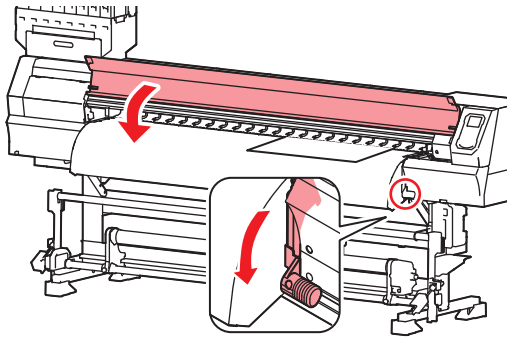

**Important!**

- Set the media on the black part of the platen so that it comes out approximately 40 mm. If it is shorter than that, it may not be able to perform the media detection.

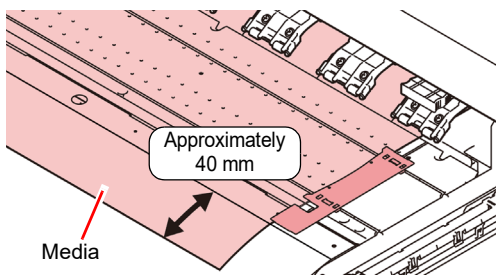

## 5 Press **▶** to select "LEAF" .

## 6 The media detection is started.

- (1) The media width is detected.
- (2) The media is fed then the rear end of media is detected.
- (3) It returns to the Local when the detection is completed.

## Notes when using media press



- When installing the media, align the media's right edge with the groove in the platen. Placing the media rightward of the groove will make it rise up if it moves obliquely, and this could cause damage to the head.
- If a media is misaligned to the right/left more than fixed position, a error message "MEDIA SET POSITION R" or is displayed. Set the media again.

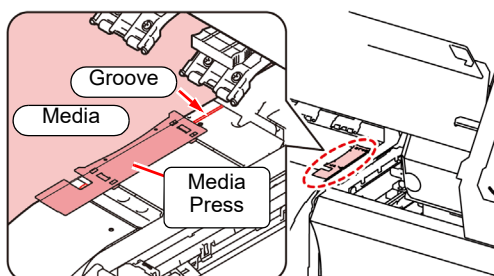

## Changing the printing origin

The position of the printing origin can be changed. Moving the LED pointer to the changing position and deciding the position.

### 1 In Local, Press **▲▼◀▶**.

- It enters into the origin setting mode.

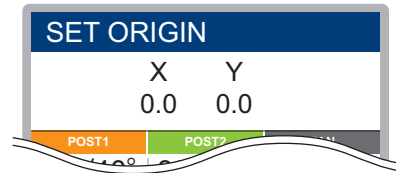

### 2 Press **▲▼◀▶** to set a light point of the LED pointer to the changing position.

- Select the carriage and media, moving the point with **▲▼◀▶**.

### 3 After determining the origin, press the **ENTER** key.

- The printing origin is changed.

## Typical setting position of printing origin

The printing origin in the depth direction (X') is positioned at about 75 mm rearward from the slot for cutting on the platen. The printing origin in the scanning direction (Y') is positioned at 15 mm from the right end of the media. The value in the scanning direction (Y') can be changed using [MARGIN] in FUNCTION mode. (P.3-8) This can be changed by using the Jog key.

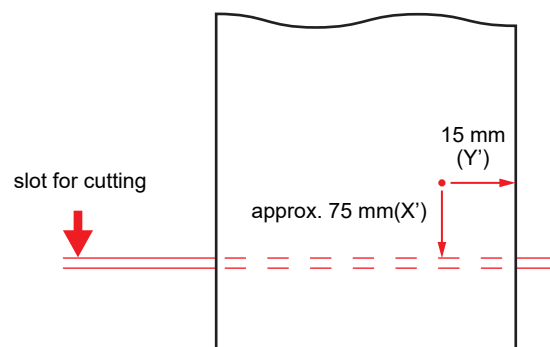

# Preparing for the Heaters

## Changing the Temperature Settings for the Heaters

You can change/save the temperature settings for the heaters with "Heater" or "OPTION HERATER" of the setting mode. (☞ P.3-6, P.3-7)

Here, changing method of the temperature set in the setting mode is explained.

Set the heater temperature according to the characteristics of the media you use.

The temperature of the heaters has been set to "OFF" as default.

Appropriate temperature adjustment can be made because the temperature can be adjusted even during printing.

It may take several minutes to tens of minutes for the set temperature to be reached, depending on the ambient temperature.

- 1** Press the **[SEL]** key, and then press the **[FUNC2]** (Heater) in LOCAL.

  - The heater temperature adjustment screen will be displayed.

- 2** Press **[▲][▼][◀][▶]** to set the temperature of each heater.

**Heater selecting** : Select with **[◀][▶]**  
**Temperature setting** : Set with **[▲][▼]**

  - The heater starts to get hot.

- 3** The heating of the heater stops.

  - When the heater temperature reaches the set temperature, the heater icon lights in green.

- 4** Press the **[ENTER]** key to stop heating.

  - The screen returns to LOCAL.

- Important!**
- Use this machine under 20 to 30°C. The temperature may not reach the set value due to the environmental temperature condition.
  - The TS300P has two heaters (POST1, POST2) in the machine, and an optional fan heater. Normally, printing is possible at ±3°C of the set temperature. However, the heaters are easily affected by heat from other heaters, so printing is possible using the following specifications.

Heater type	Heater specifications
POST1	<ul style="list-style-type: none"> <li>Maximum set temperature= 50°C (However, a temperature higher than POST2 cannot be set.)</li> <li>Heat from POST2 affects this heater, so you print even if the upper temperature range is more than 3°C.</li> </ul>
POST2	<ul style="list-style-type: none"> <li>Maximum set temperature= 60°C</li> <li>If you have installed the optional fan heater, the optional fan heater affects this heater, so you print even if the upper temperature range is more than 3°C.</li> </ul>



- Press **[FUNC3]** (OFF) in Step 2 to turn all heaters OFF. Or, press **[FUNC1]** to raise the POST1/POST2 heaters in 10°C increments.

# Test Printing

Print a test pattern to check that there are no discharging defects such as nozzle clogging (slight touching of ink or nozzle missing).

## Relationship between head row and test pattern

The relations between head row and test pattern print position are as follow.

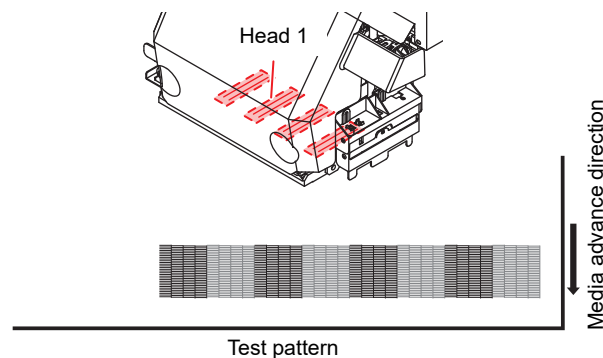

## Note on test printing

- Important!**
- When using leaf media, set a media of more than A3 size put horizontally. If a media with narrow width is set, printing will only be conducted to midway.
  - When using a roll media, rewind the media by hand before printing so that it is not loose. When the roll media has not been rewound tightly, it may cause image quality to deteriorate.

## Test Printing

Print a test pattern to check that there are no discharging defects such as nozzle clogging (slight touching of ink or nozzle missing).

In addition, you can select the orientation of the test pattern to print from two types in order to perform test printing repeatedly. Select one depending on your use.

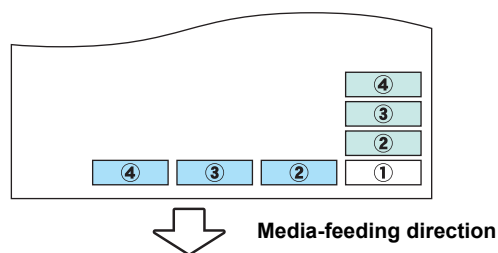

- : When the the test pattern orientation is "FEED DIR."
- : When the the test pattern orientation is "SCAN DIR."

Check before test printing.
• If a media has been set ☞ P.2-4
• If the origin position has been set
• If the head gap has been adjusted ☞ P.2-4
• If the necessary settings have been configured for nozzle recovery ☞ P.4-13

**1** Press the **FUNC2** (TEST PRINT/CLEANING), and then press the **ENTER** key in LOCAL.

- The test pattern orientation screen will be displayed.

**2** Press **▲▼** to select the test pattern orientation (SCAN DIR./ FEED DIR.).

- The orientation selected here will be reflected on when you will print next time.
- When performing test printing after having changed the orientation from "SCAN DIR." to "FEED DIR.", the line is fed to the position of the first test printing.

**3** Press the **ENTER** key.

- The NOZZLE RECOVERY setting screen will be displayed.

**Important!**

- If no recovery nozzles are registered in "Nozzle Recovery" in the maintenance menu (☞ P.4-13), or if the test print setting is not set to "ON" (☞ P.4-14), the test print begins. Proceed to step 6.

**4** Press **▲▼** to select NOZZLE RECOVERY function ON/OFF.

- The orientation selected here will be reflected on when you will print next time.

**ON** : Print the pattern of nozzles with recovered nozzles by other nozzles, which have been registered by the nozzle recovery of the maintenance menu.

**OFF** : Print the pattern without Nozzle Recovery.

**5** Press the **ENTER** key.

- Test printing starts.
- When the printing has been completed, the screen returns to LOCAL.

**6** Check the printed test pattern.

- When the result is normal, end the operation.
- When the result is abnormal, perform head cleaning. (☞ P.2-17)

**Normal pattern**

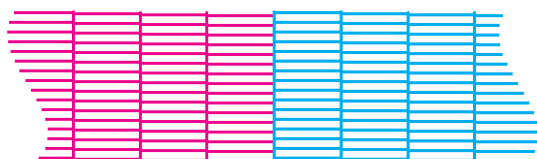

**Abnormal pattern**

Nozzles are dirty

Clogged with ink

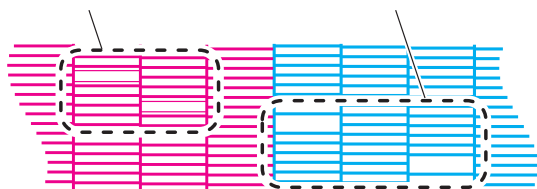

## Head Cleaning

### About head cleaning

Check the printed test pattern result and perform cleaning depending on the status.

Select one from the three types below:

**NORMAL** : When any line is missing

**SOFT** : When only head wiping is needed (when lines are bent)

**HARD** : When poor image quality cannot be improved even by NORMAL or SOFT cleaning

### Perform head cleaning depending on the test printing result

There are three types of head cleaning. Use one by checking the test pattern.

**1** Press the **FUNC2** (TEST PRINT/CLEANING) **→▼→** **ENTER** key in LOCAL.

- CLEANING MENU will be displayed.

**2** Press **▲▼** to select the cleaning type.

- **NORMAL** : Select this if any line is missing.

- **SOFT** : When only head wiping is desirable. (in case of bent lines)

- **HARD** : Select this if inferior printing cannot be improved even by [NORMAL] or [SOFT] cleaning.

**3** Press the **ENTER** key.

**4** Perform test printing again, and check the result.

- Repeat the cleaning and the test printing until the printing result becomes in normal.



- When the image quality is not improved after the head cleaning.

- Clean the wiper and ink cap. (☞ P.4-6)

- Wash the head nozzle. (☞ P.4-7)

## Setting of Media Correction

Correct the media feed amount to match the type of media you are using.

If the correction value is not appropriate, stripes may appear on the printed image, thus resulting in a poor printing.



- On completion of [MEDIA COMP.] during use of a roll media, the media returns to the printing origin. Then the roll media in the rear of this machine will slacken. Before printing, take up the slack in the roll media by hand; a loose roll media can result in an inferior image quality.
- When printing with a take-up device, set the media first and then perform media correction.

### Setting of Media Correction

A pattern for media correction is printed and a media-feeding rate is corrected.



- Two bands are printed in the correction pattern.
- Make adjustment so that an even color density is obtained in the boundary between the two bands.

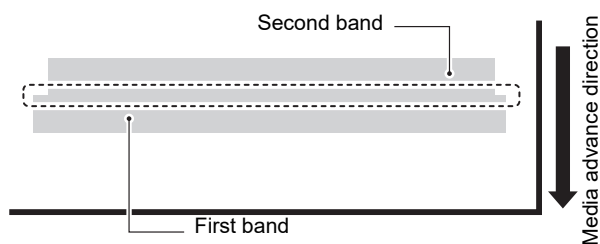

**1** Set a media. (☞ P.2-4)

**2** Press the **[SEL]** key, and then press the **[FUNC2]** (ADJUST) in LOCAL.

- ADJUST MENU will be displayed.

**3** Press the **[ENTER]** key twice to print the correction pattern

**4** Check the correction pattern and enter a correction value.

- A screen for entering the correction value will be displayed.
- **Enter a correction value in "+":**  
The boundary between the two bands is widened.
- **Enter a correction value in "-":**  
The boundary between the two bands is narrowed.
- When you change the correction value by "30", the width of the boundary changes by about 0.1 mm.

## If the Positions of Dots Shift...

When the condition for printing (media thickness/ink type/ etc.) has been changed, perform the following operation to correct the ink drop position for bidirectional (Bi) printing and obtain the proper printing result.



- When using leaf media, set a media of more than A3 size put horizontally. If a media with narrow width is set, printing will only be conducted to midway.

### Example of a Printed Pattern

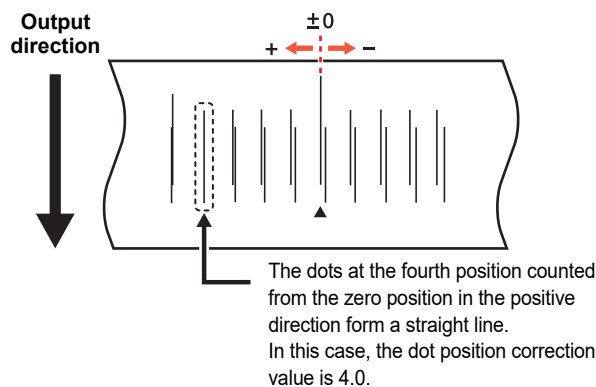

**1** Press the **[SEL]** key, and then press the **[FUNC1]** (ADJUST) in LOCAL.

- ADJUST MENU will be displayed.

**2** Press **[▼]**, and then press the **[ENTER]** key.

- "DROP.POScorrect" will be selected.

**3** Press the **[ENTER]** key.

- Printing of the Drop position correct printed pattern will start.
- Multiple test patterns are printed. (The printed patterns are called Pattern 1, Pattern 2, Pattern 3... in the order of printing.)

**4** Press **[▲]****[▼]** to enter a correction value of Pattern 1, and then press the **[ENTER]** key.

- Corrected feeding rate: -40 to 40
- Check the test patterns. The position where an outward feeding line and a return feeding line become one straight line is the correction value.
- When the correction value is not between -40 and 40, adjust the height of the printing heads and then perform the operations in Step 2 and later.

**5** In the same way as in Step 4, enter a correction value of Pattern 2 and later, and then press the **[ENTER]** key.

**6** Press the **[END/POWER]** key several times to end the setting.

# Printing Data

## Starting a Printing Operation

**Important!**

- When using a roll media, rewind the media by hand before printing so that it is not loose. When the roll media has not been rewound tightly, it may cause the image quality to deteriorate.

### 1 Setting a Media (P.2-4)

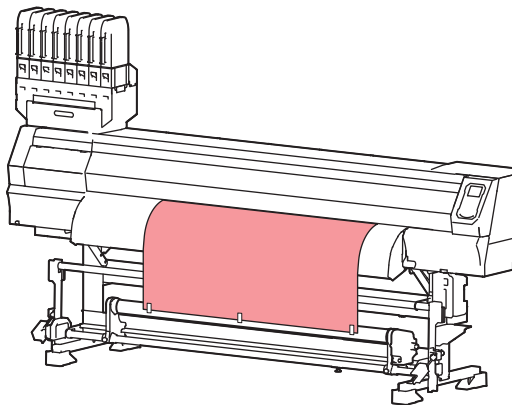

### 2 Press **FUNC3** (REMOTE) in LOCAL.

- The screen changes to REMOTE, and data can be received from the PC.

### 3 Transmit data to be printed from the PC.

- The status indicator lamp blinks and the printing conditions are displayed.
- For the method of data transmission, see the instruction manual for the output software.

Resolution : 360 /540 /720 /1080 DPI

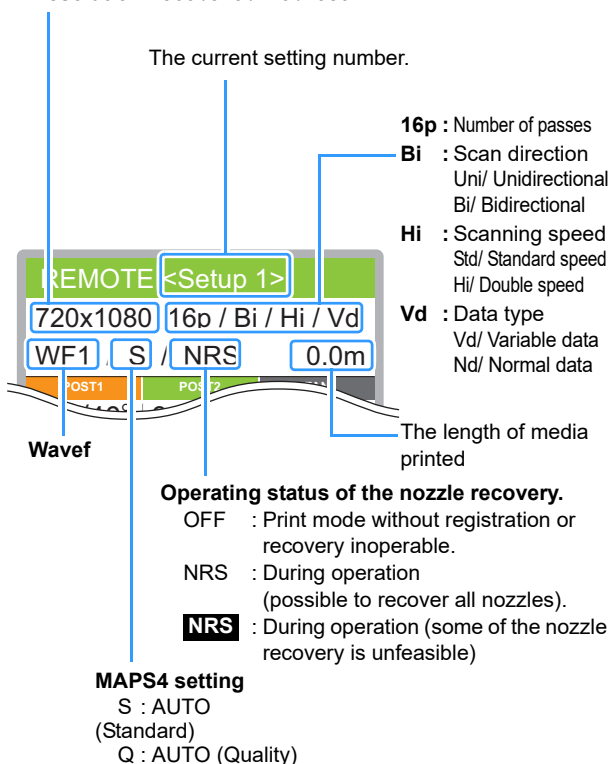

### 4 Start printing.

- The printing speed may change, depending on the width of the set media or the position of the print origin even when the same data is printed. This is because of a difference in resolution.

## Stopping a Printing Operation

Perform the following operation when stopping a printing operation halfway.

### 1 Press the **FUNC3** (LOCAL) during printing.

- The printing operation stops.
- Interrupt data sending at the PC side during the data is sent from the PC.
- Printing restarts from the interrupted data by repressing the [REMOTE] key.

## Deleting Received Data (Data Clear)

When you want to stop printing, delete the already received data.

### 1 Press the **SEL** key, and then press the **FUNC3** (DATA CLEAR) in LOCAL.

### 2 Press the **ENTER** key.

- The received data is erased then it returns to the Local.

## Behavior after printing has been completed

### Drying Feed

If set "DRYING FEED" in the MACHINE SETUP to other than "OFF," after completing the print, it will start the feed operation in order for the print surface to be dried by the optional heater unit 1800 or external heater.

- Perform the feeding operation until the back edge of printing passes the heater.
- When you press the [END] key, the operation is terminated.
- When the machine has been received next data continuously, it will operate after the last data is received.

### Screen display during drying feeding



## Cutting a media

By using the keys on the operation panel, you can cut the media at any position.

### 1 In Local, Press .

- It enters into the origin setting mode.
- By pressing [**▼**], feed the media to the cutting position.

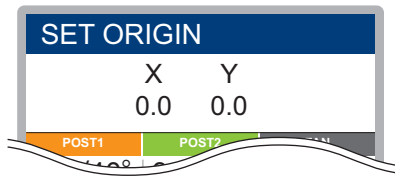

### 2 Press the key.

- The media is cut.
- When the cutting has been completed, the current mode returns to LOCAL.

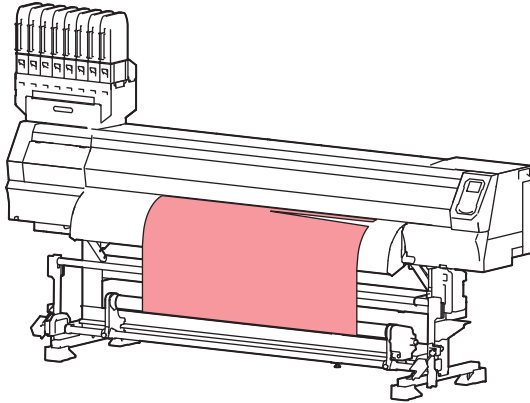



# Chapter 3

## Setup



### This chapter

describes the various setting of this machine.

About SETUP MENU .....	3-2	Setting the Display of Media Residual .....	3-17
SETUP MENU table .....	3-3	Setting the PG Drop Adjust.....	3-17
Register the optimal print conditions to match the use .....	3-4	Setting the Media Detection.....	3-17
Setting of Media Correction.....	3-5	Setting the Drying Feed.....	3-18
If the Positions of Dots Shift.....	3-6	Setting a LANGUAGE.....	3-18
Setting the HEATER .....	3-6	Setting Time.....	3-18
Setting the Optional heater .....	3-7	Setting Unit (Temperature/ Length) .....	3-18
Setting of Logical Seek .....	3-7	Setting a KEY BUZZER.....	3-19
Setting of Overprint .....	3-8	Setting the VIEW FEED.....	3-19
Setting of Drying Time.....	3-8	Setting the amount of blank space between printed lines .....	3-19
Setting of Left and Right Margins.....	3-8	Setting the SPACE FEED MODE .....	3-19
Setting of Refresh .....	3-9	Set the network.....	3-20
Setting of Vacuum Fan.....	3-9	Setting event mail function.....	3-20
Setting of Feed Speed .....	3-9	Initializing the Settings .....	3-24
Setting of Feed Quality.....	3-9	About NOZZLE CHECK MENU .....	3-25
Setting of MAPS4.....	3-10	INFORMATION MENU table .....	3-25
Setting Auto Cleaning .....	3-11	Printing Check Flow.....	3-26
Setting Interval wiping .....	3-11	Printing Operations at “Nozzle Missing” Judgment and Error Occurrence .....	3-26
Setting External heater.....	3-12	Setting the Printing Check .....	3-27
Setting Pre-feed .....	3-12	Setting the NOZZLE RECOVERY .....	3-27
About MACHINE SETUP MENU .....	3-13	Setting the Judgment Condition.....	3-27
MACHINE SETUP MENU table .....	3-14	About INFORMATION MENU .....	3-28
Setting a AUTO Power-off.....	3-16	INFORMATION MENU table .....	3-28
Setting Take-up unit .....	3-16	Displaying the Information .....	3-29
Setting Top Blower.....	3-16		

# About SETUP MENU

On SETUP MENU, you can set the print conditions to match the media you usually use.

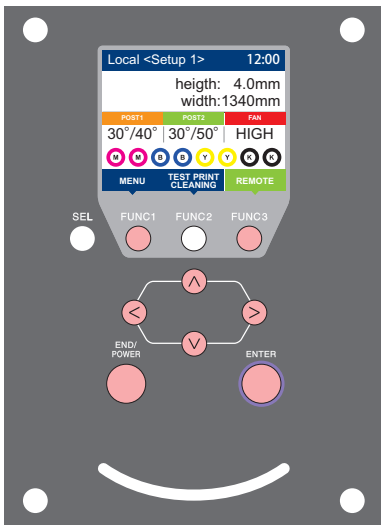

- FUNC1** : Press this to select SETUP MENU, or to switch to the previous screen.
- FUNC3** : Press this to switch to the next screen.
- ▲ ▼** : Use these to select a setting item.
- ENTER** : Press this to confirm a setting, etc..

## ◆ SETUP MENUs at-a-glance

Select "SETUP 1 to 4" or "Temporary", and then press the **ENTER** key.

**FUNC1** **FUNC3** **FUNC1** **FUNC3** **FUNC1** **FUNC3** **FUNC1** **FUNC3** **FUNC1** **FUNC3** **FUNC1** **FUNC3** **FUNC1** **FUNC3**

## SETUP MENU table



- For each setting item below, you can set it so that the machine may operate according to the value specified when you printed from your RIP software in the connected host PC.
- **Set Item** : LOGICAL SEEK/ Overprint/ DRYING TIME/ MARGIN (LEFT and RIGHT)/ VACUUM FAN/ FEED SPEED
- When you operate the machine according to the contents specified with the RIP software, set each item to "Host" when registering this machine type. When you set it other than "Host", the machine operates according to the machine setup.
- For the specifying method with the RIP software, refer to the operation manual of the RIP software.

Function name		Set value	When no instruction from RIP exists *1	Outline
FEED COMP. (P.3-5)		-9999 to 0 to 9999	_____	Used to print a pattern for correcting a media-feeding rate and correct it.
DROP.POScorrect (P.3-6)		-40.0 to 0 to 40.0	_____	Used to adjust the dot position in go and return printing.
HEATER (P.3-6)	POST1	20 to 50 °C (68 to 122°F)/OFF	_____	Sets each heater's conditions.
	POST2	20 to 60 °C (68 to 140°F)/OFF		
	OFF TIME	NONE/ 0 to 90 min		
OPTION HEATER (P.3-7)	FAN HEATER	OFF/ LOW/ MID/ HIGH	_____	Sets the heater intensity.
	STANDBY TIME	none/ 0 to 90 min.		Sets the time required for the intensity to start dropping to "LOW" after the printing operation is completed.
	OFF TIME	none/ 0 to 90 min.		Set the time from the print completion until the heater to be OFF.
LOGICAL SEEK (P.3-7)		HOST/ON / OFF	OFF	Sets the scan movable area during printing.
Overprint (P.3-8)		HOST/ 1 to 9	1	Sets the number of layers in which ink is to be applied.
DRYING TIME (P.3-8)	SCAN	HOST/ 0.0 to 9.9 sec	0 sec	Sets the time to wait for ink drying.
	PRINT END	HOST/ 0 to 120 min	0 min	
MARGIN/LEFT (P.3-8)	HOST/ -10 to 85 mm		0 mm	Sets a non-printing area along the right and left edges of the media.
MARGIN/RIGHT (P.3-8)			0 mm	
REFRESH (P.3-9)		Lv. 0~Lv. 3	_____	Set the flushing action to be performed during printing.
VACUUM (P.3-9)		HOST/ WEAK/ STANDARD/ STRONG	STRONG	Sets the absorbability of the media.
FEED SPEED *2 (P.3-9)		HOST/ 10 to 200 %	100 %	Changes the media feeding speed in printing.
FEED QUALITY (P.3-9)		HOST/ STANDARD/ QUALITY	STANDARD	Change the speed and acceleration to feed a media during printing.
AUTO CLEANING (P.3-11)	OFF, FILE, LENGTH, TIME		_____	Sets the automatic cleaning operation for the head performed before printing or during printing.
	FILE INTERVAL	1 to 1000	_____	
	TYPE	NORMAL/ SOFT/ HARD	_____	
	LENGTH INTERVAL	0.1 to 100.0m	_____	
	TYPE	NORMAL/ SOFT/ HARD	_____	
	TIME INTERVAL	10 to 120 min	_____	
	TYPE	NORMAL/ SOFT/ HARD	_____	
Cleaning Check		ON/ OFF	_____	Set to run or not a nozzle check after auto cleaning.
INTERVAL WIPING (P.3-11)		3 to 255 min, OFF	_____	Sets the wiping operation performed after printing is completed.
EXTERNAL HEATER (P.3-12)		ON/ OFF	_____	Used to set external heater to ON/OFF.
MAPS4 (P.3-10)	AUTO	MAPS MODE	STANDARD/ QUALITY	Perform setting to reduce stripes between passes.
	MANUAL	SPEED	50 to 100%	
		Smoothing Lv.	0 to 25 to 100%	
Pre-feed (P.3-12)		OFF/ 100 to 500 mm	_____	In order to prevent sticking and wrinkles of the media, set the media length to feed back and forth before printing.
RESET SETTING (P.3-5)		The configuration in the settings 1-4 can be reset individually.		

\*1. This is the setting value to be used for printing when setting value is not specified at the RIP software (host) side, or, you give priority to the setting value at the machine side.

\*2. When you set this to "100%" or more, required time for completion of printing will be shortened. However, enough drying time cannot be ensured and it may affect the image quality.

## Register the optimal print conditions to match the use

In this machine, you will be able to register print conditions, SETUP 1 to 4 individually to match the media in advance.

For example, after print on different types of media, return to the media always use. In such case you can set the optimum printing conditions by simply selecting the registered SETUP 1 to 4.



- Print conditions that can be pre-registered with the machine are the four types, "SETUP 1" to "SETUP 4".
- If you print with the print condition which do not often use, you will be able to set the print conditions by selecting "Temporary".  
If turn on the power again, settings in "Temporary" will return to the original state when it was purchased.  
Also if turn on the power again in "Temporary" state, it will be the state in selecting "SETUP 1".

### Register the print conditions to SETUP 1 to 4

- 1 Press **FUNC1** (MENU) → **ENTER** in LOCAL.
- 2 Press **▲** **▼** to select SETUP 1 to 4, and press the **ENTER** key.
  - The item selected indicates ● and others show ○.
  - SETUP MENU will be displayed.
- 3 Press **▲** **▼** to select and set each item in the setup menu list.
  - Please see the reference page in the setup menu list for detailed configuration procedure.

### How to use [Temporary]

[Temporary] is not only to set the print condition to be used only once, but also can be used for partial change of the registered SETUP "1 to 4", or for reflecting the print conditions set by the [Temporary] to SETUP 1 to 4.

#### ● Register the print conditions in [Temporary]

Registration of the print conditions to [Temporary] can be done as the same method as to SETUP 1 to 4.

- 1 Press **FUNC1** (MENU) → **ENTER** in LOCAL.
- 2 Press **▲** **▼** to select "Temporary", and press the **ENTER** key.
  - SETUP MENU will be displayed.
- 3 Press **▲** **▼** to select and set each item in the setup menu list.
  - Please see the reference page in the setup menu list for detailed configuration procedure.

#### ● Copy the contents of SETUP 1 to 4 to [Temporary]

You can use it with changing the part of registration contents of SETUP 1 to 4.

Select "copy" from the registration screen of [Temporary], and specify the copy source (SETUP 1 to 4).

- 1 Press **FUNC1** (MENU) → **ENTER** in LOCAL.
- 2 Press **▲** **▼** to select "Temporary", and press the **ENTER** key.
  - SETUP MENU will be displayed.
- 3 Press **FUNC1** (<<).
- 4 Press **▲** **▼** to select "COPY", and press the **ENTER** key.
  - Selection screen of the copy source will be displayed.
- 5 Press **▲** **▼** to SELECT the copy source (SETUP 1 to 4) and press the **ENTER** key.
  - Confirmation screen of the copy will be displayed.
- 6 Press the **ENTER** key.
  - Settings selected in step 5 is copied to Temporary.
- 7 Press **▲** **▼** to select the setting item to be changed, and press the **ENTER** key.
  - Please see the reference page in the setup menu list for detailed configuration procedure.

#### ● Reflect The Content Set In [Temporary] To Setup 1 To 4

- 1 Press **FUNC1** (MENU) → **ENTER** in LOCAL.
- 2 Press **▲** **▼** to select "Temporary", and press the **ENTER** key.
  - SETUP MENU will be displayed.
- 3 Press **▲** **▼** to select and set each item in the setup menu list.
  - Please see the reference page in the setup menu list for detailed configuration procedure.
- 4 Display the last page of Temporary and select "SAVE SETTING", and press the **ENTER** key.
  - Selection screen of the save location will be displayed.
- 5 Press **▲** **▼** to select the location selected (SETUP 1 to 4), and press the **ENTER** key.
  - Save confirmation screen will be displayed.

- 6** Press the **ENTER** key.
- Settings of Temporary will be saved to the location selected in step 5.

- 7** Press the **END/POWER** key several times to end the setting.

## Reset the registered contents

Reset the contents registered to SETUP 1 to 4.

- 1** Press **FUNC1** (MENU) → **ENTER** in LOCAL.

- 2** Press **▲▼** to select SETUP 1 to 4 to be reset and press the **ENTER** key.
- SETUP MENU will be displayed.

- 3** Press **FUNC1** (<<).

- 4** Press **▲▼** to select “RESET SETTING”, and press the **ENTER** key.
- Confirmation screen of reset settings will be displayed.

- 5** Press the **END/POWER** key several times to end the setting.

## Setting of Media Correction

Correct the media feed amount to match the type of media you are using.

If the correction value is not appropriate, stripes may appear on the printed image, thus resulting in a poor printing.



- On completion of [MEDIA COMP.] during use of a roll media, the media returns to the printing origin. Then the roll media in the rear of this machine will slacken. Before printing, take up the slack in the roll media by hand; a loose roll media can result in an inferior image quality.
- When printing with a take-up device, set the media first and then perform media correction.

A pattern for media correction is printed and a media-feeding rate is corrected.



- Two bands are printed in the correction pattern.
- Make adjustment so that an even color density is obtained in the boundary between the two bands.

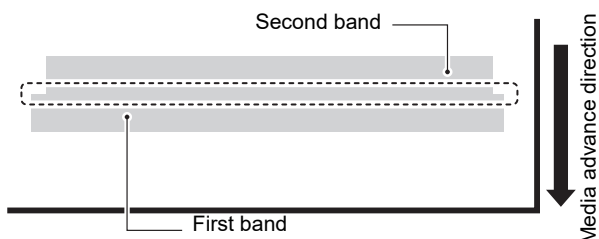

- 1** Set a media. (☞ P.2-4)

- 2** Press **FUNC1** (MENU) → **ENTER** in LOCAL.

- 3** Press **▲▼** to select SETUP 1 to 4, and press the **ENTER** key.
- SETUP MENU will be displayed.

- 4** Press **▲▼** to select “FEED COMP”, and press the **ENTER** key.

- 5** Press the **ENTER** key twice to print a correction pattern.

- 6** Check the correction pattern and enter a correction value.

- A screen for entering the correction value will be displayed.
- Enter a correction value in "+":  
The boundary between the two bands is widened.
- Enter a correction value in "-":  
The boundary between the two bands is narrowed.
- When you change the correction value by "30", the width of the boundary changes by about 0.1 mm.

- 7** Press the **ENTER** key.

- Print a correction pattern again and check it.
- When media correction is needed, perform the operation in Step 7 to make correction.

- 8** Press the **END/POWER** key several times to end the setting.

## Correcting Media-feeding during Printing

A media-feeding rate can be corrected even in the remote mode or when image data is printed.

- 1** Press **FUNC1** (ADJUST) → **ENTER** in the Remote.

- 2** Press **▲▼** to enter a corrected feeding rate.

- Corrected feeding rate: -9999 to 9999
- The value entered here is reflected in the corrected feeding rate soon.

- 3** Press the **ENTER** key twice .

- key. The changed value is registered.
- When you press the [ENTER] key instead of the [END] key, the value entered here will be valid temporarily. (When you perform media detection again or turn the power OFF, the correction value is cleared.)

## If the Positions of Dots Shift...

When the condition for printing (media thickness/ink type/ etc.) has been changed, perform the following operation to correct the ink drop position for bidirectional (Bi) printing and obtain the proper printing result.

### Example of a Printed Pattern

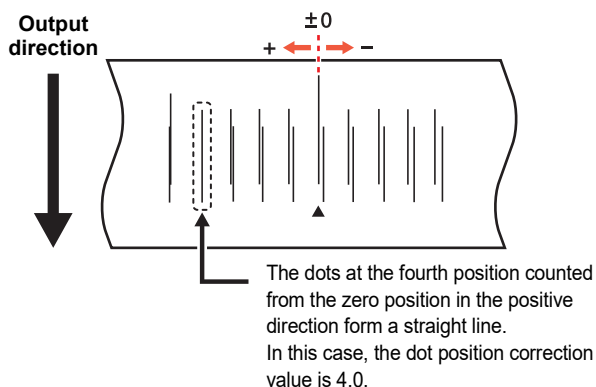

- 1** Set a media on the machine. (P.2-4)
  - In order to print a pattern, a media that is 500 mm wide at least is necessary.
- 2** Press **FUNC1** (MENU) → **ENTER** in LOCAL.
- 3** Press **▲▼** to select **SETUP 1 to 4**, and press the **ENTER** key.
  - SETUP MENU will be displayed.
- 4** Press **▲▼** to select “**DROP.POS correct**”, and press the **ENTER** key.
- 5** Press the **ENTER** key.
  - Start the pattern printing.
  - Multiple test patterns are printed. (The printed patterns are called Pattern 1, Pattern 2, Pattern 3... in the order of printing.)
- 6** Press **▲▼** to enter a correction value of **Pattern 1**, and press the **ENTER** key.
  - Corrected feeding rate: -40 to 40
  - Check the test patterns. The position where an outward feeding line and a return feeding line become one straight line is the correction value.
  - When the correction value is not between -40 and 40, adjust the height of the printing heads and then perform the operations in Step 2 and later.
- 7** In the same way as in Step 4, enter a correction value of **Pattern 2** and later, and press the **ENTER** key.
- 8** Press the **END/POWER** key several times to end the setting.

## Setting the HEATER

Post-heater 1 and Post-heater 2 are equipped on the platen.

Type of HEATER	Function
POST1	Dries ink after printing.
POST2	

Here, in addition to the temperature setting of each heater, the time from the print completion until the heater to be OFF can be set up.

- 1** Press **FUNC1** (MENU) → **ENTER** in LOCAL.
- 2** Press **▲▼** to select **SETUP 1 to 4**, and press the **ENTER** key.
  - SETUP MENU will be displayed.
- 3** Press **▲▼** to select “**HEATER**”, and press the **ENTER** key.
- 4** Set each heater temperature by pressing **▲▼**.
  - **Heater selecting** : Select by **▲▼** and press the **ENTER** key
  - **Temperature setting** : Set by **▲▼**
  - Temperature setting of each heater
    - POST 1: 20 ~ 50°C
    - POST 2: 20 ~ 60°C
- 5** Press **▲▼** to select “**OFFTIME**”, and press the **ENTER** key.
- 6** Press **▲▼**, set the time until the heater to be OFF after printing, and press the **ENTER** key.
  - Set value: NONE/ 0 to 90 min
- 7** Press the **END/POWER** key several times to end the setting.

## Setting the Optional heater

For details about the optional drying heater, refer to the separate document, "OPT-J0388 Heater 1800 Operation Manual."

- 1 Press **FUNC1 (MENU)** → **ENTER** in LOCAL.
- 2 Press **▲▼** to select **SETUP 1 to 4**, and press the **ENTER** key.
  - SETUP MENU will be displayed.
- 3 Press **▲▼** to select **"OPTION HEATER"**, and press the **ENTER** key.
  - "OPTION HEATER" is indicated only when the optional heater unit is connected.
- 4 Press **▲▼** to select **"FAN HEATER"**, and press the **ENTER** key.
- 5 Press **▲▼** to select the power of heater, and press the **ENTER** key.
  - Set value: OFF/LOW/MID/HIGH
  - Heating of the heater starts by selecting any set other than "OFF".
- 6 Press **▲▼** to select **"STANDBY TIME"**, and press the **ENTER** key.
- 7 Press **▲▼** to set the standby time, and press the **ENTER** key.
  - Set value: none, 0 to 90 inutes
  - Set the time from the end of printing to the start of decreasing of the heater unit to "LOW" status.
  - When receiving a print data while the temperature was down, the printing will start automatically after the temperature goes up to the pre-set value.
  - If setting the value as "none", the heater will not go down to "LOW".
- 8 Press **▲▼** to select **"OFFTIME"**, and press the **ENTER** key.
- 9 Press **▲▼**, set the time until the heater to be OFF after printing, and press the **ENTER** key.
  - Set value: none, 0 to 90 inutes
  - If the "STANDBY TIME" has been set in step 7, the heater will be turned OFF after erapsing "STANDBY TIME and the time set here."
- 10 Press the **END/POWER** key several times to end the setting.

## Setting of Logical Seek

The head's operation varies depending on the LOGICAL SEEK settings, as shown in the figure below.

### Movement of heads when LOGICAL seek is OFF

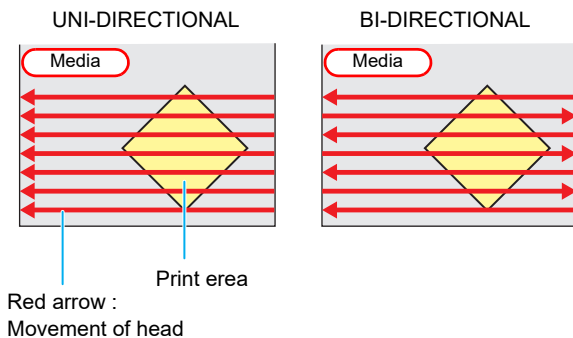

### Movement of heads when LOGICAL seek is ON

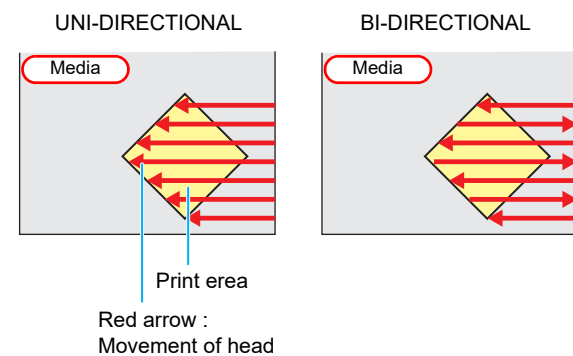

- 1 Press **FUNC1 (MENU)** → **ENTER** in LOCAL.
- 2 Press **▲▼** to select **SETUP 1 to 4**, and press the **ENTER** key.
  - SETUP MENU will be displayed.
- 3 Press **▲▼** to select **"LOGICAL SEEK"**, and press the **ENTER** key.
- 4 Press **▲▼** to select a set value, and press the **ENTER** key.
  - Set value : HOST / ON / OFF
- 5 Press the **END/POWER** key several times to end the setting.

## Setting of Overprint

Sets the number of layers in which ink is to be applied.

- 1 Press **FUNC1** (MENU) → **ENTER** in LOCAL.
- 2 Press **▲▼** to select SETUP 1 to 4, and press the **ENTER** key.
  - SETUP MENU will be displayed.
- 3 Press **FUNC3** (>>) .
- 4 Press **▲▼** to select “Overprint” , and press the **ENTER** key.
- 5 Press **▲▼** to set number of Overprint, and press the **ENTER** key.
  - Setting value : Host/ 1 to 9 times
- 6 Press the **END/POWER** key several times to end the setting.

## Setting of Drying Time

In the drying time setting, the following items for ink drying time are set.

- **SCAN** : Ink drying time for each scanning is set. (During bidirectional printing, the machine stops for a certain period of time specified for each of the outward and return scanning.)
- **PRINT END** : Ink drying time after printing has been complete is set.

- Important!**
- When you give priority to the setting at the RasterLink side, make the setting value “Host”.
  - “SCAN” set in this machine is displayed as “Pause Time per Scan” in the RasterLink.
  - You cannot specify the print end at the RasterLink side. When you set this machine to “Host”, printing will be performed in “PRINT END= 0 min.” status.

- 1 Press **FUNC1** (MENU) → **ENTER** in LOCAL.
- 2 Press **▲▼** to select SETUP 1 to 4, and press the **ENTER** key.
  - SETUP MENU will be displayed.
- 3 Press **FUNC3** (>>) .
- 4 Press **▲▼** to select “DRYING TIME”, and press the **ENTER** key.
- 5 Press the **ENTER** key.

- 6 Press **▲▼◀▶** to set drying time, and press the **ENTER** key.

- Set the drying time for canning and after printing is completed. To enable the drying time specified in your RIP, select “Host”.
- **Scanning setting value** : Host or 0.0 sec. to 9.9 sec.
- **Print end setting value**: Host or 0 sec. to 120 inutes.
- **Item selecting** : by the **▲▼** keys
- **Time setting** : by the **◀▶** keys

- 7 Press the **END/POWER** key several times to end the setting.

## Setting of Left and Right Margins

Set a non-printing area along the left and right edges of the media.

The offset value against the standard margin 15 mm is set hereupon.

- Important!**
- When you give priority to the setting at the RIP software side, make the setting value “Host”.
  - You cannot specify the margins at the attached RIP software (RasterLink). When you use the RasterLink, if you set this machine to “Host”, printing will be performed in “Margins for right and left off set value= 0 mm” status.
  - The margin setting is reflected when the media width is detected.

- 1 Press **FUNC1** (MENU) → **ENTER** in LOCAL.
- 2 Press **▲▼** to select SETUP 1 to 4, and press the **ENTER** key.
  - SETUP MENU will be displayed.
- 3 Press **FUNC3** (>>) .
- 4 Press **▲▼** to select “Margin/L” or “Margin/R”, and press the **ENTER** key.
- 5 Press **▲▼** to select a set value, and press the **ENTER** key.
  - Set value : HOST / -10 to 85 mm
- 6 Press the **END/POWER** key several times to end the setting.



- Pay attention to that printing may start on the media press if a right and left margin is set to 5 mm or less when the media press is used in printing.



## Setting of Refresh

Set the amount of refresh ink ejected during printing. Every time you raise the level, the discharge amount will increase.

- 1 Press **FUNC1** (MENU) → **ENTER** in LOCAL.
- 2 Press **▲▼** to select SETUP 1 to 4, and press the **ENTER** key.
  - SETUP MENU will be displayed.
- 3 Press **FUNC3** (>>).
- 4 Press **▲▼** to select “REFRESH”, and press the **ENTER** key.
- 5 Press **▲▼** to select a set value, and press the **ENTER** key.
  - Set value : Lv. 0~Lv. 3
- 6 Press the **END/POWER** key several times to end the setting.

## Setting of Vacuum Fan

Sets the absorbability of the media. By setting the absorption power to match the media, you can prevent print errors due to media rise-up.

- 1 Press **FUNC1** (MENU) → **ENTER** in LOCAL.
- 2 Press **▲▼** to select SETUP 1 to 4, and press the **ENTER** key.
  - SETUP MENU will be displayed.
- 3 Press **FUNC3** (>>).
- 4 Press **▲▼** to select “VACUUM FAN”, and press the **ENTER** key.
- 5 Press **▲▼** to select a set value, and press the **ENTER** key.
  - Set value : HOST/WEAK /STANDARD/ STRONG
- 6 press the **END/POWER** key several times to end the setting.

## Setting of Feed Speed

Changes the media feeding speed in printing.

- 1 Press **FUNC1** (MENU) → **ENTER** in LOCAL.
- 2 Press **▲▼** to select SETUP 1 to 4, and press the **ENTER** key.
  - SETUP MENU will be displayed.

- 3 Press **FUNC3** (>>) twice.

- 4 Press **▲▼** to select “FEED SPEED”, and press the **ENTER** key.

- 5 Press **▲▼** to select a set value, and press the **ENTER** key.
  - Set value : HOST / 10 to 200%

- 6 Press the **END/POWER** key several times to end the setting.

- Important!**
- Some speed is not changed according to a setting condition.
  - The media feed speed during printing is decided by this setting and the set value in [Setting of Feed Quality].

## Setting of Feed Quality

Change the speed and acceleration to feed a media during printing. If the media feed is not stable, change the setting into [QUALITY] may improve the situation.

Action will be changed as follows according to a setting.

- STANDARD : The media feed is done with the default value of the speed and acceleration.
- QUALITY : The media feed is done with the speed and acceleration slower than the default setting value.

- 1 Press **FUNC1** (MENU) → **ENTER** in LOCAL.

- 2 Press **▲▼** to select SETUP 1 to 4, and press the **ENTER** key.
  - SETUP MENU will be displayed.

- 3 Press **FUNC3** (>>) twice.

- 4 Press **▲▼** to select “FEED QUALITY”, and press the **ENTER** key.

- 5 Press **▲▼** to select a set value, and press the **ENTER** key.
  - Set value:HOST / STANDARD / QUALITY

- 6 Press the **END/POWER** key several times to end the setting.

- Important!**
- The media feed speed during printing is decided by this setting and the set value in [Setting of Feed Speed].

## Setting of MAPS4

The MAPS (Mimaki Advanced PassSystem) function to disperse the pass boundary to make the feeding stripes less visible.



- Changing the MAPS4 settings may change the color tone. Check the effects before use.
- MAPS may not be effective depending on image to be printed. Use it after checking effect in advance.

### ● Conditions disabling MAPS function

The MAPS function may be disabled under the following conditions. In addition, the MAPS may not be effective, depending on the image to be printed.

#### 4-colors ink set

Resolution	Pass	Scan speed	MAPS MODE
360x 360	1 pass	Normal speed	Standard
540x 360	2 pass	High speed	
720x 720	4 pass	High speed	
720x 1080	6 pass	High speed	

#### 6-colors, 7-colors, 8-colors ink set

Resolution	Pass	Scan speed	MAPS MODE
360x 360	2 pass	Normal speed	Standard
540x 360	4 pass	High speed	
720x 720	8 pass	High speed	
720x 1080	12 pass	High speed	

## Setting MAPS4 Function (AUTO)

**1** Press **FUNC1** (MENU) → **ENTER** in LOCAL.

**2** Press **▲▼** to select **SETUP 1 to 4**, and press the **ENTER** key.

- SETUP MENU will be displayed.

**3** Press **FUNC3** (>>) twice.

**4** Press **▲▼** to select **"MAPS4"**, and press the **ENTER** key.

**5** Press **▲▼** to select **"AUTO"**, and press the **ENTER** key.

- To select "MANUAL" for the setting, refer to P.3-10 "Setting MAPS4 Function (MANUAL)".

**6** Press **▲▼** to select the **"MAPS MODE"**, and press the **ENTER** key.

**7** Press **▲▼** to select the setting value (**STANDARD/QUALITY**), and press the **ENTER** key.

**STANDARD** : Prints in standard quality mode.?

**QUALITY** : Prints in high quality mode.

"Prints more slowly than when "STANDARD" is selected.

**8** Press the **END/POWER** key several times to end the setting.

## Setting MAPS4 Function (MANUAL)

**1** Press **FUNC1** (MENU) → **ENTER** in LOCAL.

**2** Press **▲▼** to select **SETUP 1 to 4**, and press the **ENTER** key.

- SETUP MENU will be displayed.

**3** Press **FUNC3** (>>) twice.

**4** Press **▲▼** to select **"MAPS4"**, and press the **ENTER** key.

**5** Press **▲▼** to select **"MANUAL"**, and press the **ENTER** key.

- To select "AUTO" for the setting, refer to P.3-10 "Setting MAPS4 Function (AUTO)".

**6** Press **▲▼** to select the **"SPEED" (50 to 100%)**, and press the **ENTER** key.

- Select a speed for printing. By using standard quality printing as reference, set in the direction of minus (-) to decrease the print speed, and set in the direction of plus (+) to increase the print speed.

**Important!**

- If the speed is changed, **NOZZLE RECOVERY** (☞ P.3-27) may not become effective. Check in advance before use.

**7** Press **▲▼** to select the **"Smoothing Lv."**, and press the **ENTER** key.

**8** Press **▲▼** to change the smoothing level, and press the **ENTER** key.

- Set Value : 0 to 100% (set in units of 5%)
- The MAPS4 effect become strong as the set value increase, and become weak as the set value decrease.

**9** Press the **END/POWER** key several times to end the setting.

## Setting Auto Cleaning

You can set the machine so that it counts the number of printed files or the length or time after printing has been completed, and performs cleaning automatically if required. You can select the auto cleaning setting from three types below:

- **PAGE** : Set the cleaning intervals by the number of printed files.
- **LENGTH** : Set the cleaning intervals by the printed length.
- **TIME** : Set the cleaning intervals by the printed time.

Besides, automatic nozzle check after auto cleaning can be set. (Cleaning Check function)

The machine can perform a stable printing operation with its heads always kept clean.

**1** Press **FUNC1** (MENU) → **ENTER** in LOCAL.

**2** Press **▲** **▼** to select **SETUP 1 to 4**, and press the **ENTER** key.

- SETUP MENU will be displayed.

**3** Press **FUNC3** (>>) twice.

**4** Press **▲** **▼** to select “**AUTO CLEANING**”, and press the **ENTER** key.

**5** Press the **ENTER** key, and press **▲** **▼** to select the type of auto cleaning.

- There are “PAGE”, “LENGTH” and “TIME” for auto cleaning.

**FILE** : When the set number of prints has been completed, the machine performs head cleaning automatically.

**LENGTH** : When the set length has passed, the machine performs head cleaning automatically.

**TIME** : When the set time has passed, the machine performs head cleaning automatically.

- If you do not set auto cleaning, first select “OFF” and then proceed to the Step 6.

**6** Press **ENTER** , and press **▲** **▼** to select the cleaning interval.

- Depending on the auto cleaning type selected in the Step 3, the setting value differs.

For **FILE** : 1 to 1000 file

For **LENGTH** : 0.1 to 100.0m (in 0.1m increment)

For **TIME** : 10 to 120min (in 10min increment)

**7** Press the **ENTER** key, and press **▲** **▼** to select the cleaning type.

- Set Value : NORMAL/ SOFT/HARD

**8** Press the **ENTER** key, and press **▲** **▼** to select “Cleaning Check”.

**9** Press the **ENTER** key, and press **▲** **▼** to select set value.

- Set Value : ON/ OFF

**10** Press the **ENTER** key .

**11** Press the **END/POWER** key several times to end the setting.

**Important!**

- Depending on the state of the heads, etc., the image quality deterioration may not be improved even with this function performed. In this case, contact our service office or the distributor in your region.

## Setting Interval wiping

When the set time has passed, nozzle face of the head is cleaned automatically to remove ink droplets on the nozzle face.

In case that deflection, nozzle missing, or symptom which ink droplets fall down occurred, set the interval between each operation shorter.

**1** Press **FUNC1** (MENU) → **ENTER** in LOCAL.

**2** Press **▲** **▼** to select **SETUP 1 to 4**, and press the **ENTER** key.

- SETUP MENU will be displayed.

**3** Press **FUNC3** (>>) twice.

**4** Press **▲** **▼** to select “**INTERVAL WIPING**”, and press the **ENTER** key.

**5** Press **▲** **▼** to set intervals.

- Set Value : 3 to 255 Minutes, OFF
- When [OFF] is set, periodical wiping is not executed.

**6** Press the **ENTER** key.

**7** Press the **END/POWER** key several times to end the setting.

## Setting External heater

Used to set external heater to ON/OFF.

- 1 Press **FUNC1** (MENU) → **ENTER** in LOCAL.
- 2 Press **▲** **▼** to select SETUP 1 to 4, and press the **ENTER** key.
  - SETUP MENU will be displayed.
- 3 Press **FUNC1** (<<).
- 4 Press **▲** **▼** to select “EXTERNAL HEATER”, and press the **ENTER** key.
- 5 Press **▲** **▼** to select set value.
  - Set Value: ON/OFF
- 6 Press the **ENTER** key.
- 7 Press the **END/POWER** key several times to end the setting.

## Setting Pre-feed

The following effects can be expected by feeding back and forth the media before printing.

- Prevent media from sticking to the various rollers and the platen of this machine.
- If the wrinkle is shifted to the media, wrinkle reduction can be expected.

- 1 Press **FUNC1** (MENU) → **ENTER** in LOCAL.
- 2 Press **▲** **▼** to select SETUP 1 to 4, and press the **ENTER** key.
  - SETUP MENU will be displayed.
- 3 Press **FUNC3** (>>) twice.
- 4 Press **▲** **▼** to select “Pre-Feed”, and press the **ENTER** key.
- 5 Press **▲** **▼** to set the feeding media lengths.
  - Set Value : OFF, 100 to 500 mm
  - When [OFF] is set, pre-feed is not executed.
- 6 Press the **ENTER** key.
- 7 Press the **END/POWER** key several times to end the setting.

# About MACHINE SETUP MENU

Common settings are functions for using this machine easily.  
The following items can be set in machine setups.

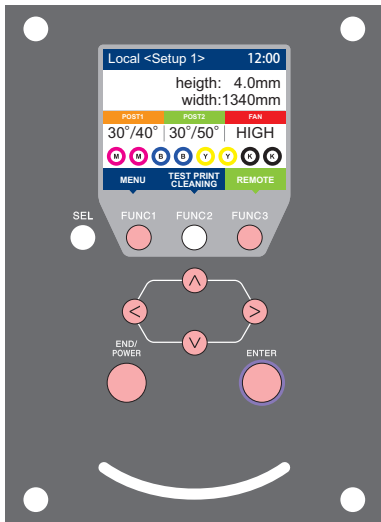

**FUNC1** : Press this to select MACHINE SETUP MENU, or to switch to the previous screen.

**FUNC3** : Press this to switch to the next screen.

**▲ ▼** : Use these to select a setting item.

**ENTER** : Press this to confirm a setting, etc..

## ◆ MACHINE SETUP MENUS at-a-glance

**FUNC1** + **▼** Two times

**FUNC1**

**FUNC3**

**FUNC1**

**FUNC3**

**FUNC1**

**FUNC3**

**FUNC1**

**FUNC3**

**FUNC1**

**FUNC3**

**FUNC1**

**FUNC3**

## MACHINE SETUP MENU table

Function name		Set value	Default	Meaning
AUTO Power-off (☞ P.3-16)		NONE/ 10 ~ 600min	30min	When no operation has been performed for the set time, the power supply is automatically turned "OFF".
TAKE-UP UNIT (☞ P.3-16)	TAKE-UP UNIT	ON/ OFF	ON	For setting whether the take-up unit is used or not used.
	TAKE-UP TENSION BAR	ON/ OFF	OFF	For setting whether the take-up tension bar is used or not used.
	TAKE-UP SW	Continuance/ Temporary	Continuance	Set the operation method when press ON / OFF button on the take-up unit.
	Detecting Take-up unit	END/START		When select "START", the operation of take-up detection will be executed.
Top blower (☞ P.3-16)	ON	AUTO/ STORONG/ WEAK	AUTO	Set the operation of the top blower in print.
	OFF			
MEDIA REMAIN (☞ P.3-17)		ON/ OFF	OFF	You can control the remaining amount of media.
HEAD HEIGHT (☞ P.2-4)		2.0 to 7.0 mm		Set the head height.
PG DROP ADJUST (☞ P.3-17)				Adjust the outward and return ink drop positions during bidirectional printing.
MEDIA DETECT (☞ P.3-17)	DETECTION TYPE	AUTO/MANUAL	AUTO	Set the media detection method.
	INPUT THICKNESS	ON/ OFF	ON	Set whether to enter the thickness of the media to be used during media detection.
DRYING FEED (☞ P.3-18)	DRYING FEED	OFF/ 100 to 1000 mm	OFF	Set the length of the media to feed after printing is complete.
	BACKWARD FEED	ON/ OFF	OFF	Set if require the back-feed after feed.
LANGUAGE (☞ P.3-18)			English	Displayed language is changed.
TIME SET (☞ P.3-18)		+4h ~ -20h	Japan time	Time difference is corrected.
UNIT/ TEMP. (☞ P.3-18)		°C (Centigrade)/°F (Fahrenheit)	°C	A unit for displaying temperature is set.
UNIT/ LENGTH (☞ P.3-18)		mm / inch	mm	A unit for displaying length and area is set.
KEY BUZZER (☞ P.3-19)		OFF / ON	ON	A buzzer sound when keys are pressed is set.
VIEW FEED (☞ P.3-19)		ON / OFF	ON	Set whether media feeding is performed for checking the result of the test printing etc. or not.
Space Btwn PP. (☞ P.3-19)		NONE / 10 to 50 mm	NONE	Sets the amount of blank space between printed lines.
SPACE FEED MODE (☞ P.3-19)		INTERMITTENT / CONTINUOUS	INTERMITTENT	Change the feed mode of the margin included in the image data.
NETWORK (☞ P.3-20)	Set the network.			
	Check IP Addr.	The IP address currently used by this machine is displayed.		
	Check MAC Addr.	The IP address currently used by this machine is displayed.		
	DHCP	ON / OFF		When it is ON, the IP address given by the DHCP server is used.
	AutoIP	ON / OFF		When it is ON, the IP address is determined by the AutoIP protocol. However, DHCP is ON, DHCP has priority.
	IP Address *1	Set the IP address used by this machine.		
	Default Gateway *1	Set the default gateway used by this machine.		
	DNS Address *1	Set the DNS server address used by this machine.		
	SubNet Mask *1	Set the digit number of the subnet mask used by this machine.		

Function name		Set value		Default	Meaning		
EVENT MAIL	Mail Delivery (P.3-20)	ON / OFF		OFF	Set whether you send/ do not send the e-mail when the set event occurs.		
	Select Event (P.3-21)	Print Start Event	ON / OFF	OFF	Set whether you send/ do not send the e-mail at the start of printing.		
		Print End Event	ON / OFF	OFF	Set whether you send/ do not send the e-mail at the end of printing.		
		Error Event	ON / OFF	OFF	Set whether you send/ do not send the e-mail when a error occurs.		
		Warning Event	ON / OFF	OFF	Set whether you send/ do not send the e-mail when a warning occurs.		
		Other Event	ON / OFF	OFF	Set whether you send/ do not send the e-mail when an event other than the above occurs.		
	Mail Address (P.3-21)	Set the e-mail address to which you send the event mail.		Alphanumeric characters and symbols (within 96 characters)			
	Message Subject (P.3-21)	Set the characters to write in the subject of the event mail.		Alphanumeric characters and symbols (within 8 characters)			
	Server Setup (P.3-22)	SMTP Address		Set the SMTP server.			
		SMTP Port No.		Set the SMTP port number.			
		SENDER ADDRESS		Set the e-mail address to be used as the sender mail address.			
		Authentication	POP before SMTP	Set the SMTP server authentication method (SMTP authentication).			
			SMTP Authentication				
			OFF				
		User Name *2		Set the user name used for the authentication.			
		Pass Word *2		Set the password used for the authentication.			
		POP3 Address *3		Set the POP server.			
APOP *3		Set ON/ OFF of APOP.					
Transmit Test (P.3-23)	Send the test e-mail.						
RESET(P.3-24)				All setting values are returned to the status default.			

\*1. Settable when both of DHCP and AutoIP are [OFF]

\*2. Settable only when Auth. is not OFF

\*3. Settable only when Auth. is POP before SMTP

## Setting a AUTO Power-off

When no operation has been performed for the set time, the power supply is automatically turned "OFF".

- 1 Press **FUNC1 (MENU)** → **▼** (twice) → **ENTER** in **LOCAL**.
  - MACHINE SETUP MENU will be displayed.
- 2 Press **▲▼** to select "AUTO POWER OFF", and press the **ENTER** key.
- 3 Press **▲▼** to select a set value, and press the **ENTER** key.
  - Set Value : none, 10 to 600min
- 4 Press the **END/POWER** key several times to end the setting.

## Setting Take-up unit

For the "TAKE-UP UNIT" settings, set the following items:

- Use take-up unit/ Do not use take-up unit.
- Use/Do not use the take-up tension bar.
- Operation when the ON/OFF switch for take-up unit is pressed.
- "START" is selected and execute the operation of take-up detection.

- 1 Press **FUNC1 (MENU)** → **▼** (twice) → **ENTER** in **LOCAL**.
  - MACHINE SETUP MENU will be displayed.
- 2 Press **▲▼** to select "TAKE-UP UNIT", and press the **ENTER** key.
- 3 Press the **ENTER** key.
  - "TAKE-UP UNIT" will be selected.
- 4 Press **▲▼** to select a set value, and press the **ENTER** key.
  - Set Value : ON/ OFF
- 5 Press **▼**, and press the **ENTER** key.
  - "TAKE-UP TENSION BAR" will be selected.
- 6 Press **▲▼** to select a set value, and press the **ENTER** key.
  - Set Value : ON/ OFF
- 7 Press **▼**, and press the **ENTER** key.
  - "TAKE-UP SW" will be selected.

- 8 Press **▲▼** to select a set value, and press the **ENTER** key.

- Set Value : Continuance/ Temporary

Continuance :

Switching ON / OFF the winding operation when pressing the switch each time. (Take-up unit in operation does not stop until press again ON / OFF switch.)

Temporary :

Do the winding operation only while holding down the switch. (When release the switch, winding operation is stopped.)

**Important!**

- If you are using a direct-connection unit, even set to "Continuance", it will automatically run the "Temporary" operation.

- 9 Press **▼** to select "Detecting Take-up unit".

- "Detecting Take-up unit" will be displayed.

- 10 Press **▶**.

- "START" is selected so execute the operation of take-up detection.

- 11 Press the **END/POWER** key several times to end the setting.

## Setting Top Blower

Set the operation of the top blower in print.

Turn the top blower setting "ON", and you can set the strength for the blower.

- 1 Press **FUNC1 (MENU)** → **▼** (twice) → **ENTER** in **LOCAL**.
  - MACHINE SETUP MENU will be displayed.
- 2 Press **▲▼** to select "Top blower", and press the **ENTER** key.
- 3 Press **▲▼** to select "ON", and press the **ENTER** key.
  - ON : You can choose the air volume of the blower.
  - OFF : The top blower does not work while printing process. Proceed to step 6.
- 4 Press **▲▼** to select "STRENGTH", and press the **ENTER** key.
- 5 Press **▲▼** to select a set value (AUTO/ STRONG/ WEAK), and press the **ENTER** key.
  - Set value : ON/ OFF
- 6 Press the **END/POWER** key several times to end the setting.



## Setting the Display of Media Residual

Whether the screen displays the remaining amount of a media is set.

<b>When the media remaining amount display is turned to "ON"</b>	the remaining amount of a media is displayed in Remote. (However, when a leaf media is used, the length of the media to be printed is displayed.)
<b>When the media remaining amount display is turned to "OFF"</b>	the remaining amount of a media is not displayed in the Remote.



- The amount of a media that has been fed by the printing and jog keys is reflected in the remaining amount of a media.
- The length of a media (initial value of the remaining amount) is entered when a roll media is detected. (P.2-9)
- The setting configured here does not become effective unless media detection is performed after the setting has been complete.

- 1 Press **FUNC1 (MENU)** → **ENTER** (twice) → **ENTER** in LOCAL.  
• MACHINE SETUP MENU will be displayed.
- 2 Press **▲▼** to select "MEDIA REMAIN", and press the **ENTER** key.
- 3 Press **▲▼** to select ON/OFF.
- 4 Press the **ENTER** key.
- 5 Press the **END/POWER** key several times to end the setting.



- When set "ON" the media remaining display, you can print the list of current media remaining amount and the date. (P.2-9)

## Setting the PG Drop Adjust

Adjust the outward and return ink drop positions during bidirectional printing.

PG Drop Adjust adjusts the ink drop positions at two points where the head height is not the same, so that high quality printing can be realized by automatically adjusting the ink drop positions even if the head height changes.

- 1 Press **FUNC1 (MENU)** → **ENTER** (twice) → **ENTER** in LOCAL.  
• MACHINE SETUP MENU will be displayed.
- 2 Press **FUNC3 (>>)**.
- 3 Press **▲▼** to select "PG DROP ADJUST", and press the **ENTER** key.

- 4 Loosen the carriage height adjustment screw and press the **ENTER** key.  
• Loosen the screen by referring to P.2-4 "Adjusting the Head Height".
- 5 With the head height set as 3 mm, tighten the height adjustment screw.
- 6 Press the **ENTER** key twice.  
• Ink drop position adjustment patterns 1 to 5 will be printed.
- 7 Correct the dot positions in patterns 1 to 5 by referring to P.3-6 "If the Positions of Dots Shift...".
- 8 By referring to steps 4 to 7, change the head height to 4 mm and then correct the dot positions in patterns 1 to 5.
- 9 Press the **END/POWER** key several times to end the setting.

## Setting the Media Detection

Set the following two items in media detection settings.

<b>Setting of Media Detection</b>	When setting the media, set whether to detect the media width automatically (AUTO) or decide the print (or cut) range manually (MANUAL).
<b>Setting of Media Thickness</b>	Set whether to enter the thickness of the media during media detection.



- When using the media that cannot be detected by the sensor, set the media detection setting to "MANUAL".

- 1 Press **FUNC1 (MENU)** → **ENTER** (twice) → **ENTER** in LOCAL.  
• MACHINE SETUP MENU will be displayed.
- 2 Press **FUNC3 (>>)**.
- 3 Press **▲▼** to select "MEDIA DETECT", and press the **ENTER** key.
- 4 Press the **ENTER** key.  
• "DETECTION TYPE" will be selected.
- 5 Press **▲▼** to select "AUTO/MANUAL", and press the **ENTER** key.
- 6 Press **▲▼** to select "INPUT THICKNESS", and press **ENTER**.
- 7 Press **▲▼** to select ON/OFF, and press the **ENTER** key.

**8** Press the **END/POWER** key several times to end the setting.

**Important!** • To improve image quality for printing, we recommend selecting “ON” in step 7.

### Setting the Drying Feed

After printing, set the media feed length for drying uniformly to the end of the media.



• According to the position of your optional heater unit 1800 or external heater, please configure that the rear end of printing can pass through the heater.

**1** Press **FUNC1** (MENU) → **▼** (twice) → **ENTER** in LOCAL.  
• MACHINE SETUP MENU will be displayed.

**2** Press **FUNC3** (>>).

**3** Press **▲▼** to select “DRYING FEED”, and press the **ENTER** key.

**4** Press the **ENTER** key.  
• “DRYING FEED” will be selected.

**5** Press **▲▼** to input the feed length of media, and press the **ENTER** key.

**6** Press **▲▼** to select “BACKWARD FEED”, and press the **ENTER** key.

**7** Press **▲▼** to select “ON/OFF”, and press the **ENTER** key.

**8** Press the **END/POWER** key several times to end the setting.

### Setting a LANGUAGE

You can change the displayed language.

**1** Press **FUNC1** (MENU) → **▼** (twice) → **ENTER** in LOCAL.  
• MACHINE SETUP MENU will be displayed.

**2** Press **FUNC3** (>>).

**3** Press **▲▼** to select “LANGUAGE”, and press the **ENTER** key .

**4** Press **▲▼** to select language, and press the **ENTER** key .

**5** Press the **END/POWER** key several times to end the setting.

### Setting Time

You can set time of your country (time difference).

**1** Press **FUNC1** (MENU) → **▼** (twice) → **ENTER** in LOCAL.

• MACHINE SETUP MENU will be displayed.

**2** Press **FUNC3** (>>).

**3** Press **▲▼** to select “TIME”, and press the **ENTER** key.

**4** Press **▲▼◀▶** to enter time, and press the **ENTER** key.

• Year/Month/Day/Time selecting:  
by the [**◀**][**▶**]  
• Year/Month/Day/Time inputting:  
by the [**▲**][**▼**]

**5** Press the **END/POWER** key several times to end the setting.



• -20 hours to +4 hours can be set.

### Setting Unit (Temperature/ Length)

Units used by this machine are set.

**1** Press **FUNC1** (MENU) → **▼** (twice) → **ENTER** in LOCAL.

• MACHINE SETUP MENU will be displayed.

**2** Press **FUNC3** (>>).

**3** Press **▲▼** to select “UNIT/TEMP.” or “UNIT/LENGTH”, and press the **ENTER** key.

**4** Press **▲▼** to select a set value, and press the **ENTER** key.

• Set value of tempture : °C / °F  
• Set value of length : mm / inch

**5** Press the **END/POWER** key several times to end the setting.

## Setting a KEY BUZZER

You can turn off the buzzer sound when pressing the key.

- 1 Press **FUNC1** (MENU) → **▼** (twice) → **ENTER** in LOCAL.  
• MACHINE SETUP MENU will be displayed.
- 2 Press **FUNC3** (>>) twice.
- 3 Press **▲▼** to select “KEY BUZZER”, and press the **ENTER** key.
- 4 Press **▲▼** to select a set value, and press the **ENTER** key.  
• Set value : ON/ OFF
- 5 Press the **END/POWER** key several times to end the setting.



- When the key buzzer is set to "OFF", the buzzer sound for errors, warnings, operation completion, etc. cannot be shut off.

## Setting the VIEW FEED

Set whether media feeding is performed for checking the result of the test printing etc. or not.

- 1 Press **FUNC1** (MENU) → **▼** (twice) → **ENTER** in LOCAL.  
• MACHINE SETUP MENU will be displayed.
- 2 Press **FUNC3** (>>) twice.
- 3 Press **▲▼** to select “VIEW FEED”, and press the **ENTER** key.
- 4 Press **▲▼** to select a set value, and press the **ENTER** key.  
• Set value : ON/ OFF
- 5 Press the **END/POWER** key several times to end the setting.

## Setting the amount of blank space between printed lines

Sets the amount of blank space between printed lines.

- 1 Press **FUNC1** (MENU) in Local.
- 2 Press **▲▼** to select “Machine Setup”, and press the **ENTER** key.

- 3 Press **FUNC3** (>>) twice.

- 4 Press **▲▼** to select “Space Btwn PP.”, and press the **ENTER** key.

- 5 Press **▲▼** to set the amount of blank space, and press the **ENTER** key.  
• Set value : None / 10 to 500 mm

- 6 Press the **END/POWER** key several times to end the setting.

**Important!**

- Back-feed operation is performed when printing ends if the amount of blank space is set in the decreasing direction.  
Be careful of the following in such cases.
- The media tension of the next printing will change due to back-feed, possibly causing the feed rate of the media of only the leading edge of the printed image to change. In such cases, manually rewind the media.
- This function is disabled if back-feed after drying feed is set to OFF in the machine settings “DRYING FEED” (P.3-18).
- If the printed data already has a blank space, using this function will result in “Blank space of the data + Amount of blank space set by using this function” being output as a blank space.

## Setting the SPACE FEED MODE

Change the feed mode of the margin included in the image data (the space of no data to be printed). If print data with much margin, set to “continuous”, then the print time can be shorten.

- 1 Press the **FUNC1** (MENU) → **▼** (twice) → **ENTER** key in LOCAL.  
• MACHINE SETUP MENU will be displayed.

- 2 Press **FUNC3** (>>) twice.

- 3 Press **▲▼** to select “SPACE FEED MODE”, and press the **ENTER** key.

- 4 Press **▲▼** to select a set value, and press the **ENTER** key.

**INTERMITTENT** : Perform intermittent feed operation of the path division unit

**CONTINUOUS** : Feed the no data part at a time

- 5 Press the **END/POWER** key several times to end the setting.

## Set the network

You can also perform network setting with "Network Configurator", the tool to perform network setting of Mimaki's product. To download the Network Configurator, check "Driver / Utility" on the download page at Mimaki Engineering (<http://eng.mimaki.co.jp/download/>).

- 1** Press **FUNC1** (MENU)  $\rightarrow$  **▼** (twice)  $\rightarrow$  **ENTER** in LOCAL.
  - MACHINE SETUP MENU will be displayed.
- 2** Press **FUNC3** (>>) twice.
- 3** Press **▲** **▼** to select "NETWORK", and press the **ENTER** key.
- 4** Press the **ENTER** key.
  - "CHECK IP ADDRESS" will be selected.
  - The IP address currently used by this machine is displayed.
  - When you have finished the check, press the [ENTER] key.



- After connecting with the network, it takes time until the IP address is determined. If the IP address has not been determined, "0.0.0.0" is displayed.

- 5** Press **▼**, and press the **ENTER** key.
  - "CHECK MAC ADDRESS" will be selected.
  - The MAC address currently used by this machine is displayed.
  - When you have finished the check, press the [ENTER] key.
- 6** Press **▼**, and press the **ENTER** key.
  - "DHCP" will be selected.
- 7** Press **▲** **▼** to select a set value, and press the **ENTER** key.
  - Set value : ON/ OFF
  - When it is ON, the IP address given by the DHCP server is used.
- 8** Press **▼**, and press the **ENTER** key.
  - "AutoIP" will be selected.
- 9** Press **▲** **▼** to select a set value, and press the **ENTER** key.
  - Set value : ON/ OFF
  - When it is ON, the IP address is determined by the AutoIP protocol. However, DHCP is ON, DHCP has priority.

- 10** Press **▼**, and press **ENTER**.
  - "IP ADDRESS" will be selected.

- 11** Press **▲** **▼** to select a set value, and press the **ENTER** key.
  - Set value : ON/ OFF
  - Both of DHCP and AutoIP is OFF, you can set IP Address. For other than above, proceed to the Step 14.

- 12** Press **FUNC3**.
  - The setting items DEFAULT GATEWAY, DNS ADDRESS and SUBNET MASK will be displayed.
  - Both of DHCP and AutoIP is OFF, you can set DEFAULT GATEWAY/ DNS ADDRESS/ SUBNET MASK. For other than above, proceed to the Step 14.

- 13** Press **▼** several times to select setting item, and press the **ENTER** key.

- 14** Press **▲** **▼** to select a set value, and press the **ENTER** key.

- 15** Press the **END/POWER** key several times to end the setting.



- To reflect network setting, once turn off the power supply and turn it on again.

## Setting event mail function

Set the function to send e-mails to the set e-mail address when events such as cutting start/ end and stop due to an error.

You can also perform network setting with "Network Configurator", the tool to perform network setting of Mimaki's product. To download the Network Configurator, check "Driver / Utility" on the download page at Mimaki Engineering (<http://eng.mimaki.co.jp/download/>).

- Disclaimer
- The customer is responsible for the communication fee for Internet communication such as e-mail notification.
- The notification by the event mail function may not be delivered due to Internet environment, failure of the device/ the power supply, etc. Mimaki has absolutely no responsibility for any damages or loss resulting from non-delivery or delays.

- Important!**
- You can use event mail function by connecting LAN to this machine. Please prepare for LAN cable connection beforehand.
  - Not compatible with SSL communication.

## Enable the event mail function

- 1** Press **FUNC1** (MENU)  $\rightarrow$  **▼** (twice)  $\rightarrow$  **ENTER** in LOCAL.
  - MACHINE SETUP MENU will be displayed.
- 2** Press **FUNC1** (<<).
- 3** Press **▲** **▼** to select "EVENT MAIL", and press the **ENTER** key.
- 4** Press the **ENTER** key.
  - "MAIL DELIVERY" will be selected.

**5** Press **▲▼** to select “ON”, and press the **ENTER** key.

**6** Press the **END/POWER** key several times to end the setting.

### Set the event to send an event mail

**1** Press **FUNC1** (MENU) **▶▼** (twice) **▶ENTER** in LOCAL.

• MACHINE SETUP MENU will be displayed.

**2** Press **FUNC1** (<<).

**3** Press **▲▼** to select “EVENT MAIL”, and press the **ENTER** key.

**4** Press **▼**, and press the **ENTER** key.  
• “SELECT EVENT” will be selected.

**5** Press **▲▼** to select the event, and press **FUNC2** (✓).

• After selecting the event, press [FUNC2] key and put a check in the check box.

An email will be sent when the event whose box has been checked occurs.

• To select multiple events, use **▲▼** to put the cursor over the events you want, and put a check in their boxes by pressing [FUNC2].

Event name	Outline
PRINT START	Sets sending/not sending of an email when printing starts.
PRINT END	Sets sending/not sending of an email when printing ends.
ERROR	Sets sending/not sending of an email when printing is stopped due to occurrence of an error.
WARNING	Sets sending/not sending of an email when a warning occurs during printing.
etc.	Sets sending/not sending of an email when an event other than the above occurs.

**6** Press the **END/POWER** key several times to end the setting.

### Set the e-mail address

**1** Press **FUNC1** (MENU) **▶▼** (twice) **▶ENTER** in LOCAL.

• MACHINE SETUP MENU will be displayed.

**2** Press **FUNC1** (<<).

**3** Press **▲▼** to select “EVENT MAIL”, and press the **ENTER** key.

**4** Press **▼** twice, and press the **ENTER** key.

• “MAIL ADDRESS” will be selected.

**5** Press **▲▼◀▶** to set mail address, and press the **ENTER** key.

• Set the e-mail address to which you send the event mail.

• Set it with alphanumeric characters and symbols within 96 characters.

**6** Press the **END/POWER** key several times to end the setting.

### Set the subject

**1** Press **FUNC1** (MENU) **▶▼** (twice) **▶ENTER** in LOCAL.

• MACHINE SETUP MENU will be displayed.

**2** Press **FUNC1** (<<).

**3** Press **▲▼** to select “EVENT MAIL”, and press the **ENTER** key.

**4** Press **▼** 3 times, and press the **ENTER** key.

• “MESSAGE SUBJECT” will be selected.

**5** Press **▲▼◀▶** to set subject, and press the **ENTER** key.

• Set the characters to write in the subject of the event mail.

• Set it with alphanumeric characters and symbols within 8 characters.

**6** Press the **END/POWER** key several times to end the setting.

## Set the server

- 1 Press **FUNC1** (MENU)  $\rightarrow$  **▼** (twice)  $\rightarrow$  **ENTER** in LOCAL.
  - MACHINE SETUP MENU will be displayed.
- 2 Press **FUNC1** (<<).
- 3 Press **▲▼** to select "EVENT MAIL", and press the **ENTER** key.
- 4 Press **▼** 4 times, and press the **ENTER** key.
  - "SERVER SETUP" will be selected.
- 5 Press the **ENTER** key.
  - "SMTP ADDRESS" will be selected.
- 6 Press **▲▼◀▶** to set SMTP Address, and press the **ENTER** key.
  - Press jog key [**▲▼**][**◀▶**] to set SMTP address.
  - Input the SMTP address name.
- 7 Press **▼**, and press the **ENTER** key.
  - "SMTP PORT No." will be selected.
- 8 Press **▲▼** to set SMTP Port No., and press the **ENTER** key.
  - Set the SMTP port number.
- 9 Press **▼**, and press the **ENTER** key.
  - "SENDER ADDRESS" will be selected.
- 10 Press **▲▼◀▶** to set SENDER ADDRESS, and press the **ENTER** key.
  - Press [**▲▼**][**◀▶**] and set the e-mail address to be used as the sender mail address.
  - Set it with alphanumeric characters and symbols within 64 characters.

  - Depending on your server, if you do not set the e-mail address not supporting the account, sending/ receiving e-mails may be unavailable.
- 11 Press **▼**, and press the **ENTER** key.
  - "AUTHENTICATION" will be selected.
- 12 Press **▲▼** to set authentication method, and press the **ENTER** key.
  - Set the authentication method of the SMTP server.
  - When you select [OFF], proceed to the Step 20.
- 13 Press **▼**, and press the **ENTER** key.
  - "USER NAME" will be selected.
- 14 Press **▲▼◀▶** to set User Name, and press the **ENTER** key.
  - Press [**▲▼**][**◀▶**] to set the user name to use for the authentication.
  - Set it with alphanumeric characters and symbols within 30 characters.
- 15 Press **▼**, and press the **ENTER** key.
  - "PASSWORD" will be selected.
- 16 Press **▲▼◀▶** to set Password, and press the **ENTER** key.
  - Press [**▲▼**][**◀▶**] to set the password to use for the authentication.
  - Set it with alphanumeric characters and symbols within 15 characters.

  - On the password setting screen, you can only check the value that you are currently inputting.

  - When you select [POP before SMTP] in the Step 11, set the items in the Step 16 to 19.
- 17 Press **▼**, and press the **ENTER** key.
  - "POP3 ADDRESS" will be selected.
- 18 Press **▲▼◀▶** to set POP3 Address, and press the **ENTER** key.
  - Press [**▲▼**][**◀▶**] to set POP server.
  - Input the POP server name.
- 19 Press **▼**, and press the **ENTER** key.
  - "APOPOP" will be selected.
- 20 Press **▲▼** to set ON/ OFF, and press the **ENTER** key.
- 21 Press the **END/POWER** key several times to end the setting.

## Send a test e-mail

- 1** Press **FUNC1** (MENU) **▶** **▼** (twice) **▶** **ENTER** in LOCAL.
  - MACHINE SETUP MENU will be displayed.
- 2** Press **FUNC1** (<<).
- 3** Press **▲** **▼** to select “EVENT MAIL”, and press the **ENTER** key.
- 4** Press **FUNC3** (>>) **▶** **ENTER** .
  - “TRANSMIT TEST” will be selected.

- 5** Press the **ENTER** key.
  - The sent result is displayed.
  - If sending test e-mail has failed, an error code is displayed.  
Refer to the next page to solve the problem.

```
Transmit Test
Failed: 12345 :ent
```

- 6** Press the **END/POWER** key several times to end the setting.

### Important!

- The sent result of the test e-mail is the result of e-mail sending process performed by this machine to the e-mail server. It does not indicate that the e-mail was received at the address.
- If the spam e-mail filter etc. has been set in the terminal in which e-mails are received, even if “Sending has been completed” is displayed, the e-mail cannot be received in some cases.
- If sending test e-mail has failed, the error code below is displayed.
- If the error cannot be solved, try again after a while.
- For the server setting etc., contact with the network administrator or the provider.

Error Code	The expected casus	Remedy
10	Network connection error	<ul style="list-style-type: none"> <li>• Check that the machine is connected with the network.</li> <li>• Check that the machine IP address is correct.</li> <li>• Check that the machine is in the environment where DNS is available.</li> </ul>
20	No valid e-mail address.	<ul style="list-style-type: none"> <li>• Enter the correct e-mail address.</li> </ul>
11003 11004	The POP server cannot be found. Or cannot access DNS server.	<ul style="list-style-type: none"> <li>• Check the POP server address.</li> <li>• Check that the machine is in the environment where DNS is available.</li> </ul>
11021	Cannot connect with the POP server.	<ul style="list-style-type: none"> <li>• Check the POP server setting.</li> <li>• Check the firewall setting.</li> </ul>
12010	An error returns from the POP server.	<ul style="list-style-type: none"> <li>• Check the POP server setting.</li> </ul>
13000	The POP authentication has failed.	<ul style="list-style-type: none"> <li>• Check the user name and the password.</li> <li>• Check the APOP setting.</li> <li>• Confirm the authentication method.</li> </ul>
10013 10014	The SMTP server cannot be found. Or cannot access DNS server.	<ul style="list-style-type: none"> <li>• Check the SMTP server address.</li> <li>• Check that the machine is in the environment where DNS is available.</li> </ul>
10021	Cannot connect with the SMTP server.	<ul style="list-style-type: none"> <li>• Check the SMTP server setting.</li> <li>• Check the SMTP port number.</li> <li>• Check the firewall setting.</li> </ul>
10*** 11*** 20*** 21***	An error returns from the SMTP server. Or, there was no response.	<ul style="list-style-type: none"> <li>• Check the SMTP server setting.</li> <li>• Cannot communicate with a server that requires mandatory SSL communication.</li> <li>• Check protocol filter settings.</li> </ul>
12***	It is invalid sender address.	<ul style="list-style-type: none"> <li>• Check that the e-mail address supporting the account entered in the user name/ the password is set in SENDER ADDRESS.</li> </ul>
13***	The e-mail address cannot be found. Or, it is invalid sender address.	<ul style="list-style-type: none"> <li>• Check the e-mail address.</li> <li>• Even if there is a mistake in the e-mail address, this error cannot be detected in some cases.</li> <li>• Check that the e-mail address supporting the account entered in the user name/ the password is set in SENDER ADDRESS.</li> </ul>
22000 22008	SMTP authentication error	<ul style="list-style-type: none"> <li>• Confirm the authentication method.</li> </ul>
23*** 24*** 25***	The SMTP authentication has failed.	<ul style="list-style-type: none"> <li>• Check the user name and the password.</li> </ul>

“\*\*\*” is the error code returned from the e-mail server.

## Initializing the Settings

You can return the setting of “SETUP”, “MAINTENANCE” and “MACHINE SETUP” to the status before shipment.

- 1** Press **FUNC1 (MENU)** → **▼** (twice) → **ENTER** in **LOCAL**.
  - MACHINE SETUP MENU will be displayed.
- 2** Press **FUNC1 (<<)**.
- 3** Press **▲** **▼** to select “RESET”, and press the **ENTER** key.
- 4** Press the **ENTER** key.
  - The already configured settings are initialized.
- 5** Press the **END/POWER** key several times to end the setting.



# About NOZZLE CHECK MENU

Set operations concerning the nozzle missing detection function.

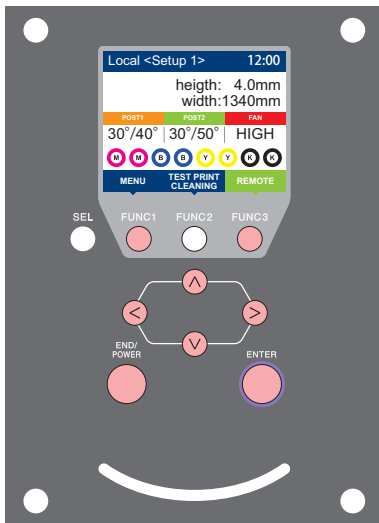

- FUNC1** : Press this to select INFORMATION MENU, or to switch to the previous screen.
- FUNC3** : Press this to switch to the next screen.
- ▲ ▼** : Use these to select a setting item.
- ENTER** : Press this to confirm a setting, etc..

## ◆ NOZZLE CHECK MENUs at-a-glance

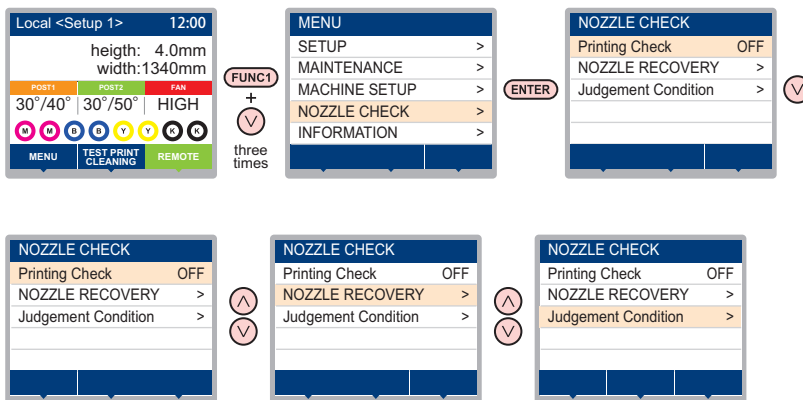

## INFORMATION MENU table

Function name		Set value	Default	Meaning	
(ON)	Printing Check (P.3-26)	ON/OFF	OFF	Set this when you want to conduct nozzle check at the beginning of online printing.	
		Check Interval	LENGTH	0.1 to 50.0m	30.0 m
	FILE		1 to 100	30 file	Conducts nozzle check at each set number of files.*1
	Action	CLEANING	OFF/ SOFT/ NORMAL/ HARD	SOFT	Sets the type of cleaning performed during recovery work.
RETRY COUNT		0 to 3	0	Repeats the retry operation for the set number of times.	
NOZZLE RECOVERY (P.3-27)		ON/OFF	OFF	Set this when you want to conduct automatic nozzle recovery.	
Judgement Condition (P.3-27)		1 to 200	1	Sets how many missing nozzles are detected for "Nozzle Missing" judgment to be made according to each color. (Maximum 16 per 1 nozzle line)*2	

\*1. When the set length is reached during printing, nozzle check is conducted at the start of the next printing.

\*2. Depending on the print conditions, nozzle recovery is not applied in some cases.

## Printing Check Flow

Nozzle check is conducted according to the following flow at the start of printing.



- Turn the “Printing Check” setting ON to be enabled.
- Only perform RETRY COUNT and Printing Check settings when the settings are enabled.

### 1 nozzle check → Judgment

Detects missing nozzles.

### 2 Recovery operation → nozzle check → Judgment

If more missing nozzles than “Judgement Condition ” are detected after the nozzle check, cleaning is performed and nozzle check is conducted again.

### 3 Retry → Judgment

If more missing nozzles than “Judgement Condition ” are detected after the recovery operation, the recovery operation is conducted again.

### 4 Printing Check → Judgment

Nozzle recovery is automatically conducted following nozzle check and recovery operation.

- Turn the “Printing Check” setting ON to be enabled.

### 5 Nozzle Missing judgment

If more missing nozzles than A are eventually detected, continued printing will be deemed impossible and printing will stop.

## Printing Operations at “Nozzle Missing” Judgment and Error Occurrence

- When judged to be “Nozzle Missing” → Printing is stopped.
- When error occurs during nozzle check → Printing is stopped and “Printing Check” is automatically turned OFF. After recovering from the error, set “Printing Check” once again.

## Setting the Printing Check

Select ON when you want to conduct nozzle check at the start of online printing.

- 1 Press **FUNC1** (MENU)  $\rightarrow$   $\downarrow$  (3 times)  $\rightarrow$  **ENTER** in LOCAL.
  - NOZZLE CHECK MENU will be displayed.
- 2 Press the **ENTER** key.
  - "Printing Check" will be selected.
- 3 Press  $\uparrow$   $\downarrow$  to select ON, and press the **ENTER** key.
  - The "Check Interval" setting screen will be displayed.
  - "Select OFF to not set nozzle check. Proceed to Step 11.
- 4 Press the **ENTER** key.
- 5 Press  $\uparrow$   $\downarrow$  to select setting item, and press the **ENTER** key.
  - select the nozzle check interval from "LENGTH" or "FILE".
  - LENGTH** : nozzle check is conducted when the printed length reaches the set length.
  - FILE** : nozzle check is conducted when the number of printed files reaches the set number.
- 6 Press  $\uparrow$   $\downarrow$  to select setting value, and press the **ENTER** key.
  - The set value will differ according to the setting selected in Step 5.
  - LENGTH** : 0.1 to 50.0 m
  - FILE** : 1 to 100 files
- 7 Press the **ENTER** key twice.
  - The "Action" setting screen will be displayed.
- 8 Press the **ENTER** key.
  - "CLEANING TYPE" will be selected.
- 9 Press  $\uparrow$   $\downarrow$  to select cleaning type, and press the **ENTER** key.
 

Setting value : OFF/SOFT/ NORMAL/ HARD
- 10 Press  $\uparrow$   $\downarrow$  to select retry count, and press **ENTER** .
 

Setting value : 0 to 3
- 11 Press the **END/POWER** key several times to end the setting.

## Setting the NOZZLE RECOVERY

set this if you want to conduct automatic nozzle recovery when nozzle missing is detected.

- 1 Press **FUNC1** (MENU)  $\rightarrow$   $\downarrow$  (3 times)  $\rightarrow$  **ENTER** in LOCAL.
  - NOZZLE CHECK MENU will be displayed.
- 2 Press  $\downarrow$ , and press the **ENTER** key.
  - "NOZZLE RECOVERY" will be selected.
- 3 Press  $\uparrow$   $\downarrow$  to select ON/OFF, and press **ENTER** .
- 4 Press the **END/POWER** key several times to end the setting.

## Setting the Judgment Condition

Set the conditions for judging nozzle missing.

- 1 Press **FUNC1** (MENU)  $\rightarrow$   $\downarrow$  (3 times)  $\rightarrow$  **ENTER** in LOCAL.
  - NOZZLE CHECK MENU will be displayed.
- 2 Press  $\downarrow$  twice, and press the **ENTER** key.
  - "Judgement Condition" will be selected.
- 3 Press  $\uparrow$   $\downarrow$  to select color, and press the **ENTER** key.
  - The type of color changes depending on the ink set.
- 4 Press  $\uparrow$   $\downarrow$  to set the number of nozzles for judgment, and press the **ENTER** key.
- 5 Press the **END/POWER** key several times to end the setting.

# About INFORMATION MENU

The information of this machine can be confirmed.  
The following items can be confirmed as machine information.

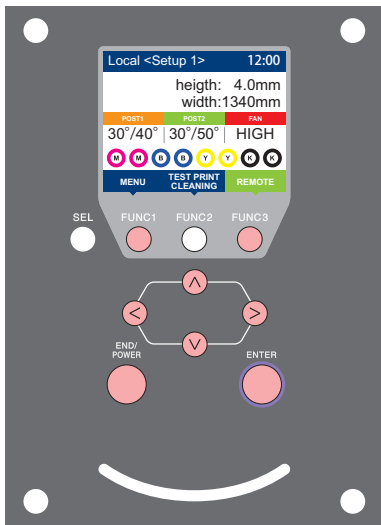

- FUNC1** : Press this to select INFORMATION MENU, or to switch to the previous screen.
- FUNC3** : Press this to switch to the next screen.
- ▲ ▼** : Use these to select a setting item.
- ENTER** : Press this to confirm a setting, etc..

## ◆ INFORMATION MENUs at-a-glance

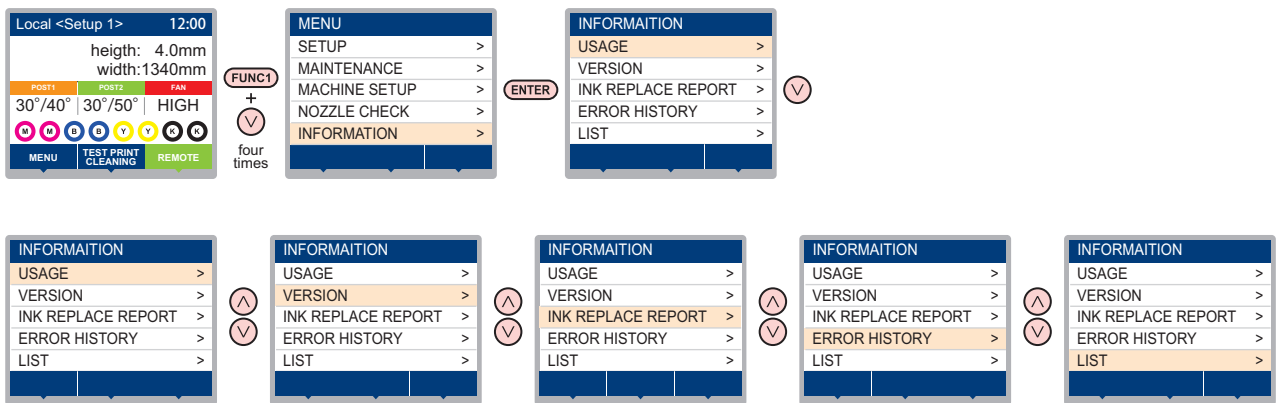

## INFORMATION MENU table

Item	Description	
USAGE	WIPING	This displays how many wipings have been done.
	WASTE TANK	This displays how much waste ink has built up in the waste ink tank, as a rough percentage of the tank capacity.
	PRINT LENGTH	This displays the total length of the printing done to date.
	PRINT AREA	This displays the total area of the printing done to date.
	USE TIME	This displays the total time for which the printer has been used to date.
	Spout Rubber	This displays the total time for which Spout Rubber has been used.
VERSION	This displays the version information of this machine.	
Ink REPL. Report	This prints ink history of this machine.	
ERROR HISTORY	This displays the history of errors and warnings to date. When you press [▲][▼], the date of occurrence (year/month/day/hour/minute) and the error/warning information are displayed alternately in the order of occurrence.	
LIST	This allows you to print the settings of this machine.	

## Displaying the Information

- 1 Press **FUNC1 (MENU)** → **▼** (4 times) → **ENTER** in LOCAL.
  - INFORMATION MENU will be displayed.
- 2 Press **▲▼** to select a information.
  - Refer to the “INFORMATION MENU”, and select the information to be displayed.
- 3 Press the **ENTER** key.
  - If you selected [LIST] in step 2, the machine’s settings will be printed.
- 4 Press the **END/POWER** key several times to end the setting.



- When you reset the used count of the wiper, press [FUNC2] key while [RESET?] is displayed. When you press the [ENTER] key, the number of wipings is reset.
- By pressing the function key during display of “WIPING information,” “WASTE TANK information” and “Spout Rubber” in USAGE, the used counts can be reset.
 

<b>When resetting WIPING information</b>	: Press [FUNC2]
<b>When resetting WASTE TANK information</b>	: Press [FUNC1]
<b>When resetting Spout Rubber</b>	: Press [FUNC3]



# Chapter 4

## Maintenance



### This chapter

describes the items required to use this machine more comfortably, which are the methods for the daily care, the maintenance of the ink cartridges etc.





Maintenance .....	4-3	Check the condition for which nozzle recovery cannot be performed .....	4-15
Precautions for Maintenance .....	4-3	Enabling or disabling nozzle recovery during a test print .....	4-15
About Cleaning Solution .....	4-3	Automatic Maintenance Function .....	4-16
Cleaning the Exterior Surfaces .....	4-3	Setting the Refreshing Intervals .....	4-16
Cleaning the Platen .....	4-3	Setting the Tube Wash Intervals .....	4-16
Cleaning the Media Sensor .....	4-4	Setting the Cleaning Intervals and Type .....	4-16
Cleaning the Media Press .....	4-4	Suspend the nozzle cleaning .....	4-17
About MAINTENANCE MENU .....	4-5	Fill up Ink .....	4-17
MAINTENANCE MENUs at-a-glance .....	4-6	Replacing consumables .....	4-17
Maintaining the Capping Station .....	4-7	Replacing the wiper .....	4-17
Cleaning the Wiper and Cap .....	4-7	If a Waste Ink Tank Confirmation Message Appears .....	4-18
Washing the Head Nozzle .....	4-8	Replace the waste ink tank with another .....	4-19
Washing the Ink Discharge Passage .....	4-10	Replacing the Cutter Blade .....	4-20
When the Machine Is Not Used for a Long Time .....	4-11	Replacing the Spout Rubber .....	4-21
Cleaning the Ink Head and the Area around It .....	4-13	Male Connector Absorbent for MBIS .....	4-22
Nozzle Recovery Function .....	4-14		
Reset the set value .....	4-15		

# Maintenance

Maintain the machine regularly or as necessary so that its accuracy will be maintained and it can continue to be used for a long time.

## Precautions for Maintenance

Pay attention to the following items when maintaining this machine.

	<ul style="list-style-type: none"> <li>When using cleaning solution for maintenance, be sure to wear the supplied protective glasses.</li> </ul>
	<ul style="list-style-type: none"> <li>Never disassemble the machine. Disassembling it can result in electric shock hazards or damage to the machine.</li> <li>Before maintenance, be sure to turn off the power switch and unplug the power cable; otherwise, an unexpected accident may occur.</li> </ul>
	<ul style="list-style-type: none"> <li>Prevent moisture from entering the machine. Moisture inside the machine can cause electric shock hazards or damage to the machine.</li> </ul>
	<ul style="list-style-type: none"> <li>To ensure stable ink jetting, it is necessary for the machine to eject a small amount of ink (flushing) regularly when a printing (outputting) operation has not been performed for a long time.</li> <li>When the machine is not to be used for a long time, turn off only the power switch on the front side, leave the main power switch at the right side turned ON (in the position of   ), and leave the power cable connected.</li> </ul>
	<ul style="list-style-type: none"> <li>Do not wipe the nozzle face of the heads, wiper, caps, etc. with water or alcohol. Doing so can cause nozzle clogging or machine failure.</li> <li>Do not use benzene, thinner, or any chemical agent containing an abrasive. Such materials can deteriorate or deform the surface of the cover.</li> <li>Do not apply a lubricant, etc. to any parts inside the machine. Doing so can cause printing failure.</li> <li>Be careful that the cleaning solution, ink, etc. not to stick to the cover because this may cause the surface of the cover to deteriorate or deform.</li> </ul>

## About Cleaning Solution

Use the cleaning liquid dedicated for the ink being used.

Type of Ink	Applicable maintenance washings
Sublimation dye ink:Sb410 Sublimation dye ink:Sb411	Cleaning Liquid 03 MAINTENANCE KIT (ML003-2-K1) [Sold separately]

## Cleaning the Exterior Surfaces

When the exterior surfaces of the machine are stained, dampen a soft cloth with water or a neutral detergent diluted with water, squeeze it, and wipe the surfaces with the cloth.

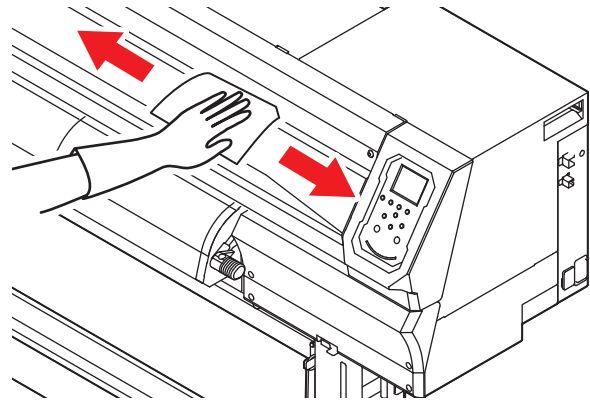

## Cleaning the Platen

The platen easily gets dirty with lint, paper dust, etc. generated when a media is cut. Wipe off conspicuous stains with a soft-hair brush, a dry cloth, a paper towel, etc.

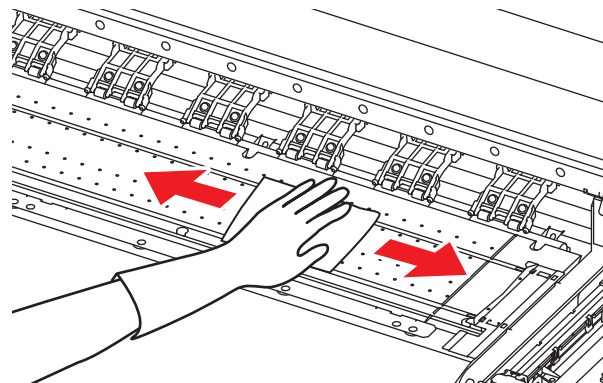

- When the platen is stained with ink, wipe it off with a paper towel containing a small amount of cleaning solution for maintenance.



- Before cleaning the platen, make sure that the platen has cooled adequately.
- Because dust and dirt are easily accumulated in the slots for holding a media and cutting paper (cutter line), be sure to clean these parts carefully.



## Cleaning the Media Sensor

The media sensors are located on the platen in the backside and the bottom surface of the head. When the sensor is covered with dust, etc., it may cause false detection of media.

Using a cotton swab, remove the dust, etc. accumulated on the surface of the sensor.

When cleaning the sensor on the lower surface of the head is cleaned, move the carriage to the left end by the operations of step 1 of P.4-12 "Cleaning the Ink Head and the Area around It", and clean it.

### The backside of the machine

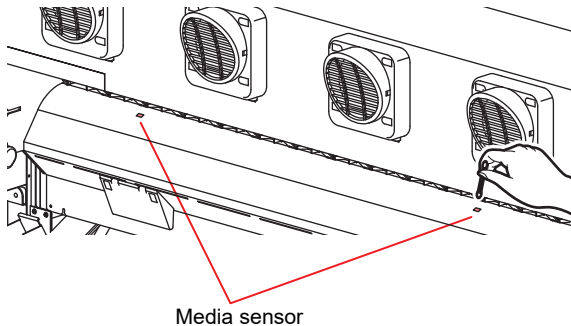

### The lower surface of the head

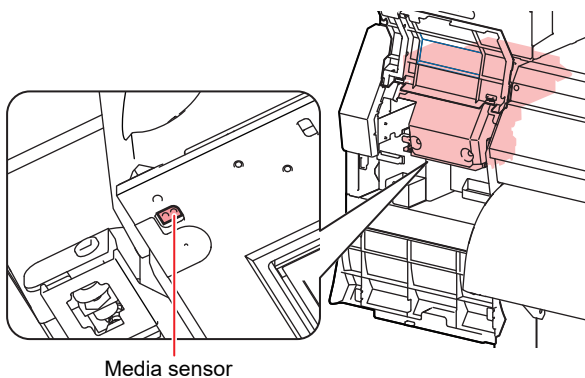

Media sensor



- Don't touch the cutter around the media sensor. Sharp cutter tip may injure you.

## Cleaning the Media Press

When the media press is covered with lint, dust, etc., a media cannot be fed normally during printing or dust sticks to the nozzles, which may result in abnormal printing.

Clean the media press regularly.

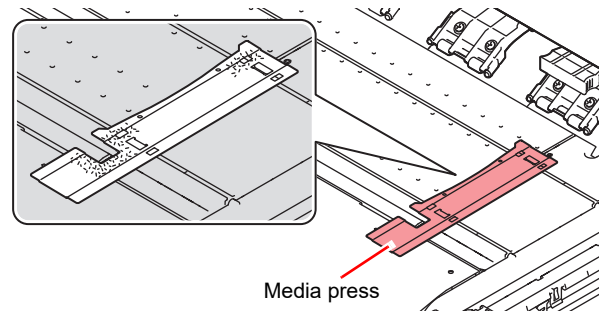

# About MAINTENANCE MENU

This provides various settings for doing maintenance on the machine.  
The following items can be set in Maintenance settings.

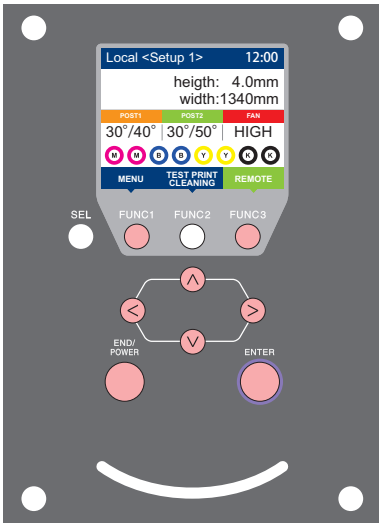

- FUNC1** : Press this to select MAINTENANCE MENU, or to switch to the previous screen.
- FUNC2** : Press this to use the maintenance function.
- FUNC3** : Press this to switch to the next screen.
- ▲ ▼** : Use these to select a setting item.
- ENTER** : Press this to confirm a setting, etc..

## ◆ MAINTENANCE MENUs at-a-glance

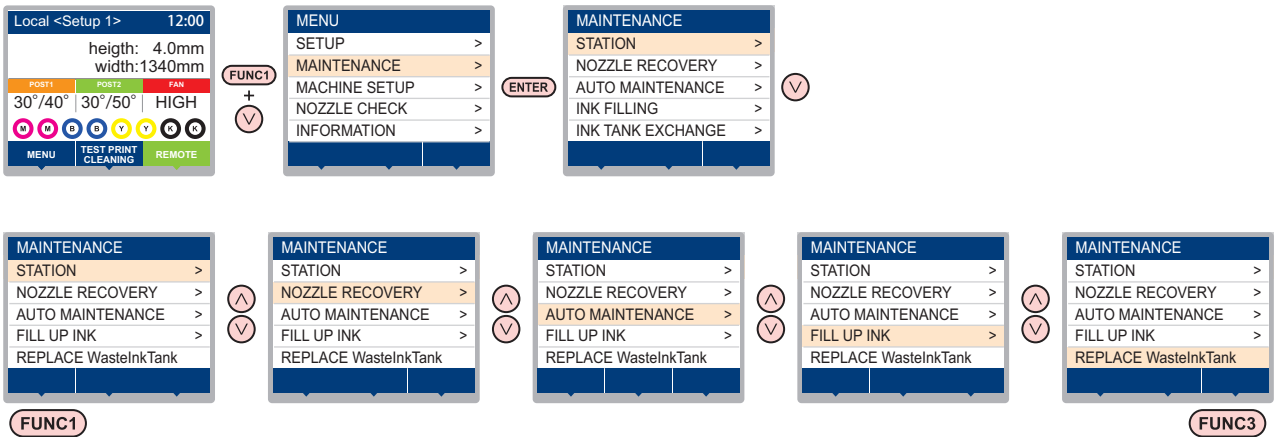

## ◆ Screen transition when **FUNC2** is pressed

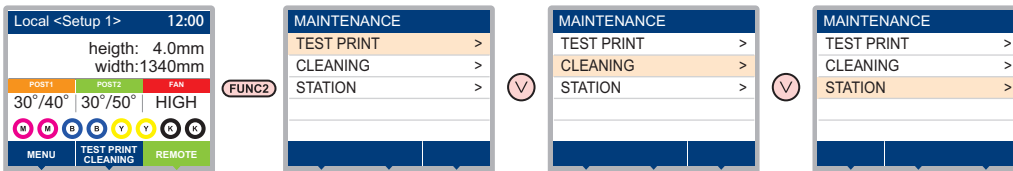

## MAINTENANCE MENUs at-a-glance

Item	Set value	Meaning	
STATION MAINTENANCE	For carrying out maintenance on the carriage and station periphery.		
	CARRIAGE OUT (☞ P.4-6)	_____	Moves the carriage out, for carrying out cleaning of the cap periphery, head, wipers, etc.
	NOZZLE WASH (☞ P.4-7)	1 to 99min	Soaks the nozzle surfaces in maintenance cleaning fluid, for carrying out recovery from nozzle clogging or bent.
	DISWAY WASH (☞ P.4-9)	_____	Executes washing of the suction pump tubes.
	CUSTODY WASH (☞ P.4-10)	1 to 99min	Carried out when the machine is going to be out of use for an extended period. Washes the nozzles and tubes beforehand, to keep the machine in fine condition.
	WIPER EXCHANGE (☞ P.4-16)		Used when replacing the wiper. If the wiper is replaced, the number of times the wiper was used that is managed in this machine is reset.
NOZZLE RECOVERY (☞ P.4-13)	For printing using another nozzle, if nozzle wash and so forth fail to effect recovery from nozzle missing, etc.		
	PRINT		Used to print a pattern and to check and/or register clogged nozzles.
	ENTRY		Registers the faulty nozzle identified by "PRINT".
	RESET		Resets a registered faulty nozzle.
	CHECK		Checks recoverable printable conditions.
	TEST PRINT	ON/OFF	Enables or disables the configuration of the nozzle recovery function during a test print.
AUTO MAINT. (☞ P.4-15)	For having the various maintenance functions executed automatically. Set the execution interval for each maintenance function.		
	REFRESH	The setting is different depending on your ink type.	For setting the activation interval for refresh.
	PUMP TUBE CLEANING		For setting the activation interval for the ink discharge passage cleaning.
	CLEANING	INTERVAL	For setting the activation interval for the head cleaning.
TYPE		NORMAL/ HARD	Select the cleaning type for head cleaning.
FILL UP INK (☞ P.4-16)	Supplies ink to correct nozzle clogging.		
REPLACE WasteInkTank (☞ P.4-18)	Resets or corrects the used count for the waste ink tank.		

# Maintaining the Capping Station

Maintain the ink cap, wiper, etc. located in the capping station. (SATION MAINT.)

- Important!**
- To keep the nozzle status normal, perform wiper cleaning frequently.

The ink cap and wiper function as follows.

- Wiper** : It wipes off ink sticking to the head nozzles.
- Ink cap** : It prevents the head nozzles from clogging due to dryness.

As the machine is used repeatedly, the wiper and ink cap gradually become dirty with ink, dust, etc.

If nozzle missing cannot be corrected even after head cleaning (P.2-17) has been performed, use a Cleaning Liquid 03 MAINTENANCE KIT and clean stick.

## Tools required for Maintenance

- |   |          |                  |
|---|----------|------------------|
| • Cleaning Liquid 03 MAINTENANCE KIT (ML003-Z-K1) |          |                  |
| • Clean stick (SPC-0527)                          | • Gloves | • Safety glasses |



- Be sure to wear the supplied safety glasses and gloves when maintaining the capping station. Otherwise, you may get ink in your eyes.
- Do not move the carriage out of the capping station by hand. When it is desirable to move the carriage, press [FUNC1] key to execute the carriage-out. (P.4-6Steps 1 to 2)

## Cleaning the Wiper and Cap

It is recommended that the wiper and cap be cleaned frequently in order to maintain the high image quality of the machine and keep the machine itself in good working order.

- Important!**
- Replace the wiper with a new one when it is extremely dirty or bent. (P.4-16)
  - When cleaning the wiper, be careful that lint from the clean stick does not get left on the wiper. Remaining lint may cause image quality to deteriorate.

**1** Press **[FUNC1] (MENU) → [▼] → [ENTER]** in **LOCAL**.

- MAINTENANCE MENU will be displayed.

**2** Press the **[ENTER]** key twice.

- The carriage moves onto the platen.

**3** Open the front cover.

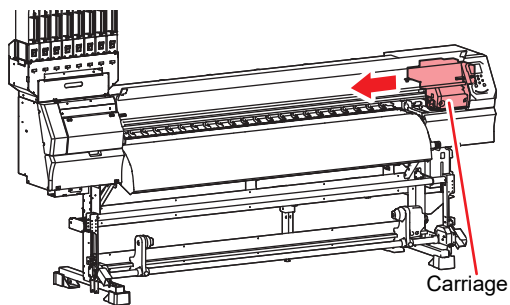

**4** Remove the wiper.

- Pull out the wiper by holding the protrusions at its both ends.

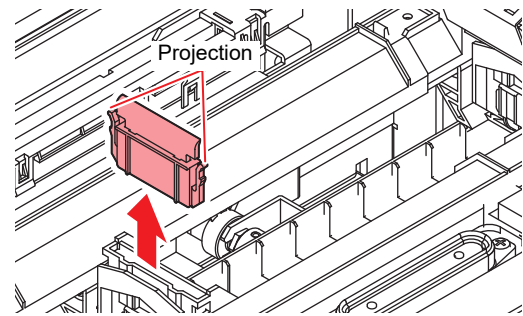

**5** Clean the wiper and bracket.

- Wipe off the ink sticking to the wiper and bracket with a clean stick dipped in cleaning solution for maintenance. Wipe off so that cleaning solution for maintenance will not remain.

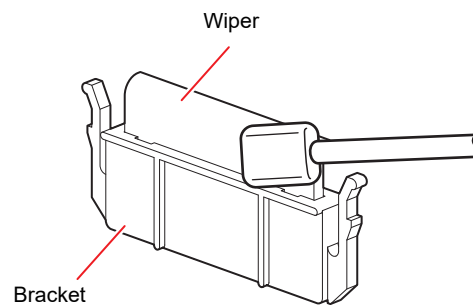

**6** Clean the wiper cleaner.

- Wipe off the ink sticking to the wiper cleaner with a clean stick dipped in cleaning solution for maintenance. Wipe off so that cleaning solution for maintenance will not remain.

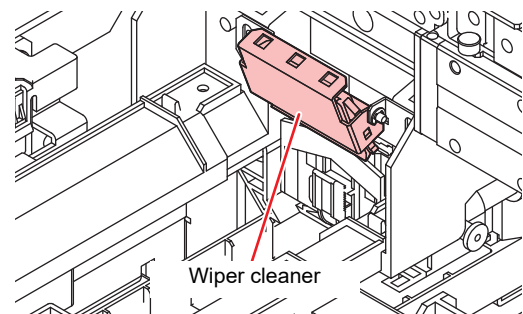

- If there is a large amount of ink in the absorbent case, wipe it away using water-absorbent paper or the like.

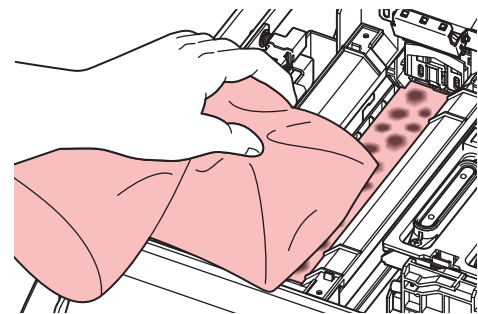



- Do not remove the wiper cleaner from the bracket.
- Only clean the front surface on the wiper cleaner's wiper. (You do not need to clean the rear surface.)
- Do not remove the absorbent material in the absorbent case.
- After the wiper cleaner cleaning, make sure that the cleaner is not facing up.

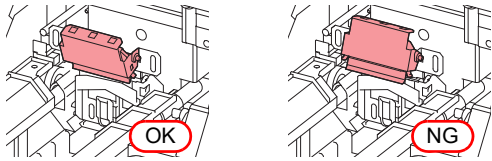

## 7 Set the wiper at the original position.

- Insert the wiper by holding the protrusions at its both ends.

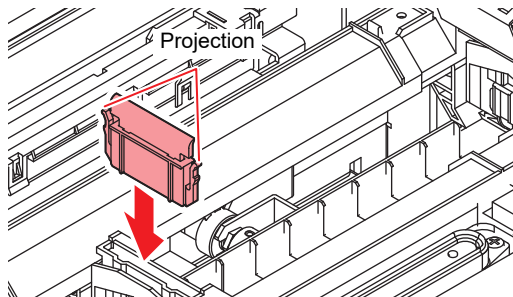

## 8 Clean the cap rubber.

- Wipe off the ink sticking to the cap rubber with a clean stick dipped in maintenance solution for maintenance.
- Wipe off so that maintenance solution for maintenance will not remain.

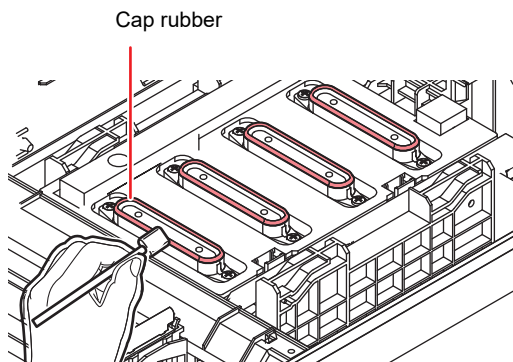

- After cleaning the cap rubber, check to make sure the cap slider is not tilted.
- If it is tilted, move the slider block left and right to fix its tilt.

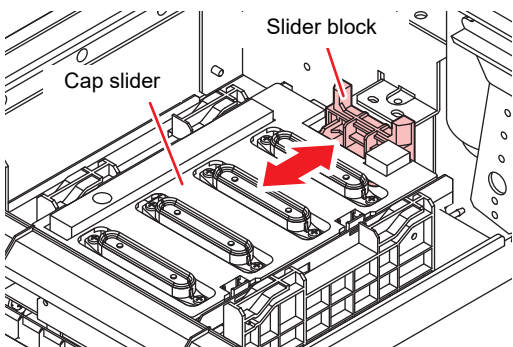

## 9 Press the **ENTER** key after the cleaning.

## 10 Close the front cover then press the **ENTER** key.

- After its initial operation, the machine returns to step1.

## Washing the Head Nozzle

### 1 Press **FUNC1** (MENU) → **ENTER** in LOCAL.

- MAINTENANCE MENU will be displayed.

### 2 Press **ENTER**.

- "STATION" will be selected.

### 3 Press **▲** **▼** to select "NOZZLE WASH", and press the **ENTER** key.

### 4 Press **▲** **▼** to select the washing head, and press the **ENTER** key.

### 5 When "WIPER CLEANING" appears on the display, open the front cover.

### 6 Clean the wiper and the bracket, and press the **ENTER** key.

- (1) Open the right maintenance cover then pull out it by holding projections at both ends of the wiper.
- (2) Clean the wiper and bracket with a clean stick dipped in maintenance washing liquid for maintenance.
  - Wipe off so that maintenance washing liquid for maintenance will not remain.
- (3) Insert it in the original position by holding the projections at both ends of the wiper.

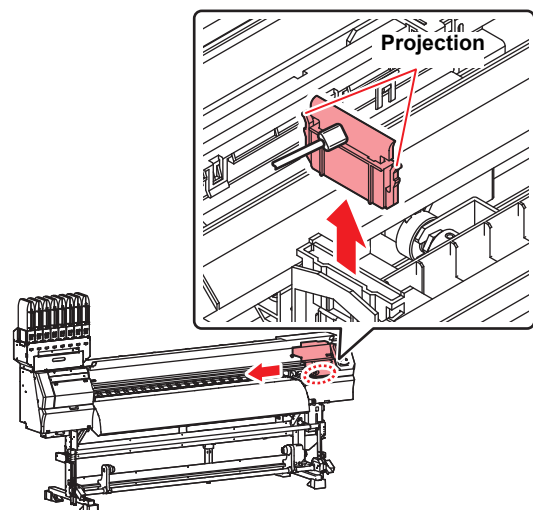

**Important!**

- After cleaning the wiper, check to make sure the cap slider is not tilted. If it is tilted, move the slider block left and right to fix its tilt.

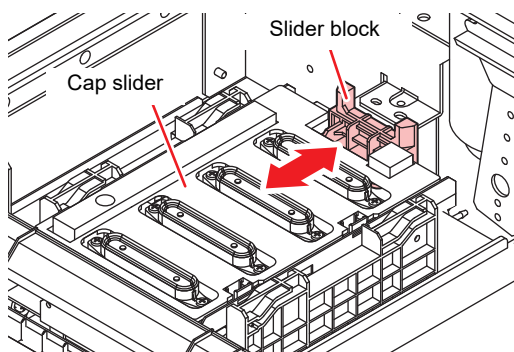

**7**

**When cleaning of the cap rubber is complete, close the front cover and press the **ENTER** key.**

- Wipe off the ink sticking to the cap rubber with a clean stick dipped in maintenance washing liquid for maintenance.
- Wipe off so that maintenance washing liquid for maintenance will not remain.
- At this time, the discharge passage is cleaned automatically.

**8**

**Fill up the cap with cleaning solution for maintenance.**

- If the cleaning solution cartridge is usable, maintenance solution is automatically filled.
- When the cap is filled with cleaning solution, the display will prompt you to check the cleaning solution.

**Important!**

- If the front cover is not closed, the cleaning solution will not be automatically filled. If the front cover is open, be sure to close it.



- If the cleaning cartridge is not valid, the cleaning solution will not be automatically filled to the cap. Open the front cover and use a dropper to fill the maintenance cleaning solution in the cap to just before it overflows. Once the cleaning solution is full, begin from Step 10.

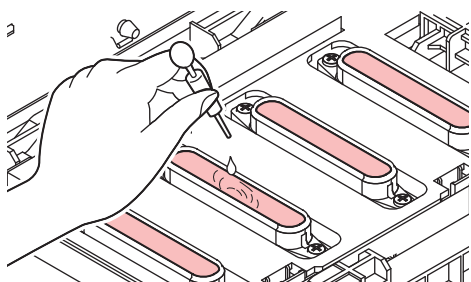

**9**

**If a message is displayed, open the front cover and check the amount of cleaning solution in the cap.**

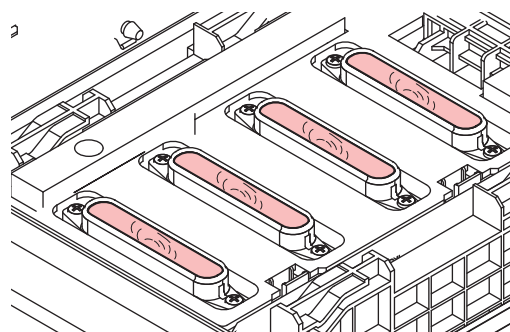

**Important!**

- If the solution does not fill up the cap, use a dropper to fill the maintenance cleaning solution in the cap to just before it overflows.

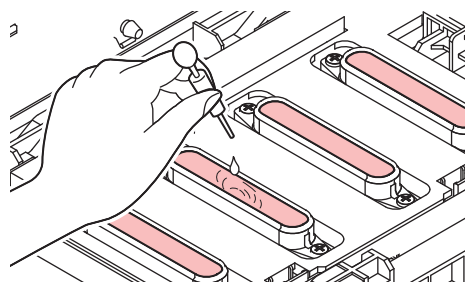

**10**

**Close the front cover, and press the **ENTER** key.**

**11**

**Press **▲** **▼** to set the time for the maintenance washing liquid to be left as it is, and press the **ENTER** key.**

- **Set value** : 1 to 99 minutes (Unit: minute)
- The maintenance washing liquid filled in the cap is absorbed.
- "Please Wait" will be displayed in the display until the time you set has elapsed.

**Important!**

- When nozzle missing is not cleared even after nozzle recovery (P.4-13) or this washing is carried out several times, contact the distributor in your region or our service office.

## Washing the Ink Discharge Passage

Wash the ink discharge passage regularly (about once a week) to prevent the head nozzles from clogging due to ink coagulation inside the passage.

- Important!**
- Before washing the ink discharge passage, make sure that the maintenance washing liquid is set. If the maintenance washing liquid is not set, washing operation will not be conducted and the passage could be clogged.

**1** Press **FUNC1 (MENU)** → **ENTER** in **LOCAL**.  
 • MAINTENANCE MENU will be displayed.

**2** Press the **ENTER** key.  
 • "STATION" will be selected.

**3** Press **▲ ▼** to select "DISWAY WASH", and press the **ENTER** key.

**4** Press **▲ ▼** to select the washing head, and press the **ENTER** key.

**5** Fill up the cap with cleaning solution for maintenance.

- If the cleaning solution cartridge is usable, maintenance solution is automatically filled.

- Important!**
- If the front cover is not closed, the cleaning solution will not be automatically filled. If the front cover is open, be sure to close it.



- If the cleaning cartridge is not valid, the cleaning solution will not be automatically filled to the cap. Open the front cover and use a dropper to fill the maintenance cleaning solution in the cap to just before it overflows. Once the cleaning solution is full, begin from Step 7.

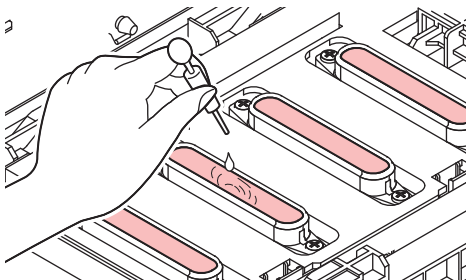

**6** If a **END** message is displayed, open the front cover and check the amount of cleaning solution in the cap.

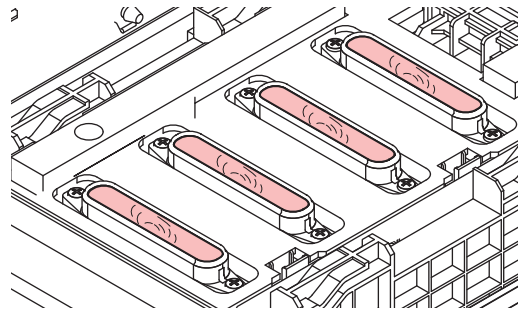

- Important!**
- If the solution does not fill up the cap, use a dropper to fill the maintenance cleaning solution in the cap to just before it overflows.

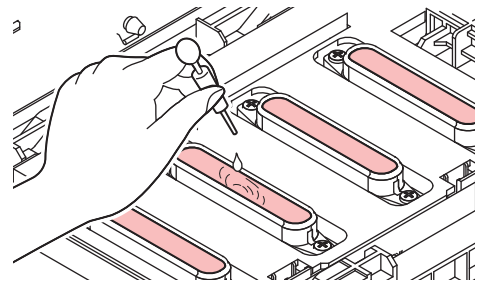

**7** Close the front cover, and press the **ENTER** key.

## When the Machine Is Not Used for a Long Time

When the machine is not going to be used for a week or more, use the cleaning function for custody to clean the head nozzles and ink discharge passage. After this, keep the machine in custody.

**Important!**

- Use the machine with always turning "ON" the main power. The function preventing nozzle clogging operates automatically to protect the head of the nozzle.
- The head nozzle may result in nozzle clogging if the main power switch is left OFF for a long time.

### Check the items on the right beforehand.

#### Is [NEAR END] or [INK END] displayed?

- The cleaning solution or ink is absorbed when the nozzles are washed.

At this time, if the state of "no ink" or "almost no ink" is detected, the nozzle washing operation cannot start.

- Replace the ink IC chip with another from which the state of "almost no ink" or "no ink" is not detected.



- When the warning messages "Check waste ink" are indicated, check the waste ink tank, and operate it, referring to P.4-17 "If a Waste Ink Tank Confirmation Message Appears" according to the situation.

# 1

Press **FUNC1 (MENU)** → **ENTER** in LOCAL.

- MAINTENANCE MENU will be displayed.

# 2

Press the **ENTER** key.

- "STATION" will be selected.

# 3

Press **▲ ▼** to select "CUSTODY WASH", and press the **ENTER** key.

- Carriage will move onto the platen.

# 4

When "WIPER CLEANING" appears on the display, open the front cover.

# 5

Clean the wiper and the bracket.

- (1) Open the front cover then pull out it by holding projections at both ends of the wiper.
- (2) Clean the wiper and bracket with a clean stick dipped in cleaning solution for maintenance. Wipe off so that cleaning solution for maintenance will not remain.

- (3) Insert it in the original position by holding the projections at both ends of the wiper.

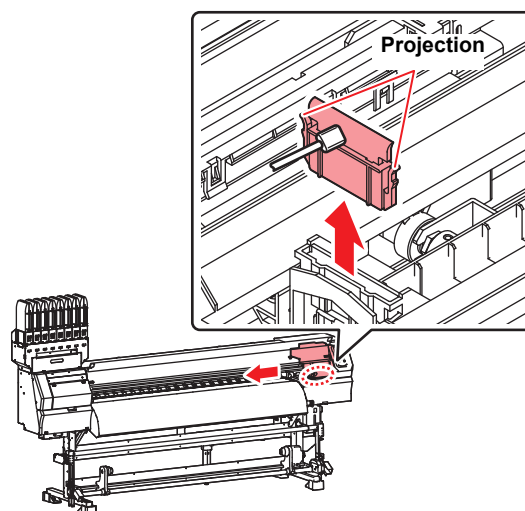

# 6

Press the **ENTER** key.

**Important!**

- Until wiper cleaning is completed, [COMPLETED (NEXT): ENT] is displayed on the screen. After the work up to the step 5 is completed, press the [ENTER] key. If you press the [ENTER] key before cleaning is completed, the machine moves to the next washing procedure.

# 7

Clean the cap rubber.

- Wipe off the ink sticking to the cap rubber with a clean stick dipped in maintenance solution for maintenance.
- Wipe off so that maintenance solution for maintenance will not remain.
- At this time, the discharge passage is cleaned automatically.

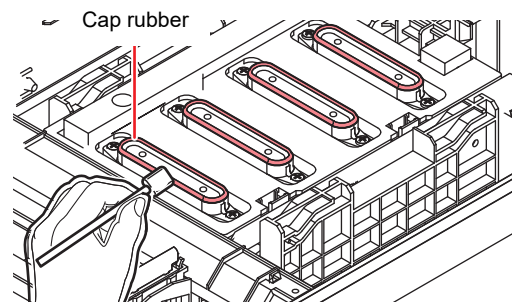

**Important!**

- After cleaning the cap rubber, check to make sure the cap slider is not tilted. If it is tilted, move the slider block left and right to fix its tilt.

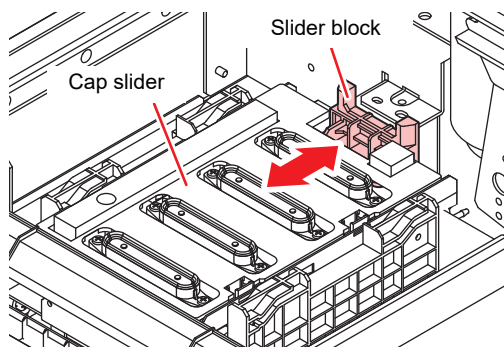



**8** Close the front cover and press the **ENTER** key.

**9** Fill up the cap with cleaning solution for maintenance.

- If the cleaning solution cartridge is usable, maintenance solution is automatically filled.
- When the cap is filled with cleaning solution, the display will prompt you to check the cleaning solution.

**Important!**

- If the front cover is not closed, the cleaning solution will not be automatically filled. If the front cover is open, be sure to close it.



- If the cleaning cartridge is not valid, the cleaning solution will not be automatically filled to the cap. Open the front cover and use a dropper to fill the maintenance cleaning solution in the cap to just before it overflows. Once the cleaning solution is full, begin from Step 11.

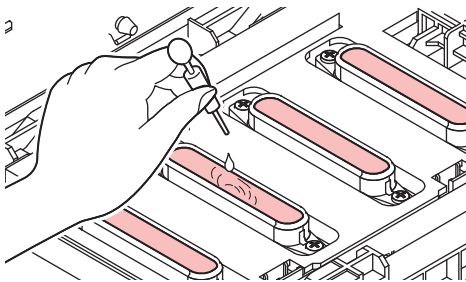

**10** If a message is displayed, open the front cover and check the amount of cleaning solution in the cap.

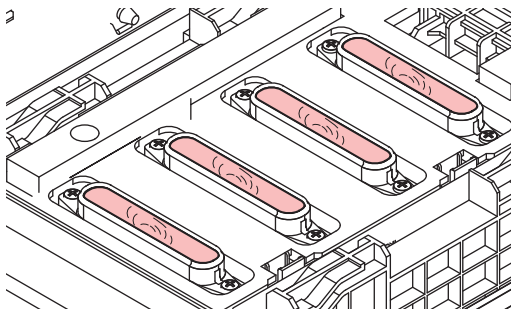

**Important!**

- If the solution does not fill up the cap, use a dropper to fill the maintenance cleaning solution in the cap to just before it overflows.

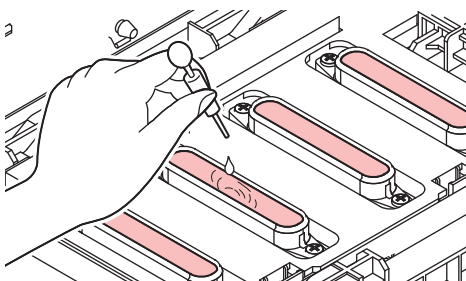

**11** Close the front cover, and press the **ENTER** key.

**12** Press **▲** **▼** to set the time for the cleaning solution to be left as it is.

- Set Value: 1 to 99 min (by the unit of 1 min)

**13** Press the **ENTER** key.

- The nozzles are washed.
- When the nozzles have been completely washed, the head moves to the maintenance position.

**14** Fill up the cap with cleaning solution for maintenance.

- If the cleaning solution cartridge is usable, maintenance solution is automatically filled.

**Important!**

- If the front cover is not closed, the cleaning solution will not be automatically filled. If the front cover is open, be sure to close it.



- If the cleaning cartridge is not valid, the cleaning solution will not be automatically filled to the cap. Open the front cover and use a dropper to fill the maintenance cleaning solution in the cap to just before it overflows. Once the cleaning solution is full, begin from Step 16.

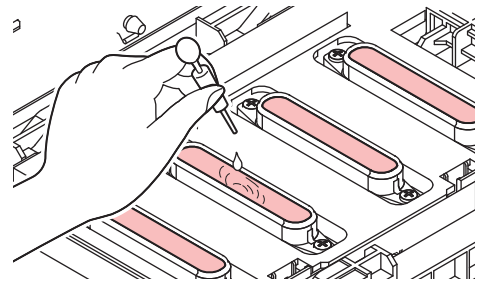

**15** If a **END** message is displayed, open the front cover and check the amount of cleaning solution in the cap.

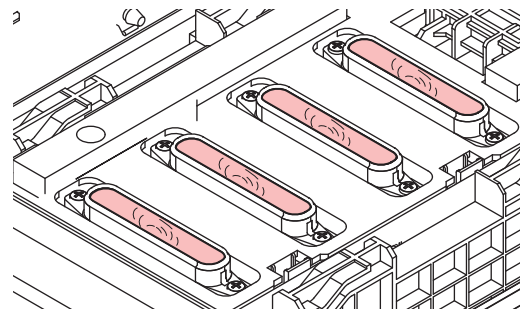

**Important!**

- If the solution does not fill up the cap, use a dropper to fill the maintenance cleaning solution in the cap to just before it overflows.

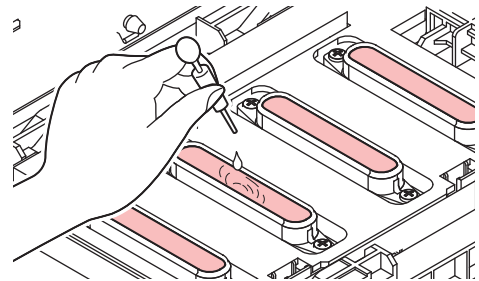

**16** Close the front cover and press the **ENTER** key.

- After its initial operation, the machine returns to step2.

## Cleaning the Ink Head and the Area around It

Because the ink head employs a very precise mechanism, due care needs to be taken when it is cleaned.

Using a clean stick, etc., rub off gelatinous ink or dust that may stick to the lower part of the slider and the area around the ink head. In doing so, never rub the nozzles of the head.

### Tools required for cleaning

• Clean stick (SPC-0527)	• Gloves
• Safety glasses	



- Be sure to wear the included safety glasses and gloves when cleaning the area around the ink head. Otherwise, you may get ink in your eyes.
- The ink contains organic solvent. If you get the ink on your skin or in your eyes, wash it away with plenty of water immediately.

1

Press **FUNC1 (MENU)** → **ENTER** in LOCAL.

- MAINTENANCE MENU will be displayed.

2

Press the **ENTER** key twice.

- "CARRIAGE OUT" will be selected.

3

Press **▲** **▼** to select "HEAD MAINTENANCE", and press the **ENTER** key.

- Carriage will move to the left end of this machine.

4

Open the maintenance cover.

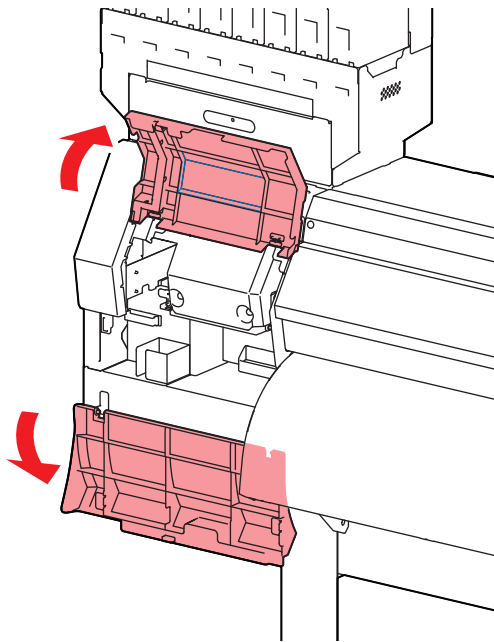

5

Wipe ink sticking to the side of the head off with a clean stick.

- Never rub the nozzles.

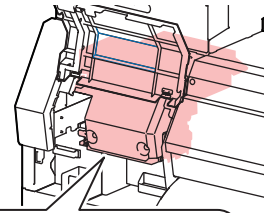

Clean the side surface of the head (shown in deep gray) with a clean stick.

The nozzle part (Never touch it.)

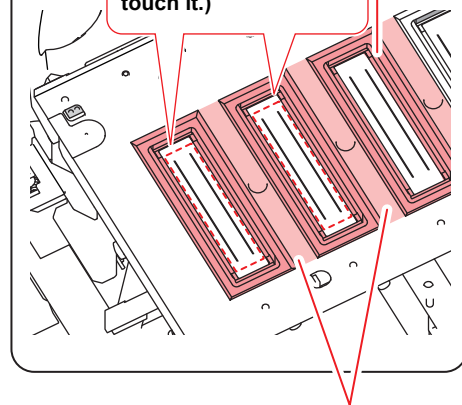

Clean with a clean stick or a waste cloth.

6

Press the **ENTER** key after the cleaning.

7

Close the maintenance cover, and press the **ENTER** key.

- After its initial operation, the machine returns to LOCAL.

# Nozzle Recovery Function

NOZZLE RECOVERY: When nozzles missing can not be improved at specific points, other good nozzles can be used as alternatives for printing.

- 1** Press **FUNC1 (MENU)** → **ENTER** in **LOCAL**.
  - MAINTENANCE MENU will be displayed.
- 2** Press **▲▼** to select **“NOZZLE RECOVERY”**, and press the **ENTER** key.
- 3** Press the **ENTER** key twice.
  - Printing of the nozzle pattern will start.
  - Select **“ENTRY”** then **“Move to select of the Nozzle line (Step 4) without drawing a pattern”**

### Overhead view

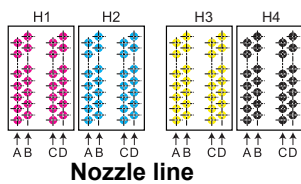

### Nozzle pattern of Head 1

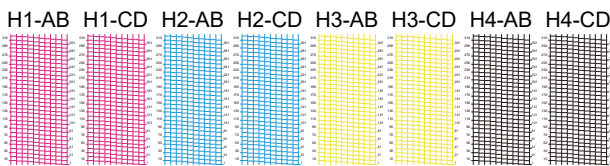

**Important!** • When using leaf media, set a media of more than A3 size put horizontally. If a media with narrow width is set, printing will only be conducted to midway.

- 4** Select the Nozzle line that needs **NOZZLE RECOVERY** by pressing **▲▼**, and press the **ENTER** key.

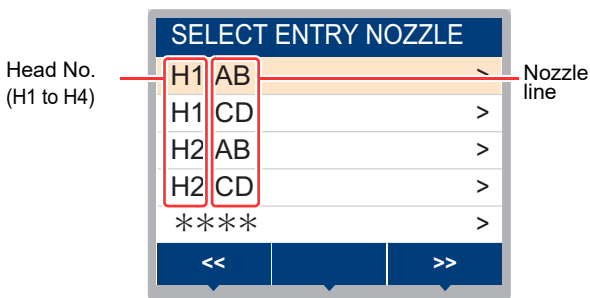

- 5** Register the Nozzle number that needs **NOZZLE RECOVERY** and press the **ENTER** key.
  - (1) Select the registration number from 1 to 10 by pressing **▲▼** and press the **ENTER** key.
  - (2) Register the nozzle number that needs recovery by pressing **▲▼** and press the **ENTER** key.

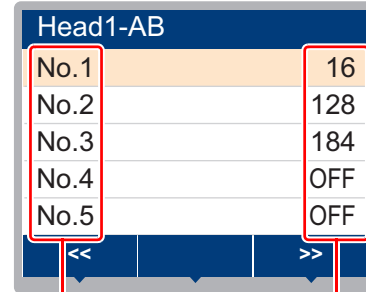

Recovery nozzle No. or OFF

Registration number : 1 to 10

### Example of nozzle to be recovered

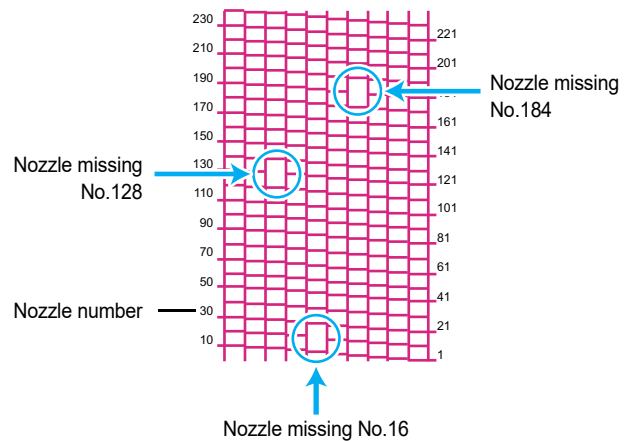

Registration number	Recovery Nozzle No.	State
1	16	Target for nozzle recovery
2	128	Target for nozzle recovery
3	184	Target for nozzle recovery
4	OFF	No registration
5	OFF	No registration

- 6** Press the **END/POWER** key several times to end the setting.

**Important!** • Up to 10 nozzles can be registered per 1 nozzle line.  
 • Even if you use this function, time required for drawing does not change.  
 • When printing has been done with the lowest path, nozzle recovery is not reflected.

## Reset the set value

- 1 Press **FUNC1** (MENU) → **ENTER** in LOCAL.  
• MAINTENANCE MENU will be displayed.
- 2 Press **▲▼** to select “NOZZLE RECOVERY”, and press the **ENTER** key.
- 3 Press **▲▼** to select “RESET”, and press the **ENTER** key.
- 4 Press **▲▼** and **FUNC1** (PAGE>) **FUNC3** (<<) to select the Nozzle line that need reset, and press the **ENTER** key.  
• A reset confirmation message will be displayed.
- 5 Press the **ENTER** key.
- 6 Press the **END/POWER** key several times to end the setting.

## Check the condition for which nozzle recovery cannot be performed

- 1 Press **FUNC1** (MENU) → **ENTER** in LOCAL.  
• MAINTENANCE MENU will be displayed.
- 2 Press **▲▼** to select “NOZZLE RECOVERY”, and press the **ENTER** key.
- 3 Press **▲▼** to select “CHECK”, and press the **ENTER** key.  
• Judgement Condition input screen will be displayed.

Judgement Condition	
Resolution	720 x 720
PASS	8
Scan Speed	NORMAL
MAPS 4	>
OVER PRINT	1

- 4 Adapt each item of the judgment conditions to your current state.
  - (1) Press **▲▼** to select the setting item, and press the **ENTER** key.
  - (2) Press **▲▼** to select the setting value, and press the **ENTER** key.
  - (3) Repeat steps (1) and (2), and set all of the items.

- 5 Press **FUNC2**.
  - Begin to check if nozzle recovery at the set printing conditions can be done.
  - When the check is completed, the judgment result is displayed on the screen.

If the nozzle recovery possible

Judgement result	
Judgement result	OK

If the nozzle recovery is not possible

Judgement result	
Judgement result	NG
HEAD1-AB	1
HEAD1-CD	0
HEAD2-AB	0
HEAD2-CD	2
Judgement result	
HEAD3-AB	1
HEAD3-CD	0
HEAD4-AB	0
HEAD4-CD	0

Head no. and nozzle line

The number of nozzles that can not be recovered.

- 6 Press **END/POWER** several times to end the setting.

## Enabling or disabling nozzle recovery during a test print

To enable the nozzle recovery function during a test print (☞ P.2-16), turn the following settings “ON”, and register the numbers of the nozzles for recovery in “Nozzle Recovery Function” on P.4-13.

- 1 Press **FUNC1** (MENU) → **ENTER** in LOCAL.  
• MAINTENANCE MENU will be displayed.
- 2 Press **▲▼** to select “NOZZLE RECOVERY”, and press the **ENTER** key.
- 3 Press **▲▼** to select “TEST PRINT”, and press the **ENTER** key.
- 4 Press **▲▼** to select ON/OFF, and press the **ENTER** key.
- 5 Press the **END/POWER** key several times to end.

# Automatic Maintenance Function

To use this machine comfortably, you can set various maintenances to be performed automatically.

Here, set performing intervals of various automatic maintenances.

You can prevent troubles such as ink clogging by performing automatic maintenance periodically (automatic maintenance function).

For the auto maintenance functions, the following items can be set:

- Important!**
  - When you perform maintenance manually, after manual maintenance is completed and when time set with the automatic maintenance function has passed, maintenance starts automatically.
  - If using the Automatic Maintenance Function, make sure that the maintenance washing liquid is set. If the maintenance washing liquid is not set, tube washing operation will not be regularly conducted and the passage could be clogged.

Function name	Descriptions
REFRESH	The interval between each refreshing operation is set.
PUMP TUBE CLEANING	The activation interval for tube washing is set.
CLEANING (Interval)	The interval between each cleaning operation is set.
CLEANING (Type)	The cleaning type is set.
NOZZLE WASH	Setting for the action can not be changed.

- Important!**
  - If the "Check waste ink" warning message is displayed, the operation set in the auto maintenance function is not carried out. Perform the operations of P.4-18 "Replace the waste ink tank with another" if required.
  - When the power switch on the front of the machine is turned off, check the waste ink tank.

## Setting the Refreshing Intervals

The interval between each operation of ejecting a small amount of ink from the nozzles to prevent nozzle clogging is set.

- 1** Press **FUNC1 (MENU)** → **▼** → **ENTER** in LOCAL.
  - MAINTENANCE MENU will be displayed.
- 2** Press **▲▼** to select "AUTO MAINTENANCE", and press the **ENTER** key.
- 3** Press the **ENTER** key.
  - "REFRESH" will be selected.
- 4** Press **▲▼** to set the refreshing interval, and press the **ENTER** key.
  - **Set value** : The set value will differ according to the ink type being used.
- 5** Press the **END/POWER** key several times to end the setting.

## Setting the Tube Wash Intervals

For setting the interval at which washing of the ink tubes will be carried out, in order to prevent ink clogging due to coagulation of ink inside the ink tubes.

- Important!**
    - In order to perform tube washing with the Automatic Maintenance Function, the maintenance washing liquid needs to be set. If the maintenance washing liquid is not set, tube washing operation will not be regularly conducted and the passage could be clogged.
- 1** Press **FUNC1 (MENU)** → **▼** → **ENTER** in LOCAL.
    - MAINTENANCE MENU will be displayed.
  - 2** Press **▲▼** to select "AUTO MAINTENANCE", and press the **ENTER** key.
  - 3** Press **▼**, and press **ENTER** .
    - "PUMP TUBE CLEANING" will be selected.
  - 4** Press **▲▼** to set the tube washing interval, and press **ENTER** .
    - **Set value** : The set value will differ according to the ink type being used.
  - 5** Press the **END/POWER** key several times to end the setting.

## Setting the Cleaning Intervals and Type

The cleaning type and the interval between each cleaning operation are set.

- 1** Press **FUNC1 (MENU)** → **▼** → **ENTER** in LOCAL.
  - MAINTENANCE MENU will be displayed.
- 2** Press **▲▼** to select "AUTO MAINTENANCE", and press the **ENTER** key.
- 3** Press **▼** several times to select "Interval" or "Type", and press the **ENTER** key.
- 4** Press **▲▼** to select a set value, and press the **ENTER** key.
  - **Set value** : The set value will differ according to the ink type being used.
  - **Set value of type** : NORMAL/ HARD
- 5** Press the **END/POWER** key several times to end the setting.

## Suspend the nozzle cleaning

When you want to work as such a printing during the nozzle cleaning, you can interrupt the nozzle cleaning.



- If the nozzle cleaning is interrupted, run the head cleaning without waiting for the configured cleaning time.

### 1 Press the **END/POWER** key during the nozzle cleaning implement.

- Display the selection screen of the nozzle cleaning stop.

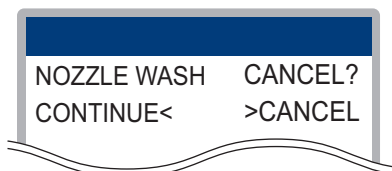

### 2 Press **▶** to select "CANCEL".



- If you want to continue the nozzle cleaning, please select [**◀**](CONTINUE).

## Fill up Ink

Supplies ink to correct nozzle clogging.

### 1 Press **FUNC1 (MENU)** → **▼** → **ENTER** in LOCAL.

- MAINTENANCE MENU will be displayed.

### 2 Press **▲** **▼** to select "FILL UP INK", and press the **ENTER** key.

### 3 Press **▲** **▼** to select the filling head, and press the **ENTER** key.

### 4 Press the **ENTER** key.

- Ink is supplied automatically.

### 5 Press the **END/POWER** key several times to end the setting.

## Replacing consumables

Use the supply items to replace filters and parts if they are excessively dirty, damaged, or deformed.

To order replacement consumable items, contact your local dealer or our service office.

For more information on other consumable items, refer to our website. <https://mimaki.com/supply/inkjet.html>

## Replacing the wiper

The wiper is consumable. When the display indicates the warning message "Replace a WIPER" it is necessary to check and replace the wiper, immediately replace the wiper with a new one.

Also, wipe ink sticking to the lower surface of the slider off.



- When the warning message for replacing wiper is shown, confirm whether there is no damage and fuzz at the top edge of the wiper film. If there is no damage on the top edge of the wiper film, it is possible to use the wiper continuously without replacing it.
- A cleaning wiper is an option. Buy one through the dealer in your region or at our service office.

### 1 Press **FUNC1 (MENU)** → **▼** → **ENTER** in LOCAL.

- MAINTENANCE MENU will be displayed.

### 2 Press the **ENTER** key.

- "STATION" will be selected.

### 3 Press **▲** **▼** to select "WIPER EXCHANGE", and press the **ENTER** key.

**4** Press the **ENTER** key.

- The carriage will move onto the platen.

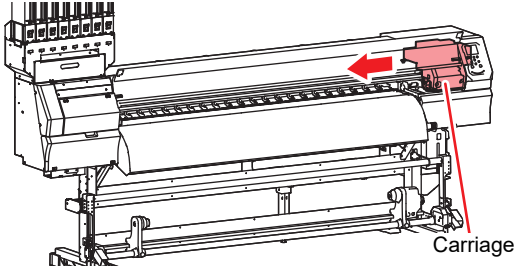
**5** Remove the wiper.

- Pull out the wiper by holding the protrusions at its both ends.

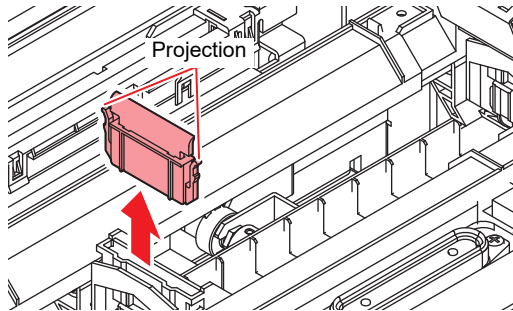
**6** Insert a new wiper.

- Insert the wiper by holding the protrusions at its both ends.

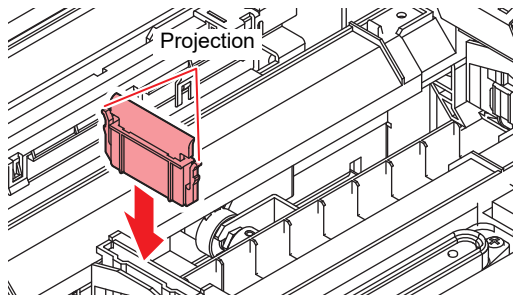
**7** Close the front cover, and press the **ENTER** key.

- After its initial operation, the machine returns to LOCAL.

**If a Waste Ink Tank Confirmation Message Appears**

Ink used in head cleaning, etc. is stored in the waste ink tank on the lower right side of the machine. This machine counts the accumulated amount of discharged ink. When that reaches a specified amount, the machine displays a confirmation message. (When this message is displayed, consider the replacement of the waste ink tank.)



- The message is displayed when it reaches 80% (1.6L) of the 2L tank.

**Confirmation Message in LOCAL****1** The warning message “Check waste ink” is displayed.**2** Check the state of the waste ink tank

- For any difference between the displayed level and the actual level of discharge amount, carry out the operations described in and after step 3.
- If there is no difference between the displayed level and the actual level, and if you replace (dispose of) the waste ink tank, carry out the procedure described in “Replace the waste ink tank with another” (P.4-18)

**3** Press **FUNC1 (MENU)** → **ENTER** in LOCAL.

- MAINTENANCE MENU will be displayed.

**4** Press **ENTER** to select “REPLACE WasteInkTank”, and press the **ENTER** key.**5** If the amount of waste ink needs to be adjusted, press the **ENTER** key.**6** Press **ENTER** to adjust the level, and press **ENTER**.**7** Press the **ENTER** key.

## Replace the waste ink tank with another

When the waste ink tank becomes full, carry out the procedure below to replace the waste ink tank, and in the Maintenance menu, set 0% for waste ink tank information. If you replace the waste ink tank before the waste ink tank confirmation message is displayed (before the 2L tank is 80% (1.6L) full), carry out the same procedure to replace the waste ink tank.

- 1** Press **FUNC1** (**MENU**) → **ENTER** in **LOCAL**.  
 • MAINTENANCE MENU will be displayed.

- 2** Press **▲** **▼** to select “**REPLACE WastInkTank**”, and press the **ENTER** key.  
 • Waste ink tank information is displayed.

- 3** Press **▲** **▼** to adjust the level, and press the **ENTER** key.

- 4** Press the **ENTER** key.  
 • The waste ink tank amount that is managed in this machine will be reset.

- 5** Pull the waste ink tank stopper to open to the front.

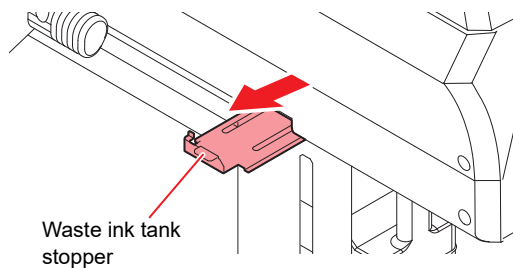

- 6** Pull it frontward to remove by holding the waste ink tank handle.

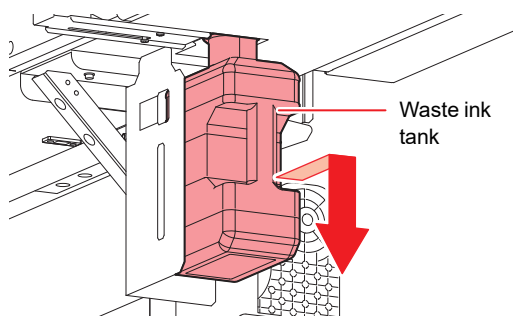

- Put a cap on the waste ink tank removed.

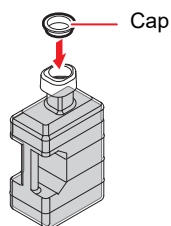

- 7** Replace the waste ink tank.

- (1) Prepare a new waste ink tank (SPC-0117) or discard waste ink from current waste ink tank.  
 (2) Insert the waste ink tank by holding a handle of the tank.

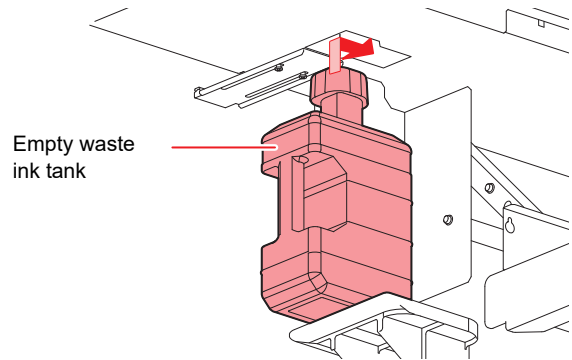

- Waste ink is equivalent to waste oil of industrial waste. Request an industrial waste disposal company for disposal of waste ink.

- 8** Close the waste ink tank stopper.

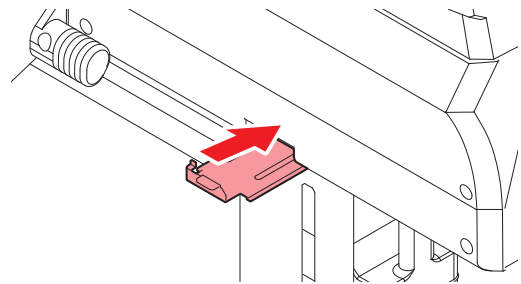

- 9** Press the **ENTER** key.

- The ink discharging amount that is controlled by the machine is reset and the message is cancelled.



## Replacing the Cutter Blade

The cutter blade is consumable. When the cutter blade gets dull, replace it with a new one (SPA-0107).



- The blade is sharp. Be careful not to hurt yourself or anyone else.
- Store the cutter blade in a place that is out of the reach of children. In addition, dispose of used cutter blades according to regional laws and regulations.



- When replacing the cutter blade, it is recommended to place a sheet of paper under the cutter blade. This will help pick up the cutter blade if it drops.

**1** Press **FUNC1 (MENU)** → **ENTER** in **LOCAL**.

- MAINTENANCE MENU will be displayed.

**2** Press the **ENTER** key twice, and open the front cover.

- The carriage moves onto the platen.

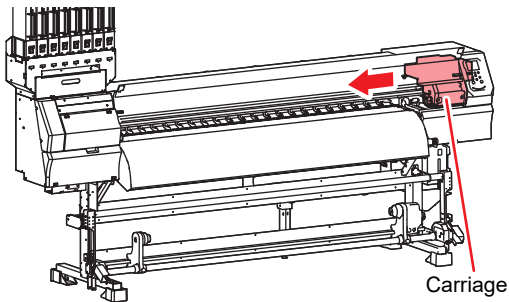

**3** Replace the cutter unit by the carriage.

- (1) Loosen the screw of the cutter unit.
- (2) Remove the cutter unit.
- (3) Mount a new cutter unit.
- (4) Fasten the screw of the cutter unit to secure the cutter unit.

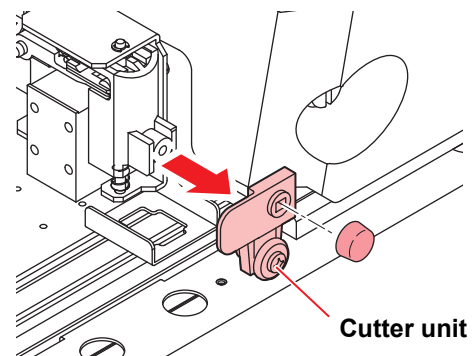
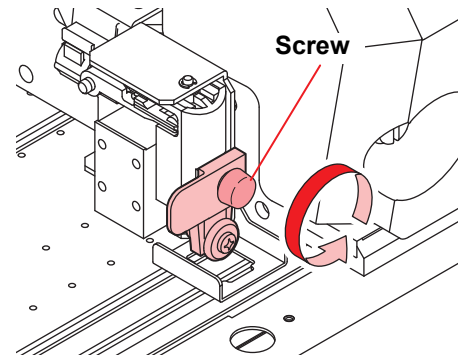

**4** Close the **FRONT** cover.

**5** Press the **ENTER** key.

## Replacing the Spout Rubber

Install the spout rubber in an eco case in order to reduce ink leakage from the 2L ink pack.

The spout rubber is a supplied part. (SPA-0317: Set of 8 Rubber stopper 2L for case)

The replacing timing sign of the spout rubber will be shown about once every half-year. Please replace the spout rubber when you see the sign on the display.



- When exchanging 2L ink pack, be sure to wear the included safety glasses and gloves. Ink may spatter and get in your eyes accidentally.



- Replace all eight spout rubber as a set at the same time.
- Depending on the usage environment and usage conditions, the spout rubber may deteriorate within half a year. If the gap in the center expands as shown in the picture, please replace it regardless of if there is a warning message.



The beginning of spout rubber



It is available to use



It is necessary to replace



- Reset the counter according to the following procedures if replacing any time other than when the warning is displayed

- (1) Press the **[FUNC1]** key in LOCAL to select "INFORMATION" and press the **[ENTER]** key.
- (2) Select "USAGE" and press the **[ENTER]** key.
- (3) Press the **[FUNC3]** key
- (4) If the following appears, press the **[ENTER]** key to reset the counter.

EcoCase/SpoutRubber  
RESET? [ENT]

- 1** Open the 2L eco case.

- 2** Remove the 2L ink pack.

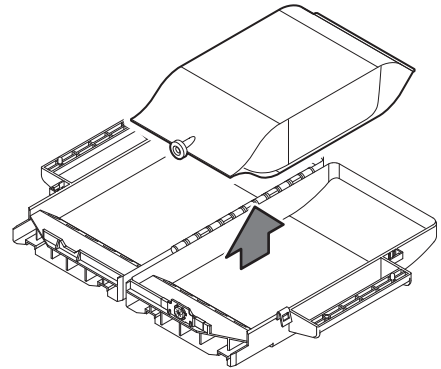

- 3** Remove the spout rubber.

- Press against the top of the spout rubber and pull it out vertically.

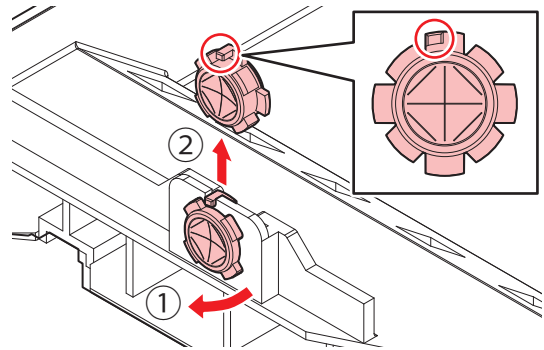

## 4 Attach the new spout rubber from outside of the eco-case.

- Insert it aligning the positioning protrusion of the spout rubber to the concave position of the eco-case.
- Be careful of the direction of the rubber when installing.
- Push the entire rubber into groove until the spout rubber fits evenly.
- Bending the entire spout rubber makes it easier to insert from the outside of the case.

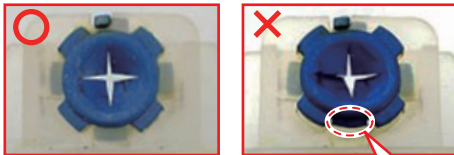
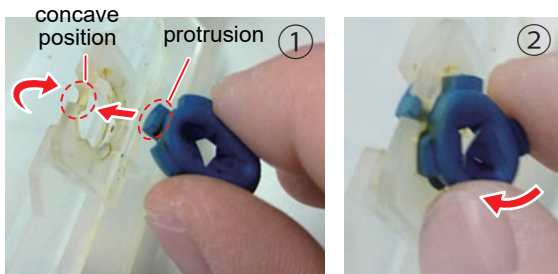

The rib don't fit. If it is not seated in the groove correctly, the spout rubber will be damaged.

## 5 Moisten the surface of the spout rubber with maintenance solution sufficiently before inserting.

- Inserting the rubber into the eco-case without moistening may damage the rubber.
- In that case, use a maintenance solution that is suitable for the ink type.

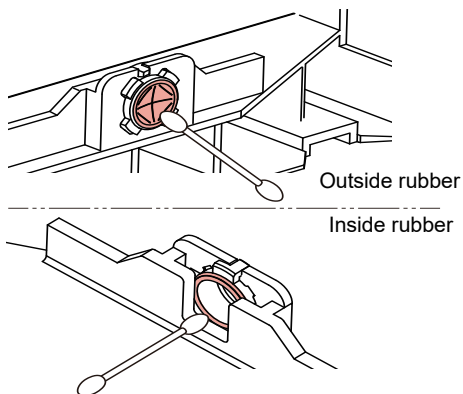

## Male Connector Absorbent for MBIS

When replacing the 2L ink pack, you can prevent dirt from entering the cradle by periodically (5 to 10 times) replacing the male connector absorbent (accessory).



- Be sure to wear the supplied safety glasses and gloves when replacing the male connector absorbent.



- When the accessories are finished, please purchase from your local dealer or our sales office. (PN:SPA-0625)

### 1 Push down the lever attached to the cradle, and remove the 2L eco-case.

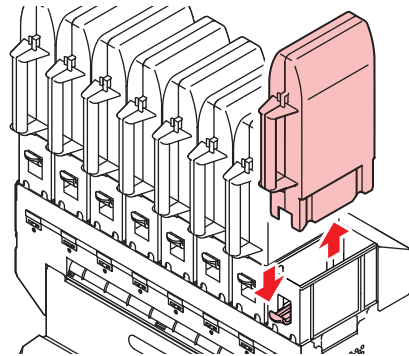

### 2 Remove the male connector absorbent.

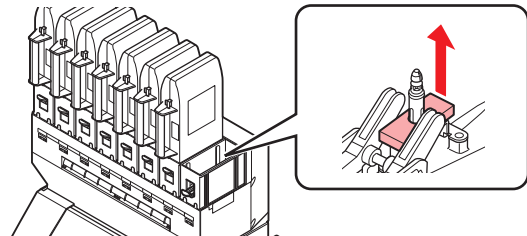

### 3 Insert the new male connector absorbent.

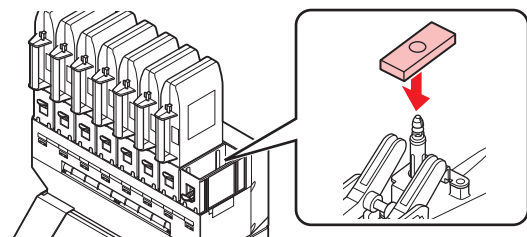

**4**

Install the 2L eco-case.

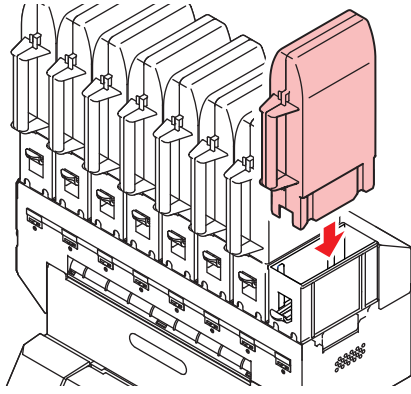

# Chapter 5

## Troubleshooting



### This chapter

describes the corrective measures to be taken for a phenomenon suspected to be trouble and the procedures to clear the error number displayed on the LCD.

Troubleshooting .....	5-2
Power does not turn on .....	5-2
The machine does not start printing .....	5-2
Media get jammed / media is soiled .....	5-2
The heater's temperature will not rise to the set level .....	5-3
Image quality is poor .....	5-3
Nozzle is clogged .....	5-3
Ink IC warning appears.....	5-3
When the ink leakage occurs .....	5-4
Warning / Error Messages .....	5-5
Warning messages.....	5-5
Error messages .....	5-8

# Troubleshooting

Take appropriate actions as described below before taking the trouble as a failure.

If still the problem is not solved after troubleshooting, contact your dealer or an office of MIMAKI.

## Power does not turn on

In most cases, this is due to improper connection of the power cable for the machine or computer. Check that the power cable is connected properly.

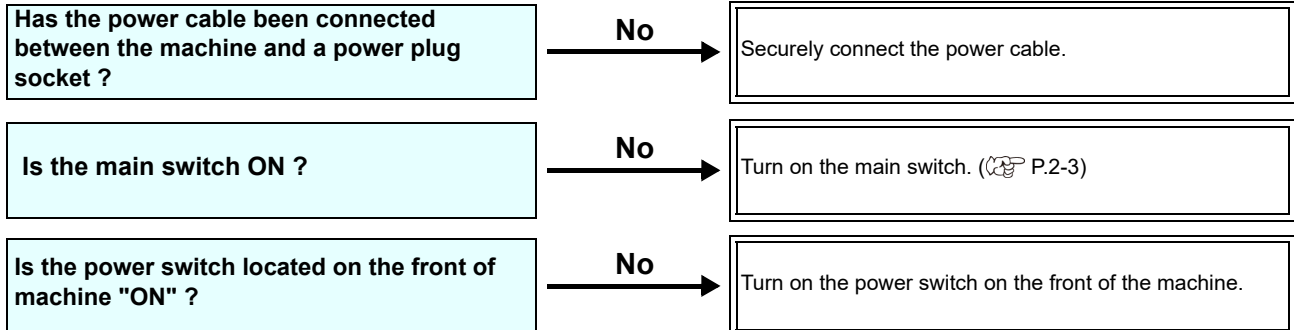

## The machine does not start printing

This occurs when the data is not being transmitted to the machine properly.

It can also occur when the printing function does not work properly or the media is not set correctly.

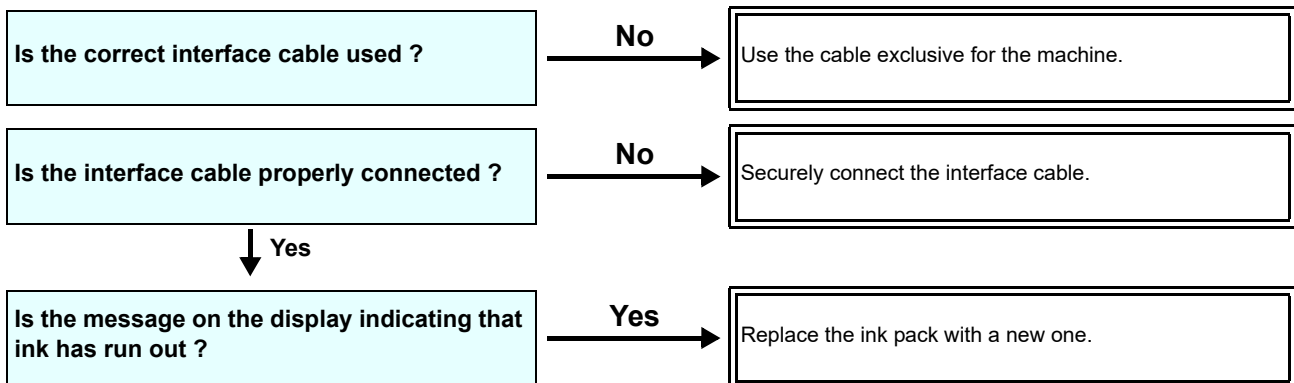

## Media get jammed / media is soiled

Media jamming or stained media is considered to be due to the use of an unsuitable media or improper setting of media.

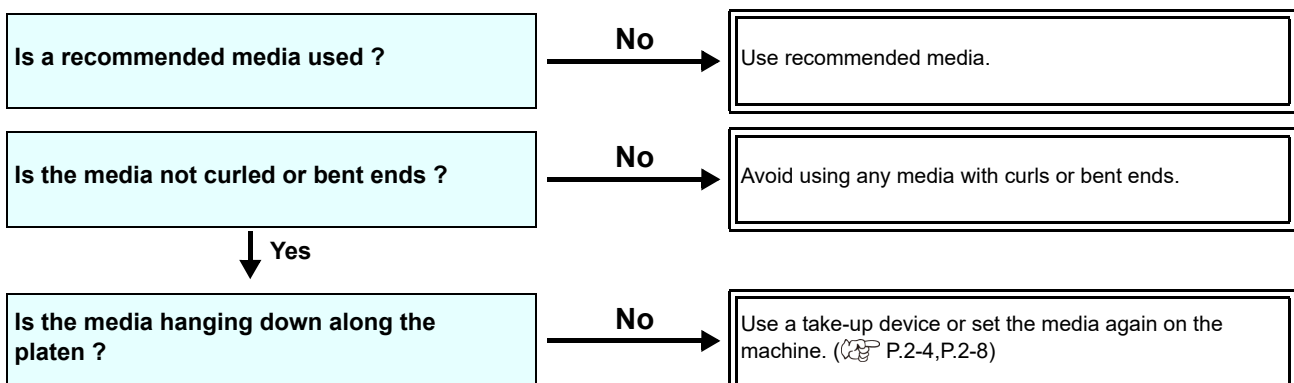

## The heater's temperature will not rise to the set level

Check the basic operation.

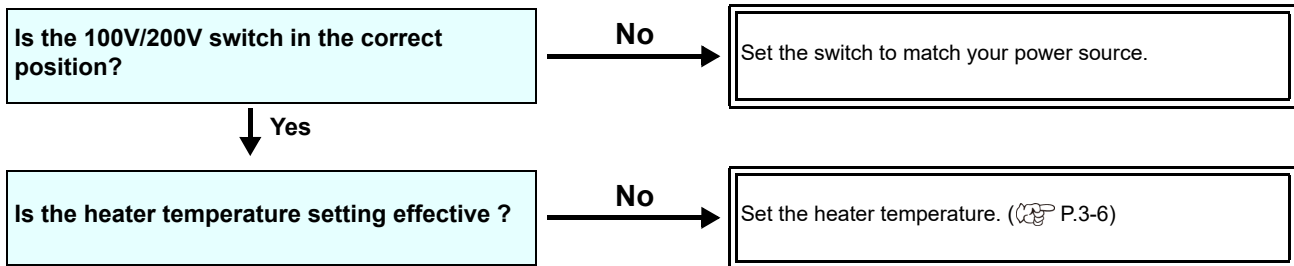

## Image quality is poor

This section describes the corrective actions to be taken in case the image quality is not satisfactory.

Take remedy for particular problems with image quality. If the remedy does not work, contact your dealer or an office of MIMAKI.

Phenomenon	Measures
White lines / blur / dark stripes (in the direction of travel of the heads)	(1) Execute the head cleaning. (P.2-17) (2) Perform maintenance of the inside of the station. (P.4-6) (3) Execute the [FEED COMP.] function. (P.3-5) (4) If any pieces of paper or dust is attached on the path of the heads such as media press, remove it.
Characters are double- or triple-printed in the media feed direction	(1) Execute the [FEED COMP.] function. (P.3-5)
Disagreement in print positions between outward trip and homeward trip	(1) Execute the [DROP POSITION] function. (P.3-6)
Ink drops falling on media during printing	(1) Execute the wiper cleaning. (P.4-6) (2) Execute the ink cap cleaning. (P.4-6) (3) Clean around the head. (P.4-12) (4) Execute the head cleaning [NORMAL]. (P.2-17) (5) Set the INTERVAL WIPING operation. (P.3-11)

## Nozzle is clogged

When nozzle clogging is not dissolved even after the head cleaning referring to P.2-17, make sure the following operations.

- Wash the head nozzle by the operations of P.4-7.
- Wash the head nozzle surface by the operations of P.4-12.
- Recovery the nozzle by the operations of P.4-13.

## Ink IC warning appears

If an ink IC trouble is detected, the cartridge LED "red" is lit, and a warning message appears.

None of printing, cleaning and all the other operations that use ink is available.

In this case, replace the ink pack in question immediately.



- Once cartridge trouble is displayed, do not leave the ink pack without replacing it for a long time; otherwise, the machine will lose the nozzle clogging prevention function.  
If nozzles are clogged, the machine must be repaired by MIMAKI's service engineer.

## Displaying the description of ink IC trouble

The contents of IC error are confirmable by the following operations.

- 1 Press the **ENTER** key in LOCAL.
- 2 Press the **ENTER** key.

## When the ink leakage occurs

In case of ink leakage, please turn off the main power, unplug the power cable and contact your local distributor, our sales office, or service center.



## Warning / Error Messages

If some trouble occurs, the buzzer sounds and the display shows a corresponding error message. Take an appropriate remedy for the displayed error.

### Warning messages

#### Errors when performing operations

Message	Cause	Solution
INVAILD OPERATION :MEDIA UNDETECT	Operation cannot be performed because no media is detected.	• Execute after media is detected.
INVAILD OPERATION :MOTOR POWER OFF	The motor is OFF after the cover was opened etc.	• Return to LOCAL and execute the operation after completion of initialization.
INVAILD OPERATION INK ERROR	An ink error occurred.	• Execute the operation after replacing with a new ink pack.
INVAILD OPERATION COVER OPEN	The front cover or the maintenance cover is opened.	• Execute the operation after closing the cover.
INVAILD OPERATION DATA REMAIN	Data was received.	• Execute the operation after executing data clear. (P.2-19)

#### Message displayed in LOCAL

Message	Cause	Solution
Can't print/cartridge	Multiple ink errors (unusable ink) have occurred, making it impossible to feed ink (printing and cleaning, etc.).	Replace with a new ink pack.
Check waste ink	The waste ink tank count has exceeded the prescribed amount.	Check the amount of waste ink in the waste ink tank. Conduct maintenance and waste ink tank replacement, and reset the amount of waste ink.
Replace WIPER	The used count of wiper has exceeded the prescribed number.	Execute maintenance, station maintenance and wiper exchange and replace the wiper.
HEATER Temp. error Powered off	Displayed when power is forcibly turned OFF and restarted after occurrence of "ERROR 710 heater temp error".	When displaying again, contact your local distributor, our sales office, or service center.
NO MEDIA	No media is set. Or, the sensor is faulty.	Set the media. If the same error message still appears after setting the media, contact your local distributor, our sales office, or service center.
DATA REMAIN	Print data is received in LOCAL.	Shift to REMOTE and execute printing. Or, execute data clear and cancel printing.
MACHINE TEMP./H ***°C	Stable printing cannot be done because temperature in the installed environment (printer) is too high.	Adjust the ambient temperature to within the specified scope (20°C to 35°C).
MACHINE TEMP./L ***°C	Stable printing cannot be done because temperature in the installed environment (printer) is too low.	

Message	Cause	Solution
Wash liquid cartridge none	The maintenance washing liquid cartridge is not set. Wiper washing and pump tube washing cannot be executed. (Auto maintenance operation)	Set the maintenance washing liquid cartridge.
Wash liquid end	There is no remaining maintenance washing liquid. Wiper washing and pump tube washing cannot be executed. (Auto maintenance operation)	Replace with a new washing liquid cartridge.
NCU SENSOR LEVEL LOW	The NCU sensor sensitivity is falling.	Replacement of the NCU is recommended. Contact your local distributor, our sales office, or service center.
NCU Sens Adj Err H	The sensitivity level of the sensor cannot be adjusted.	
NCU Sens Adj Err L		
Nozzle Missing Print Stopped	Because the nozzle check found nozzles missing, printing was stopped.	Perform head cleaning (☞ P.2-17) and deal with the nozzles clogging (☞ P.5-3).
NCU FLUSH POS Nozzle check OFF	Because an NCU-related error occurred during nozzle check, printing was stopped and the nozzle check function was turned OFF.	• Take steps according to the explanation for "ERROR 655 / NCU FLUSH POS".
NCU CENTER POS Nozzle check OFF		• Take steps according to the explanation for "ERROR 654 / NCU CENTER POS".
NCU SN ADJUST Nozzle check OFF		• Take steps according to the explanation for "ERROR 656 / NCU SN ADJUST".
NCU NZK CHK (HW) Nozzle check OFF		• Take steps according to the explanation for "ERROR 652 / NCU NZK CHK (HW)".
NCU NZK CHK (MARK) Nozzle check OFF		• Take steps according to the explanation for "ERROR 653 / NCU NZK CHK (MARK)".
NCU CONNECT	The NCU unit is not connected. The nozzle check function cannot be used.	• Turn off the power on the machine and turn it on after a while. When displaying again, contact your local distributor, our sales office, or service center.
REPLACE NCU	The NCU sensor sensitivity is too low to correctly judge nozzle missing. The nozzle check function cannot be used.	• NCU replacement is necessary. • Contact your local distributor, our sales office, or service center.
REPLACE NCU INK PAD	The NCU ink pad is full.	• It is necessary to replace the NCU ink pad. • Contact your local distributor, our sales office, or service center.
NCU ERROR Nozzle check OFF	Because an NCU-related error occurred during nozzle check, printing was stopped and the nozzle check function was turned OFF.	• Contact your local distributor, our sales office, or service center.
ADJUST HEAD HEIGHT	The head height setting saved in the machine and the current head height do not match.	• Set the head height. (☞ P.2-4)

## Ink Error

Ink error is displayed also in the local guidance. (☞ P.3-29)

Message	Cause	Solution
WRONG INK IC	The ink IC chip of the ink pack cannot be read normally.	<ul style="list-style-type: none"> <li>Reinsert the ink IC chip in which a warning is occurring.</li> <li>If the warning is not resolved, contact your dealer or our sales office or call center.</li> </ul>
INK TYPE	The ink type of the ink pack is different from the ink filled.	<ul style="list-style-type: none"> <li>Check the ink type of the cartridge in which a warning is occurring.</li> </ul>
INK COLOR	The ink color of the ink pack is different from the ink filled.	<ul style="list-style-type: none"> <li>Check the ink color of the cartridge in which a warning is occurring.</li> </ul>
WRONG CARTRIDGE	The usage exceeds the specified value. An error occurred in the ink IC chip information of the ink pack.	<ul style="list-style-type: none"> <li>Replace the cartridge in which a warning is occurring.</li> <li>Make sure there is no nozzle clogging (Especially, white ink).</li> </ul>
NO CARTRIDGE	An ink IC chip has not been installed in the slot.	<ul style="list-style-type: none"> <li>Insert the ink IC chip into the slot in which a warning is occurring.</li> <li>Make sure that the ink IC chip is correctly inserted.</li> <li>Turn off the power on the machine and turn it on after a while.</li> </ul> <p>If it is displayed again, contact your dealer, our sales office, or call center.</p>
INK END	The ink of the ink pack has been completely used up.	<ul style="list-style-type: none"> <li>Replace the ink pack where a warning is occurring.</li> </ul>
INK NEAR END	The ink of the ink pack has been nearly used up.	<ul style="list-style-type: none"> <li>The ink will run out shortly. Be careful.</li> </ul>
Expiration	The ink pack has expired.	<ul style="list-style-type: none"> <li>The expiration date has passed. However, it can be used until the month after next.</li> </ul>
Expiration:1MONTH	The ink pack has expired. (One month has passed since expiration)	<ul style="list-style-type: none"> <li>More than one month has passed since the expiration date. But, it can be used until the next month.</li> </ul>
Expiration:2MONTH	The ink pack has expired. (Two month has passed since expiration)	<ul style="list-style-type: none"> <li>More than two months have passed since the expiration date. Replace the ink pack in which a warning is occurring</li> </ul>
ERROR 63c INK REMAIN ZERO	The cartridge remaining amount has become 0.	<ul style="list-style-type: none"> <li>Replace the ink pack with a new one.</li> </ul>

## Error messages

When an error message is displayed, eliminate the error according to the chart below.  
When displaying again, contact your dealer or an office of MIMAKI to call for service.

Message	Cause	Solution
ERROR 108 HD THERMIS[1234]	Head temperature control is defective.	<ul style="list-style-type: none"> <li>• Turn off the power to the machine and turn it on after a while. When displaying again, contact your local distributor, our sales office, or service center.</li> </ul>
ERROR 108 HD CONNECT[1234]	An abnormality occurred in the head connection.	
ERROR 122 CHECK:SDRAM	SDRAM is defective.	
ERROR 128 HDC FIFO OVER	Head control circuit board is defective.	
ERROR 128 HDC FIFO UNDER		
ERROR 129 BATTERY EXCHANGE	The battery life end of the internal clock is detected.	<ul style="list-style-type: none"> <li>• Contact your local distributor, our sales office, or service center.</li> </ul>
ERROR 12a HDC SPEED	An error was detected in the waveform being printed.	<ul style="list-style-type: none"> <li>• Turn off the power to the machine and turn it on after a while. When displaying again, contact your local distributor, our sales office, or service center.</li> </ul>
ERROR 130 HD DATA SEQ		
ERROR 146 E-LOG SEQ	Sequential number abnormality of the event log occurred.	
ERROR 151 Main PCB V1R2	Error occurs in the power supply system of the main board.	
ERROR 152 Main PCB V2R5		
ERROR 153 Main PCB V3R3		
ERROR 154 Main PCB V05		
ERROR 157 Main PCB VTT		
ERROR 16e Main PCB V3R3B		
ERROR 15f HEAD DRIVE HOT		
ERROR 171 NEW HEAD CONNECT		
ERROR 18a Main PCB V_CORE	An error occurred in the main PCB .	
ERROR 18c Main PCB V12	An error occurred in the main PCB .	

Message	Cause	Solution
ERROR 18e FLS NOT COMP	An error was detected in the waveform being printed.	
ERROR 18f OFFSET START		
ERROR 18f OFFSET END	An error was detected in the waveform being printed.	
ERROR 1d9 Main PCB V48-1	An error occurred in the main PCB .	
ERROR 1ce SLIDER PCB V24	An error occurred in the power supply of the slider PCB.	<ul style="list-style-type: none"> <li>• Turn off the power to the machine and turn it on after a while.</li> <li>When displaying again, contact your local distributor, our sales office, or service center.</li> </ul>
ERROR 1cf SLIDER PCB V1R8		
ERROR 1de SLIDER PCB V1R2		
ERROR 1df SLIDER PCB V2R5		
ERROR 1e0 SLIDER PCB V3R3		
ERROR 1e1 SLIDER PCB V5		
ERROR 1e2 SLIDER PCB V48		
ERROR 1db Station4 PCB V48	An error occurred in the power supply of the Station IV PCB.	
ERROR 1dc Station4 PCB V24		
ERROR 1dd Station4 PCB V24-A		
ERROR 1e6 PRAM SIZE SHORTAGE	The memory size is insufficient.	
ERROR 201 COMMAND ERROR	The machine received some data other than print data. Or, an error occurred in the transmitted print data.	<ul style="list-style-type: none"> <li>• Securely connect the interface cable in position.</li> <li>• Use an interface cable conforming to the specifications.</li> </ul>
ERROR 202 PARAMETER ERROR	An error occurred in the transmitted print data.	
ERROR 206 PRINTING MODE	Unable to print with the printing conditions of the print data received.	<ul style="list-style-type: none"> <li>• Check the output conditions of the print data in the RIP software.</li> <li>• Check the profile.</li> <li>• When displaying again, contact your local distributor, our sales office, or service center.</li> </ul>

Message	Cause	Solution
ERROR 304 USB INIT ERR	An error occurred in the communication of USB.	<ul style="list-style-type: none"> <li>Turn off the power on the machine and turn it on after a while.</li> <li>When displaying again, contact your local distributor, our sales office, or service center.</li> </ul>
ERROR 305 USB TIME OUT		
ERROR 307 MCFD File IF Error	An error occurred during the access to the printing condition data.	
ERROR 401 MOTOR X	An excessive load was applied to the X motor.	
ERROR 402 MOTOR Y	An excessive load was applied to the Y motor.	
ERROR 403 X CURRENT	An error due to an excessive current of the X motor was detected.	
ERROR 404 Y CURRENT	An error due to an excessive current of the Y motor was detected.	
ERROR 423 TAKE-UP TENSION-BAR	<p>Error in the take-up tension bar.</p> <ul style="list-style-type: none"> <li>The tension bar origin could not be found.</li> <li>No change could be seen in the tension bar angle.</li> </ul>	<ul style="list-style-type: none"> <li>Check the set state of the media.</li> <li>Make sure that the media can be wound using the manual SW. Also, make sure that the tension bar rises.</li> </ul> <p>If it does not rise, adjust the counterweight. (☞ P.2-11, P.2-12)</p>
ERROR 425 Take-UP WRONG	<p>A problem has occurred in the take-up tension bar.</p> <ul style="list-style-type: none"> <li>The tension bar control position has deviated from the lowest point for a certain period.</li> </ul>	
ERROR 429 Take-UP LimitDETECT	<p>Limit position of the take-up tension bar has been detected.</p> <ul style="list-style-type: none"> <li>The tension bar control position has deviated from the highest point for a certain period.</li> </ul>	
ERROR 44f Take-UP Roll Sns Err	<p>Roller sensor abnormality</p> <ul style="list-style-type: none"> <li>The roller sensor cannot be correctly read.</li> </ul>	<ul style="list-style-type: none"> <li>Confirm that the take-up unit of machine setup and take-up tension bar setting are ON. (☞ P.3-16)</li> <li>Check the set state of the media.</li> <li>Confirm that the winding unit operates using the manual SW.</li> </ul>
ERROR 505 MEDIA JAM	The media jam occurs.	<ul style="list-style-type: none"> <li>Remove the media and reset it.</li> </ul>
ERROR 509 HDC POSCNT	An error occurred in the control position.	<ul style="list-style-type: none"> <li>Turn off the power on the machine and turn it on after a while.</li> <li>When displaying again, contact your local distributor, our sales office, or service center.</li> </ul>
ERROR 50a Y ORIGIN	Y-origin could not be detected.	
ERROR 50f L-SCALE BLACK	Abnormal linear scale.	
ERROR 52c MEDIA WIDTH SENSOR	The media width could not be correctly read.	<ul style="list-style-type: none"> <li>Check the media set position. (☞ P.2-4)</li> <li>Clean the media sensor. (☞ P.4-3)</li> <li>Turn off the power on the machine and turn it on after a while.</li> </ul>
ERROR 516 MEDIA SET POSITION R	The media is set outside the proper area.	<ul style="list-style-type: none"> <li>Check the media set position. (☞ P.2-5)</li> </ul>

Message	Cause	Solution
ERROR 528 PUMP MOTOR SENSOR	Pump sensor detection error	<ul style="list-style-type: none"> <li>Turn off the power on the machine and turn it on after a while.</li> </ul> When displaying again, contact your local distributor, our sales office, or service center.
ERROR 52f CARRIAGE ORG	The carriage control origin is not set.	<ul style="list-style-type: none"> <li>Contact your local distributor, our sales office, or service center.</li> </ul>
ERROR 530 STATION ORG	The station control origin is not set.	
ERROR 536 STATION LOCK	An error was detected in station operation.	<ul style="list-style-type: none"> <li>Turn off the power on the machine and turn it on after a while.</li> </ul> When displaying again, contact your local distributor, our sales office, or service center.
ERROR 537 MAINT.WASH SHUTTER	An error was detected in cleaning solution shutter operation.	
ERROR 602 CARTRIDGE END	Ink end (cannot be used, can only be used when cleaning with the 4-color ink set)	<ul style="list-style-type: none"> <li>Replace with new ink.</li> </ul>
ERROR 608 WRONG INK IC	The ink pack IC chip cannot be correctly read.	<ul style="list-style-type: none"> <li>Make sure that the cartridge is ink IC chip inserted.</li> <li>Reinsert the ink IC chip.</li> <li>Turn off the power on the machine and turn it on after a while.</li> </ul> When displaying again, contact your local distributor, our sales office, or service center.
ERROR 627 RE-INSERT CARTRIDGE	There is a slot in which the ink IC chip has not been inserted more than a certain time.	<ul style="list-style-type: none"> <li>Set a ink IC chip.</li> </ul>
ERROR 628 WRONG INK CARTRIDGE	A problem has occurred in the ink pack IC chip information. The used count has exceeded the prescribed value.	<ul style="list-style-type: none"> <li>Make sure there is no nozzle clogging.</li> </ul>
ERROR 63c INK REMAIN ZERO	Remaining ink is 0 in the cartridge (ink end/ only when the 4-color ink set is used))	<ul style="list-style-type: none"> <li>Replace with new ink.</li> </ul>
ERROR 64C NCU ERROR	The nozzle check has been suspended due to some problem.	<ul style="list-style-type: none"> <li>Turn off the power on the machine and turn it on after a while.</li> </ul> When displaying again, contact your local distributor, our sales office, or service center.
ERROR 650 NCU CONECT	The NCU unit is not connected.	
ERROR 651 REPLACE NCU	The NCU sensor sensitivity is too low to correctly judge nozzle missing. The nozzle check function cannot be used.	<ul style="list-style-type: none"> <li>The NCU needs to be replaced. Contact your local distributor, our sales office, or service center.</li> </ul>
ERROR 652 NCU NZK CHK (HW)	The NCU cannot correctly recognize the ink discharge, because there are frequent nozzle missing and ink droplet misalignment.	<ul style="list-style-type: none"> <li>Check the state of the nozzles, and if there are frequent nozzle missing and ink droplet misalignment, conduct cleaning to restore.</li> </ul>
ERROR 653 NCU NZK CHK (MARK)		
ERROR 654 NCU CENTER POS	Adjustment of the discharge position to the NCU has failed.	
ERROR 655 NCU FLUSH POS		

Message	Cause	Solution
ERROR 656 NCU SN ADJUST	Sensor sensitivity adjustment has failed.	<ul style="list-style-type: none"> <li>Check the state of the nozzles, and if there are frequent nozzle missing and ink droplet misalignment, conduct cleaning to restore. If the same error message still appears after restoring the state of the nozzles, contact your local distributor, our sales office, or service center.</li> </ul>
ERROR 657 REPLACE NCU INK PAD	The NCU ink pad is full.	<ul style="list-style-type: none"> <li>Contact your local distributor, our sales office, or service center.</li> </ul>
ERROR 658 NCU SENSOR LV LOW	THE sensitivity level of the NCU sensor is low.	<ul style="list-style-type: none"> <li>Replacement of the NCU is recommended. Contact your local distributor, our sales office, or service center.</li> </ul>
ERROR 65b NCU Sens Adj Err H	The sensitivity level of the sensor cannot be adjusted.	
ERROR 65c NCU Sens Adj Err L		
ERROR 702 THERMISTOR CONNECT	The thermistor connection of a heater is defective.	<ul style="list-style-type: none"> <li>Turn off the power on the machine and turn it on after a while. When displaying again, contact your local distributor, our sales office, or service center.</li> </ul>
ERROR 710 HEATER TEMP ERROR	The temperature abnormality of the heater has been detected. When this error occurred and if the temperature abnormality cannot be resolved, the power supply of the machine is forcibly turned off.	
ERROR 71b FAN HEATER ERROR	Power of optional drying heater is not turned on.	<ul style="list-style-type: none"> <li>Please make sure this unit and the optional heater is properly connected.</li> </ul>
	Detect abnormal temperature of the optional drying heater.	
	Connection of the optional drying heater can not be confirmed.	
	Cover of the optional drying heater is open.	
ERROR 901 INVALID OPERATION	Due to a certain error, the function cannot be performed.	<ul style="list-style-type: none"> <li>Return to the local screen, check the error status and take a countermeasure.</li> </ul>
ERROR 902 DATA REMAIN	There remains received data that has not yet been printed.	<ul style="list-style-type: none"> <li>Execute the data clear function. (☞ P.2-19)</li> </ul>
ERROR 90d NO HEAD SELECT	An error occurred in the mounted heads.	<ul style="list-style-type: none"> <li>Turn off the power on the machine and turn it on after a while. When displaying again, contact your local distributor, our sales office, or service center.</li> </ul>
ERROR 90f PRINT AREA SHORT	The media width or the media length required for printing is not enough.	<ul style="list-style-type: none"> <li>Change the media to the one with enough width or length.</li> <li>When the media width narrows because the origin moved, slide the origin to the right to widen the effective media width.</li> </ul>
ERROR 91a ADJUST HEAD HEIGHT	The head height setting saved in the machine and the current head height do not match.	<ul style="list-style-type: none"> <li>Set the head height. (☞ P.2-4)</li> </ul>
ERROR 04 PARAM ROM	An error occurred in the main PCB FROM.	<ul style="list-style-type: none"> <li>Turn off the power on the machine and turn it on after a while. When displaying again, contact your local distributor, our sales office, or service center.</li> </ul>



Message	Cause	Solution
ERROR d01 HCB POWER [1234]	An error occurred in the power supply of the HCB PCB.	<ul style="list-style-type: none"> <li>Turn off the power on the machine and turn it on after a while.</li> </ul> When displaying again, contact your local distributor, our sales office, or service center.
ERROR d02 HCB COMMON [1234]	An error was detected in the HCB PCB.	
ERROR d03 HCB HARD [1234]		
ERROR d04 HCB CMD [1234]	An error was detected in the HCB PCB communication.	
ERROR d05 HCB WFM [1234]	An error was detected in the waveform being printed.	
ERROR d06 HCB VUP [1234]	A failure to update the HCB PCB was detected.	
ERROR d07 HCB FAN [1234]	An error occurred in the HCB board fan.	
ERROR d08 HCB UKNWN [1234]	An unknown error was detected from the HCB board.	
ERROR d09 HD MEMORY [1234]	An abnormality was detected from the head built-in memory.	
ERROR d0a HCB BUSY [1234]	An error occurred in the communication between the HCB board and the slider P board.	

## SYSTEM HALT

Message	Solution
SYSTEM HALT (*) 000 : MESSAGE	<ul style="list-style-type: none"> <li>Turn off the power on the machine and turn it on after a while.</li> </ul> When displaying again, check the number and contact your local distributor, our sales office, or service center. ("000" is the error No.)
SYSTEM HALT (*) 406 : WIPER ORG	<ul style="list-style-type: none"> <li>Perform cleaning around the wiper.</li> <li>Turn off the power on the machine and turn it on after a while.</li> </ul> When displaying again, check the number and contact your local distributor, our sales office, or service center.



# Chapter 6

## Appendix



### **This chapter**

contains the lists of the specifications and functions of this machine.

Specifications .....	6-2
Machine specifications .....	6-2
Ink specifications .....	6-3
Setting orders depending on ink type .....	6-4
Setting orders of ink cartridges .....	6-4
Sheet for inquiry .....	6-5

# Specifications

## Machine specifications

Item		TS300P-1800
Print head	Method	Drop-on-demand piezoelectric print heads
	Specification	4-Head Inline
Printing mode (scan x feed)		360×360dpi/ 540×360dpi/ 720×720dpi/ 720×1080dpi
Usable inks		9 colors (Y, M, BI, K, LBI, Lm, Lk, FP, FY)
Ink supply		Supplying from ink packs through tubes. Ink pack replacement type: Supplying by Toggle switch over with 2 packs/color (4-colors/6-colors ink set: M, BI 7colors ink set: M)
Capacity of ink pack	4-colors	Y, M, BI, K: 2L-ink pack x 2 for each color
	6-colors	Y, K, LBI, Lm: 2L-ink pack x 1 for each color M, BI: 2L-ink pack x 2 for each color
		Y, K, FP, FY: 2L-ink pack x 1 for each color M, BI: 2L-ink pack x 2 for each color
	7-colors	Y, K, BI, LBI, Lm, Lk: 2L-ink pack x 1 for each color M: 2L-ink pack x 2
8-colors	Y, M, BI, K, LBI, Lm, FP, FY: 2L-ink pack x 1 for each color	
Usable media		Duplex paper
Max. printing width		1,940 mm (76.4 in)
Roll Media size	Maximum	1,950 mm (76.8 in)
	Minimum	210 mm (8.3 in)
	Thickness	1.0 mm or less (0.04 in or less)
	Roll outside diameter <sup>*1</sup>	Paper media: Φ250 mm or less (Φ9.8 in or less) Other media: Φ210 mm or less (Φ8.3 in or less)
	Roll weight <sup>*1, *2</sup>	40 kg or less (88.2 lb or less)
	Roll inside diameter	2 or 3 inches
	Printing surface	Side facing outward
Roll end treatment	The roll end is gently fixed to the core with weak-adhesive tape or weak glue for easy removal.	
Leaf media size	Maximum	1,950 mm (76.8 in)
	Minimum	210 mm (8.3 in)
Margin	Leaf media	Left end and right end: 15 mm (Default) Front: 120 mm Rear: 150 mm (Left end and right end: 0.6 in (Default) Front: 4.7 in Rear: 5.9 in)
	Roll media	Left end and right end: 15 mm (Default) Front: 120 mm Rear: 150 mm (Left end and right end: 0.6 in (Default) Front: 4.7 mm Rear: 5.9 mm)
Distance accuracy	Absolute accuracy	Whichever the larger one of ± 0.3 mm or ± 0.3% of the designated (Whichever the larger one of ± 0.01 in or ± 0.3% of the designated)
	Reproducibility	Whichever the larger one of ± 0.2 mm or ± 0.1% of the designated (Whichever the larger one of ± 0.008 in or ± 0.1% of the designated)
Perpendicularity		± 0.5 mm / 1,000 mm (± 0.02 in / 39.4 in)
Media skew		5 mm or less / 10 m (0.2 in or less / 32.8 ft)
Head height adjustment		2 mm to 7 mm, can be freely adjusted manually (0.08 in to 0.28 in, can be freely adjusted manually)
Cutting of media		Cutting of Y direction by the head cutter. Cutting accuracy (steps): 0.5 mm or less (0.02 in or less)
Media delivery		Take-up device supplied as a standard accessory (switching possible between face in and face out).
Waste ink tank		Bottle type: 2,000 cc (2 liters)
Interface	Print data transmission function	USB 2.0, Ethernet 1000BASE-T
	Mail function	Ethernet 10 BASE-T / 100 BASE-TX / 1000BASE-T
Command		MRL- V

Item		TS300P-1800
Noise	during standby	Less than 58 dB (A) (FAST-A, Front & Rear & Left & Right 1 m (39.4 in))
	during continuous printing <sup>*3</sup>	Less than 65 dB (A)
	during discontinuous printing	Less than 70 dB (A)
Safety Standard		VCCI-Class A, FCC-Class A, UL 60950, CE Marking (EMC, Low Voltage Directive, Machinery Directive, RoHS Directive), CB Report, RoHS
Power		AC100 - 120V/ 200 - 240V 12A/8A 50/60Hz
Power consumption		1,440W(AC100 - 120V), 1,920W (AC 200 - 240V)
Recommended Environment	Available temp.	20 °C to 30 °C (68 °F to 86 °F)
	Humidity	35 to 65% Rh (No condensation)
	Guaranteed temp.	20 °C to 25 °C (68 °F to 77 °F)
	Temperature change	± 10 °C / h or less (± 50 °F / h or less)
	Dust	Equivalent to normal office level
	Highest operation height	2,000 m (6,561.7 ft)
Weight		213 kg (469.6 lb)
Outside dimensions	Width	3,197 mm (125.9 in)
	Depth	842 mm (33.1 in)
	Height	1,857 mm (73.1 in)

\*1. It is outside diameter and weight after take-up media.

\*2. Without deflection of the roll when it is retained at both ends.

\*3. Operating Condition: Full load Measuring Method: According to clause 1.7.4.2 of Machinery Directive 2006/42/EC

## Ink specifications

Item		Sublimation dye ink
Supply		2 liters ink pack
Color		Black ink pack (B) Blue ink pack (BI) Magenta ink pack (M) Yellow ink pack (Y) Light blue ink pack (LBI) Light magenta ink pack (Lm)
		Light black ink pack (Lk) Fluorescent yellow ink pack (FY) Fluorescent pink ink pack (FP)
Ink capacity		2 liters
Shelf life		The period is printed on the ink pack. Within three months after opening the package even in the available period.
Storage temperature	Storage	Average daily temperature: 10 to 35°C (50 to 95°F) Be sure to keep a vessel in the airtight condition. Be sure to keep a vessel in a dry, well-ventilated, cool and dark location.
	Transportation	0 to 40 °C (32 to 104 °F) Avoid the condition lower than -0 °C (32 °F) and higher than 40 °C (104 °F).



- Do not disassemble ink packs and 2L eco case and do not refill them with ink.
- Ink could freeze if kept in a cold place for an extended period.
- When aqueous ink is used, if the ink freezes, the quality is changed and the ink becomes unusable. Store the ink in an environment that will not freeze the ink.

# Setting orders depending on ink type

The setting value and the setting orders of the ink cartridges differ depending on the ink type you use.

## Setting orders of ink cartridges

The orders of ink cartridges set in the ink station differ depending on the ink set you use.



- Set the ink cartridge according to the cartridge label under the ink station.

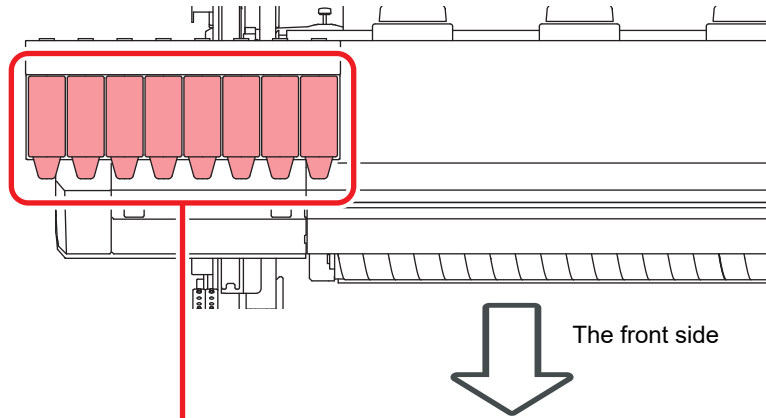

<b>4-colors model</b>	Sublimation dye ink	M	M	BI	BI	Y	Y	K	K
<b>6-colors model</b>	Sublimation dye ink	M	M	BI	BI	Y	K	LBI	Lm
		M	M	BI	BI	Y	K	FP	FY
<b>7-colors model</b>	Sublimation dye ink	M	M	BI	Lk	Y	K	LBI	Lm
<b>8-colors model</b>	Sublimation dye ink	M	FP	BI	FY	Y	K	LBI	Lm

# Sheet for inquiry

Use this sheet for troubles and abnormal functions of the machine.  
Fill in the following necessary items, and then fax the sheet to our sales office.

<b>Company name</b>	
<b>Person in charge</b>	
<b>Telephone number</b>	
<b>machine model</b>	
<b>Operating OS</b>	
<b>Machine information *1</b>	
<b>Error message</b>	
<b>Contents of inquiry</b>	

\*1. Refer to "Confirming Machine information" of "Convenient using" then fill in necessary information. (☞ P.3-28)





# **TS300P-1800 Operation Manual**

---

---

May, 2021

MIMAKI ENGINEERING CO.,LTD.  
2182-3 Shigeno-otsu, Tomi-shi, Nagano 389-0512 JAPAN

---

---

D202869-17-08052021

