

# APC-130

## Quick Reference

### Table of Contents

---

---

CAUTION.....	2
Safety Precautions.....	3
Suitable Place for Installing APC-130 .....	5
Main Body Size and Area Required for Installation .....	6
When the sheet is misaligned .....	7
The cutter becomes dull in a short time .....	10
Settable paper .....	10
When you replace pen line .....	10
When you cut off the sheet after cutting .....	11
The end point does not match the starting point when you performed cutting .....	12
Consumed Power .....	12
Need for feeding sheet before plotting .....	12
When cutting, there are some places not to be cut .....	13
The motor alarm and the over current have occurred .....	14
Plotting does not match the cut line .....	14
Paper jam has occurred .....	15
What is HALF CUT? .....	16
The pattern comes off easily .....	17

# CAUTION

---

## ● CAUTION

DISCLAIMER OF WARRANTY : THIS LIMITED WARRANTY OF MIMAKI SHALL BE THE SOLE AND EXCLUSIVE WARRANTY AND IS IN LIEU OF ALL OTHER WARRANTIES, EXPRESS OR IMPLIED, INCLUDING, BUT NOT LIMITED TO, ANY IMPLIED WARRANTY OF MERCHANTABILITY OR FITNESS, AND MIMAKI NEITHER ASSUMES NOR AUTHORIZES DEALER TO ASSUME FOR IT ANY OTHER OBLIGATION OR LIABILITY OR MAKE ANY OTHER WARRANTY OR MAKE ANY OTHER WARRANTY IN CONNECTION WITH ANY PRODUCT WITHOUT MIMAKI'S PRIOR WRITTEN CONSENT. IN NO EVENT SHALL MIMAKI BE LIABLE FOR SPECIAL, INCIDENTAL OR CONSEQUENTIAL DAMAGES OR FOR LOSS OF PROFITS OF DEALER OR CUSTOMERS OF ANY PRODUCT.

## ● Requests

- This Operation manual has been carefully prepared for your easy understanding. However, please do not hesitate to contact a distributor in your district or our office if you have any inquiry.
- Description contained in this Operation manual are subject to change without notice for improvement.
- Generally, names and designations referred to in this Operation manual are trade marks or registered trade marks of the manufacturers or suppliers.

## ● FCC Statement (USA)

This equipment has been tested and found to comply with the limits for a Class A digital device, pursuant to Part 15 of the FCC Rules. These limits are designed to provide reasonable protection against harmful interference when the equipment is operated in a commercial environment. This equipment generates, uses and can radiate radio frequency energy and, if not installed and used in accordance with the Operation manual, may cause harmful interference to radio communications. Operation of this equipment in a residential area is likely to cause harmful interference in which case the user will be required to correct the interference at his own expense.



- In the case where MIMAKI-recommended cable is not used for connection of this device, limits provided by FCC rules can be exceeded. To prevent this, use of MIMAKI-recommended cable is essential for the connection of this plotter.

## ● Interference to televisions and radios

The product described in this manual generates high frequency when operating. The product can interfere with radios and televisions if set up or commissioned under improper conditions. The product is not guaranteed against any damage to specific-purpose radio and televisions. The product's interference with your radio or television will be checked by turning on/off the power switch of the product.











In the event that the product is the cause of interference, try to eliminate it by taking one of the following corrective measures or taking some of them in combination.

- Change the orientation of the antenna of the television set or radio to find a position without reception difficulty.
- Separate the television set or radio from this product.
- Plug the power cord of this product into an outlet which is isolated from power circuits connected to the television set or radio.







# Safety Precautions

## ● Pictorial signs







Pictorial signs are used in this Operation manual for safe operation and for prevention of damage to the plotter. Pictorial signs and their meanings are given below. Read and fully understand before reading the text.

	Failure to observe the instructions given with this symbol can result in death or serious injuries to personnel. Be sure to read and observe the instructions for proper operation.
	Failure to observe the instructions given with this symbol can result in injuries to personnel or damage to property.
	This symbol indicates that the information is helpful in proper operation of the plotter.
	This symbol indicates that it is important to know of the information on proper operation of the plotter. Use this information for your operation.
	Indicates the reference page for related contents.
	The symbol “  ” indicates that the instructions must be observed as strictly as the CAUTION instructions (including DANGER and WARNING instructions). A sign representing a precaution (the sign shown at left warns of hazardous voltage) is shown in the triangle.
	The symbol “  ” indicates that the action shown is prohibited. A sign representing a prohibited action (the sign shown at left prohibits disassembly) is shown in or around the circle.
	The symbol “  ” indicates that the action shown must be taken without fail or the instructions must be observed without fail. A sign representing a particular instruction (the sign shown at left instructs to unplug the cable from the wall outlet) is shown in the circle.

● **Warning for Use**

 <b>WARNING</b>	
<p><b>Do not disassemble or remodel the plotter</b></p>  <ul style="list-style-type: none"> <li>• Never disassemble or remodel the plotter. Disassembly or remodeling can result in an electric shock or breakdown of the machine.</li> </ul>	<p><b>Avoid locating the plotter in a damp environment</b></p>  <ul style="list-style-type: none"> <li>• Do not use the plotter in a damp place. Do not splash water onto the machine. Use in such an environment can give rise to fire, electric shocks or breakdown of the plotter.</li> </ul>
<p><b>In case abnormal event occurs</b></p>  <ul style="list-style-type: none"> <li>• Use of the plotter under an abnormal condition where the device produces smoke or strange smell can result in fire or electric shocks. If such an abnormality is found, be sure to turn off the power switch immediately and unplug the cable from the wall outlet. Check first that the plotter no longer produces smoke, and contact your distributor for repair. Never repair your plotter by yourself since it is very dangerous for you to do so.</li> </ul>	<p><b>Handling of the power cable</b></p>  <ul style="list-style-type: none"> <li>• Use the supplied power cable.</li> <li>• Take care not to damage, break or work upon the power cable. If a heavy material is placed on the power cable, or if it is heated or pulled, the power cable can break, thus resulting in fire or electric shocks.</li> </ul>  <ul style="list-style-type: none"> <li>• Plug the power cable plug into a grounded power outlet. Otherwise there is a risk of failure, electric shock, or fire.</li> <li>• When installing electrical outlets, perform grounding work to prevent electric shock. All electrical work (Class C grounding work; formerly Type 3 grounding work) must be handled by a licensed electrician.</li> </ul>

● **Precaution for Use**

 <b>CAUTION</b>	
<p><b>Be careful with the movable parts</b></p>  <ul style="list-style-type: none"> <li>• Do not touch the rolling grit roller; otherwise, you may hurt your fingers or tear off your finger nails.</li> </ul>  <ul style="list-style-type: none"> <li>• Keep your head and hands away from any moving parts during cutting (plotting) operation; otherwise, you may get your hair caught in the machine or get injuries.</li> </ul>  <ul style="list-style-type: none"> <li>• Wear proper clothes. (Do not wear loose-fit clothes or accessories). Bind a long hair.</li> </ul>	<p><b>Sheets</b></p>  <ul style="list-style-type: none"> <li>• Use a strongly curled sheet after removing curl. Heavily curled sheet affects the cutting (plotting) result.</li> </ul> <p><b>Caution with cutters</b></p>  <ul style="list-style-type: none"> <li>• Do not touch the cutter blade, which is very sharp.</li> <li>• Do not shake or swing the cutter holder; otherwise, the blade may come off.</li> </ul> <p><b>Other usage precautions</b></p>  <ul style="list-style-type: none"> <li>• Keep children away from this machine.</li> </ul>

# Suitable Place for Installing APC-130

● Prepare the place where meets conditions below:

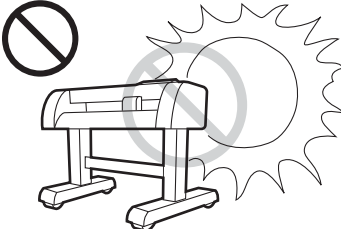
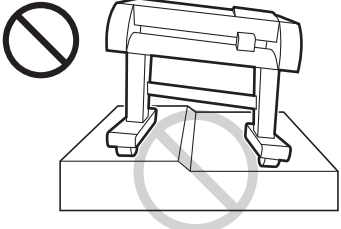
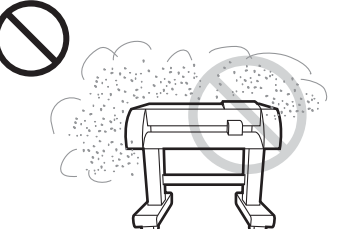
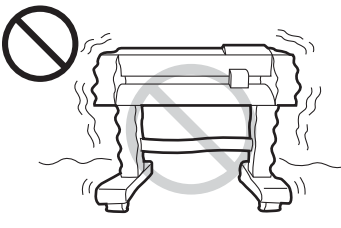
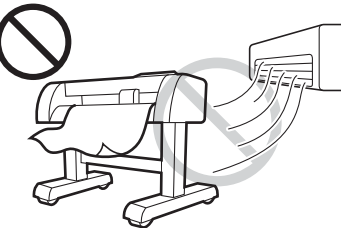
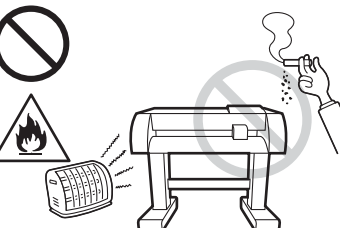
A place exposed to direct sunlight	On an inclined surface	A place gets dusty
		
A place that vibrates	A place exposed to direct air flow from an air conditioner or the like	Around a place where flame is used
		
A place where temperature or humidity varies significantly		
<p>! Use the plotter under the following environmental conditions:</p> <p>Operable environment :            Temperature 5 to 35 °C/ Humidity 35 to 75 % (Rh) (with no dew condensation)</p> <p>Accuracy assurance environment :            Temperature 16 to 32 °C/ Humidity 45 to 65 % (Rh) (with no dew condensation)</p>		
Other installation precautions		
<p>⊘ Avoid installing this machine in locations accessible to children.</p>		

# Main Body Size and Area Required for Installation

The main body size of APC-130 and the area required for installation is as below:

## Outside dimensions of APC-130

Width	Depth	Height	Gross weight
1825mm	700 to 1110 *1mm	1217mm	75kg

\*1.Size when the sheet basket of the front and the rear is spread out up to max.

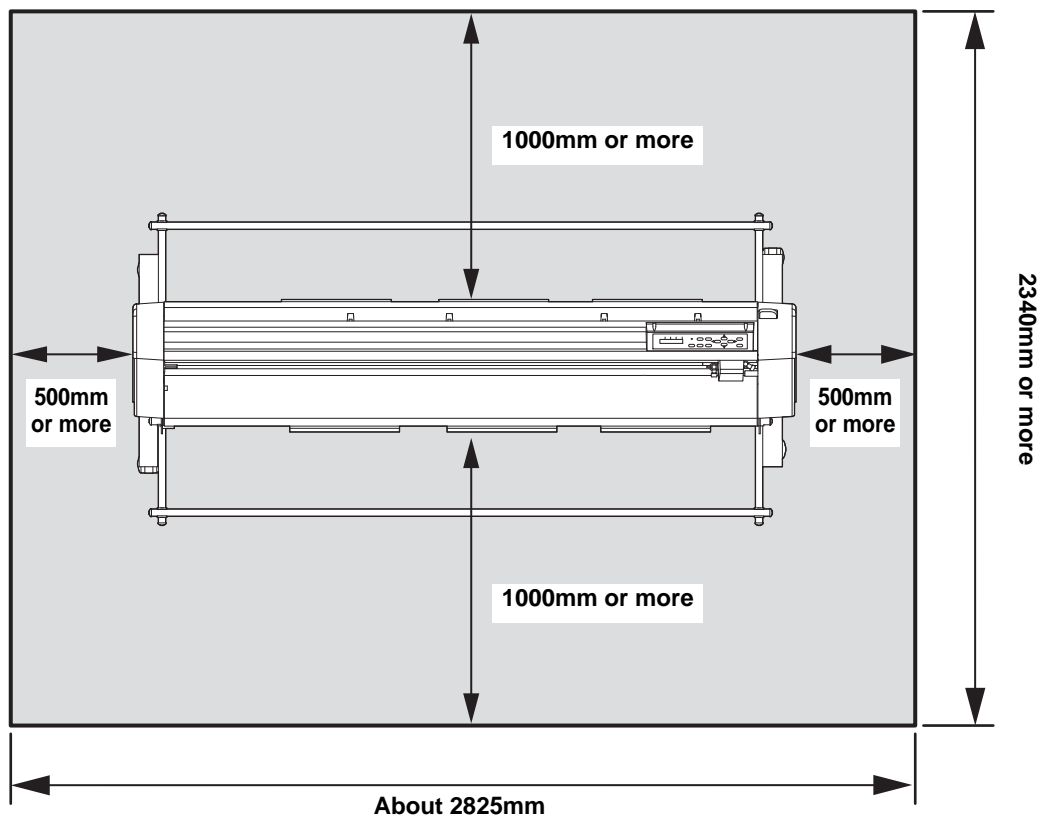

**Important!**

- Ensure the space for installing the main body and the work space required for replacing the roll sheet etc.
- In addition to the space for APC-130, the space for installing the computer for output.

# When the sheet is misaligned

Check each item below:

**Check whether it is used under the environment recommended by our company.**

Referring to **P.5** "", check whether APC-130 is used under the environment recommended by our company.

**Important!**

- Especially, check the temperature and the humidity. On a rainy day, the sheet may expand and shrink much, and it may cause sheet misalignment. Use it under the environment with little change in the temperature and the humidity.

**Check whether the pinch roller is set at the proper position.**

**(1) Check that the pinch roller matches white seal position.**

By matching the pinch roller with white seal, the grit roller position matches the pinch roller position, and the sheet can be fed normally.

**(2) Check that four pinch rollers hold the sheet.**

If the number of pinch rollers is less, the stable feeding cannot be performed.

**(3) Check that the pinch roller position at the right end and the left end.**

Check that the pinch roller at the right end and the left end are on the position from 5mm and more inside from the sheet end.

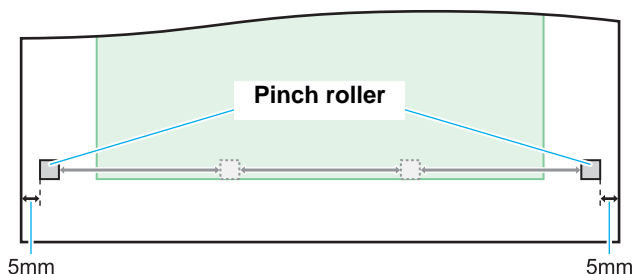

**Check whether the clamp power setting is proper.**

The clamp power setting shall be the same both for right and left. Otherwise, the stable sheet feeding cannot be performed.

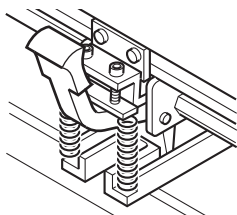

**High mode**

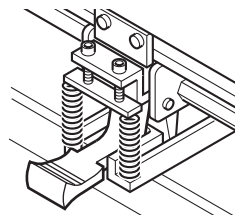

**Low mode**

**Reference for clamp setting**

Paper type	Thin paper	Standard paper	Thick paper
<b>Clamp power</b>	Low/Low/Low/Low	High/Low/Low/High	High/Low/Low/High

**Check whether there is no deformation of the pinch roller.**

If there is dirt or ink blot on the pinch roller, or the pinch roller has been damaged or has become deformed, the sheet cannot be fed normally.

→ Remove dirt or ink blot.

→ If it has been damaged or has become deformed, contact a distributor in your district or our office to call for service.

# When the sheet is misaligned (continued)

**Check whether a piece of paper is not wound on the grit roller.**

After removing the clogged sheet etc., a piece of paper may be wound on the grit roller. Turn OFF the power supply, and rotate the grit roller manually to remove the paper.  
At this time, be careful not to clip your hand or get injured on it.

If the sheet has not been set properly, the sheet feeding may be misaligned due to the difference between the tensions of right and left of the sheet etc. Check the following items:

**(1) Check that the media edge is not in the status of the bad example below.**

**Good example**

All edge surfaces match each other.



**Bad example**

The edge surfaces are misaligned, and it looks like a bamboo shoot.



**(2) Check whether you set the sheet straight**

**Good example**

- Seen from the rear side, the tension of right and left of the sheet is the same.
- When you feed the sheet, the roll edge surface matches the sheet edge.

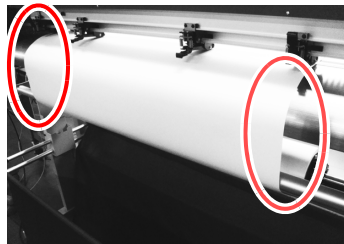

The tension of right and left of the sheet is almost the same.



When you feed the sheet, the roll edge surface matches the sheet edge.

**Bad example**

- Seen from the rear side, either of right or left of it sags.
- When you feed the sheet, the roll edge surface does not match the sheet edge.

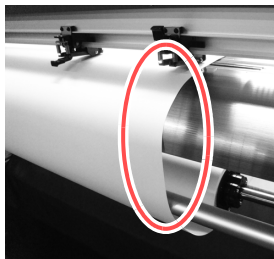

Either of right or left of it sags.

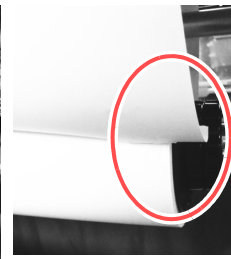

The roll edge surface does not match the sheet edge.

**Check whether the sheet is set properly.**



# When the sheet is misaligned (continued)

**Check whether the sheet is set properly.**

**(3) Check whether you perform pre-feed**

Be sure to perform pre-feed. Roll sheet may expand or shrink not a little due to the environment change by changing its status of being taken-up to sagging. Because of this, the position relationship at the end of cutting may be different from that at the start, or, the paper may skew and slant.

For the pre-feed setting method, refer to the **Operation manual chapter 3 “Setting the PRE FEED”**.

**(4) Check whether the sheet does not float at the sheet detection.**

If the sheet floats, reset it.

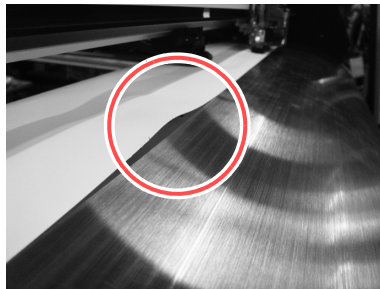

**(5) Check whether the roll sheet that has not been wound tightly (sagging) is not used.**

If you rewind the roll sheet repeatedly, the sheet may sag due to expansion and contraction of the media. If you set the sheet with surface waviness, even tension cannot be applied on both right and left, and therefore, the stable feeding cannot be performed.

**Check whether a usable sheet is used.**

Referring to the **Operation manual chapter 5 “Specification-Settable sheet”**, check that it is a usable sheet with APC-130.

If you use a sheet other than the specified, the stable feeding may not be performed.

A heavy sheet is used.

When you use a heavy sheet, set “Setting the SHEET TYPE” of the Setting function to “HEAVY”. (For the setting method, refer to the Operation manual.)

**Check whether continuous cutting has not been performed.**

If you perform continuous cutting, the sheet may be slanted gradually. In such a case, after adjusting misalignment of the sheet using the hold function (refer to the Operation manual), you can cut continuously.

**Check whether the cut pattern does not come off.**

When the cut pattern comes off as described in the photo below, it may impact on the feeding.



## The cutter becomes dull in a short time

Check each item below:

<b>Check the sheet you use.</b>	When the sheet is hard or thick, or due to the sheet composition, the life of the blade may shorten.
<b>Is the proper cutting condition set?</b>	First, make the cutting pressure (PRESS) stronger. (Refer to the <b>Operation manual chapter 2 “Set the Tool Conditions”</b> .) Even if you made the cutting pressure (PRESS) stronger and when you cannot cut, adjust the protruding amount of the blade edge.
<b>Is the protruding amount of the blade edge proper?</b>	Adjust the protruding amount of the blade edge. (Use the value of sheet thickness +0.3mm as a reference.)  <div style="display: flex; align-items: center;"> <div style="border: 1px solid black; border-radius: 50%; padding: 2px; margin-right: 10px;">Important!</div> <ul style="list-style-type: none"> <li>If the protruding amount of the blade edge is too much, the life of the blade may shorten. In addition, by hitting sheet, it may cause a paper jam, or, it may cut outside the targeted place. Adjust the protruding amount of the blade edge properly.</li> </ul> </div>

## Settable paper

The settable paper size is as below:

Type of sheet	Sheet width	Weight	Roll inside diameter	Roll inside diameter
Roll paper (for apparel 64 to 180g/m <sup>2</sup> )	890 to 1400mm	20kg or less	φ200mm or less	3 inch

**Important!**

- You cannot use a sheet which is left over (a piece of cut paper).

## When you replace pen line

The pen line can be replaced on the customer side.

Purchase the pen line of the Product No. below, and replace it by referring to the **Operation manual chapter 1 “Pen line”**.

Pen line APC : Product No. SPC-0725

# When you cut off the sheet after cutting

There are two methods to cut off the roll sheet:

(1) By using the “automatic cutting function”, when cutting has been completed, cut off the sheet automatically.

(For the “automatic cutting function” setting method, refer to the **Operation manual chapter 3 “Setting the AUTO CUT”**.)

(2) When you set the “automatic cutting function” to “OFF”, cut off the sheet manually with the procedures below (paper cutting function).



- When you cut off the roll sheet in APC-130, use the cutter attached on the carriage.

## ● Paper cut function

Cut off the sheet on the current tool position.

When you use the paper cut function, the device will cut up to 80mm from outside the pinch roller.

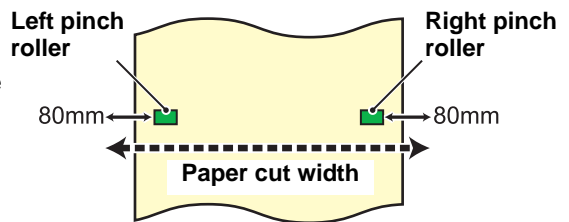

1

Press the **REMOTE** key to select LOCAL mode.

CUT1 20 050 0.30

- Check that cutting (plotting) does not start even if you press the **REMOTE** key and the device enters into the remote mode in advance.

2

Press **▲ ▼ ◀ ▶** to enter into the jog mode.

0.0 0.0

- When you press any jog key, the device enters into the jog mode.

3

By pressing **▲ ▼**, feed the sheet to the position where you cut the sheet off.

**▲** : Moves the sheet to the rear side.

**▼** : Moves the sheet to the front side.

The cutter cuts the sheet while passing the position described with the dotted line in the right photo. Move the sheet to the position where you cut.

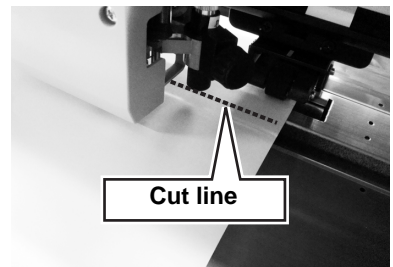

4

Press the **FUNCTION** key, and then press the **ENTER/HOLD** key.

\*\* PAPER CUT \*\*

- Cut the sheet off.
- When the cutting has been completed, the current mode returns to LOCAL mode.



- When the pre-feed setting is valid, the pre-feed operation is performed and then the device returns to the local mode.

## The end point does not match the starting point when you performed cutting

If the end point does not match the starting point when cutting, check the items below:

<b>Isn't the sheet misaligned?</b>	By referring to <b>P.11 "When you cut off the sheet after cutting"</b> , adjust the sheet misalignment.
<b>The sheet has expanded and shrunk due to the temperature/ humidity.</b>	The sheet may expand and shrink due to the temperature/ humidity. By referring to <b>P.5 "Suitable Place for Installing APC-130"</b> , use APC-130 under the specified environment.  In addition, by acclimating the sheet to the using environment, you can prevent it from expanding/ shrinking. Using the pre-feed function (referring to the <b>Operation manual chapter 3 "Setting the PRE FEED"</b> ), acclimate the sheet to the using environment before cutting.
<b>Is the cutting condition proper?</b>	By referring to the <b>Operation manual chapter 2 "About Tool Condition"</b> , check that PRESS/ SPEED/ OFFSET are proper.
<b>Set [DUMMY CUT] to "ON".</b>	By performing dummy cut (aligning blade edge direction), the quality at the start of cutting can be improved. For the setting method of dummy cut, refer to the <b>Operation manual chapter 3 "Setting the DUMMY CUT"</b> .

## Consumed Power

Max. consumed power is 145VA and below.

## Need for feeding sheet before plotting

The reason why the pre-feed is performed to feed the sheet before plotting is as below:

<b>Reduction of sheet expansion and contraction due to environmental change</b>	Roll sheet may expand or shrink not a little due to the environment change by changing its status of being taken-up to sagging. Because of this, the position relationship at the end of cutting may be different from that at the start, or, the paper may skew and slant.
<b>By loosening the media in advance, shock when the sheet is fed from the roll can be reduced.</b>	When the pinch roller and the grit roller feed the sheet forward, if it is pulled out in the roll status, the sheet or plotting may be misaligned due to the shock.



- For the pre-feed setting, refer to [Feed count] and [Waiting time] described in "Reference for cutting condition-Other setting" of the **Operation manual chapter 2 "Set the Tool Condition"**.

# When cutting, there are some places not to be cut

Check each item below:

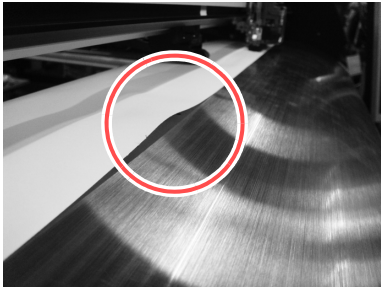
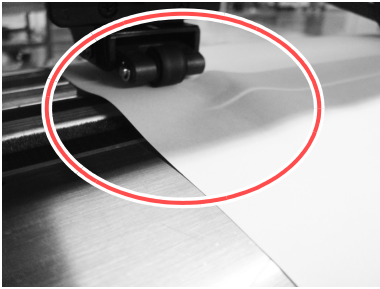
<p><b>Is the toll set surely?</b></p>	<p>If the toll has not been set surely, the tool may float and it may cause being patchy or the part not to be cut.</p>
<p><b>Is the protruding amount of the blade edge proper?</b></p>	<p>If it is too much or too less, adjust it to the proper amount. (Use the value of sheet thickness +0.3mm as a reference.)</p>
<p><b>Isn't the blade edge damaged or worn away?</b></p>	<p>If the blade edge is damaged or worn away, even if you increase the cutting pressure (PRESS), the cut surface fuzzes and you cannot cut beautifully. In such a case, replace the blade edge. For the replacing method, refer to the <b>Operation manual chapter 2 "How to install a cutter"</b>.</p>
<p><b>Is the proper cutting condition set?</b></p>	<p>It is necessary to change the cutting condition depending on the sheet to use. By referring to the <b>Operation manual chapter 2 "Set the Tool Conditions"</b>, set the cutting condition suitable for the sheet.</p>
<p><b>Did you set the DUMMY CUT?</b></p>	<p>By DUMMY CUT (aligning the blade edge direction), you can improve the cutting quality.</p>
<p><b>Doesn't the sheet float?</b></p>	<p>Due to the temperature or the humidity, the sheet may float described in the photo. Referring to <b>P.5 "</b>", check whether APC-130 is used under the environment recommended by our company.</p> <p><b>Important!</b></p> <ul style="list-style-type: none"> <li>• Especially, check the temperature and the humidity. On a rainy day, the sheet may expand and shrink much, and it may cause sheet misalignment. Use it under the environment with little change in the temperature and the humidity.</li> </ul> <div style="display: flex; justify-content: space-around;">   </div>

## The motor alarm and the over current have occurred

An error has occurred because too much load was applied to the motor to feed the media (A motor) and the motor to move the pen (cutter blade) right and left (B motor).

**(1) If Error 40 A motor alarm and Error 42 A over current are displayed, check the following items:**

<b>Is the specified sheet used?</b>	Check that the weight, the thickness and the width are within the specification. If you use a roll sheet other than specified, stable feeding cannot be performed. For the roll sheet specification, refer to <b>P.10 "Settable paper"</b> .
<b>Isn't a heavy roll sheet used?</b>	When you use a heavy roll sheet, set "Sheet setting" of the setting function to "HEAVY". For the setting method, refer to the <b>Operation manual chapter 3 "Setting the SHEET TYPE"</b> .
<b>Has paper jam occurred?</b>	By referring to <b>P.15 "Paper jam has occurred"</b> , remove the jammed paper.

**(2) If Error 41 B motor alarm and Error 43 B over current are displayed, check the following items:**

<b>Has paper jam occurred?</b>	By referring to <b>P.15 "Paper jam has occurred"</b> , remove the jammed paper.
--------------------------------	---

## Plotting does not match the cut line

### ● The roll sheet has expanded and shrunk

The main cause is that the sheet has expanded and shrunk.

Roll sheet may expand or shrink not a little due to the environment change by changing its status of being taken-up to sagging. Because of this, the position relationship at the end of cutting may be different from that at the start, or, the paper may skew and slant.

By acclimating the sheet to the using environment, you can prevent it from expanding/ shrinking. Be sure to perform "pre-feed" before cutting/ plotting, acclimate the sheet to the using environment.

For the pre-feed, refer to the **Operation manual chapter 3 "Setting the PRE FEED"**.

### ● The roll sheet is misaligned

Because the roll sheet is misaligned, plotting may not match the cut line.

By referring to **P.11 "When you cut off the sheet after cutting"**, adjust the sheet misalignment.

# Paper jam has occurred

When paper jam has occurred, remove the media by following the procedures below:

**1** Raise the clamp.

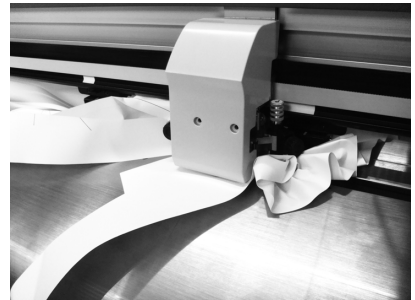

**2** Move the head manually, and remove the media.



- When an error message is displayed on the screen, turn off the power and then turn on it again.

● If paper jam tends to occur, check the following items:

**(1) The media sticks to the platen due to static, and the head may contact with the media**

When you install the device on the carpet etc., static tends to be generated. In addition, when the air is too dry, static tends to be generated. Use the device under the environment where static does not tend to be generated as much as possible.

**(2) When the pattern cut first comes off and the cutter drags it**

As indicated in the right photo, when the pattern cut first comes off, it may impact on feeding as well as it cause paper jam.



- When the cut pattern tends to come off, it is necessary to change the half cut condition. For the half cut, refer to P.16 "What is HALF CUT?"

**(3) When the media fed to the forward direction floats, not to fit into the basket**

As indicated in the photo, when the media piles up in the basket, the media fed to the forward direction may float. Be sure to often remove the media that has already been cut, not to be left in the basket.

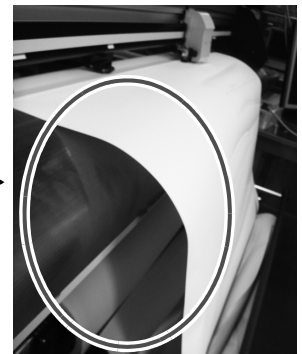

# What is HALF CUT?

Half cut set in APC-130 is explained here.

The cut line of APC-130 is a dotted line with the part to be cut and the part to be left (not to be cut) one after the other to make a pattern easier.

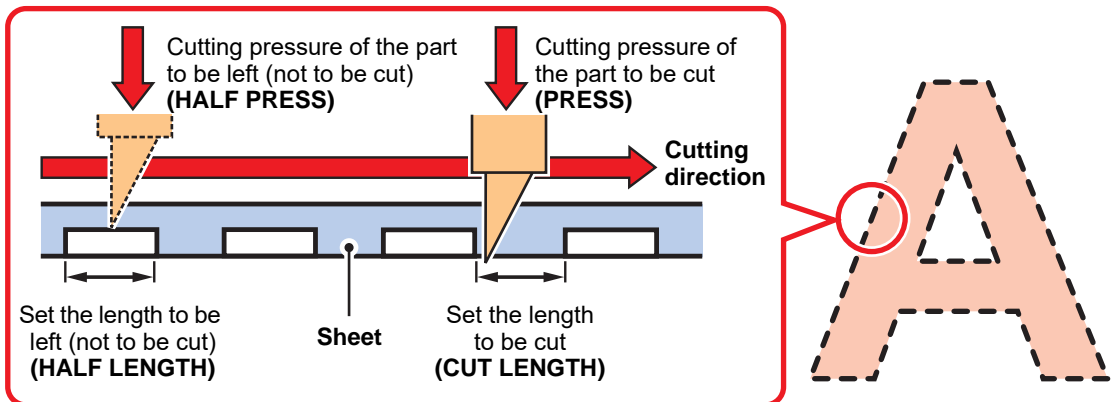

In APC-130, also cut the surface of the part to be left (HALF LENGTH) with light pressure so that the pattern can be removed beautifully after cutting.



**Depending on the setting value of HALF CUT, the pattern tends to come off during cutting. Be careful about it.**

- The pressure of the part to be left (HALF PRESS) is too high.
- The part to be left (HALF LENGTH) is too short.
- The part to be cut (CUT LENGTH) is too long.



**For the setting method of half cut and the reference for the cutting condition, refer to the Operation manual.**

- Setting method of half cut : **Operation manual chapter 2 “Set the Tool Condition”**
- Reference for cutting condition : **“Reference for cutting condition” of the Operation manual chapter 2 “Set the Tool Condition”**



## The pattern comes off easily

When the pattern comes off during cutting, it is necessary to change the half cut condition.

- **Change the HALF CUT setting.**

- (1) **Reduce the HALF PRESS.**
- (2) **Lengthen the HALF LENGTH.**
- (3) **Shorten the CUT LENGTH.**

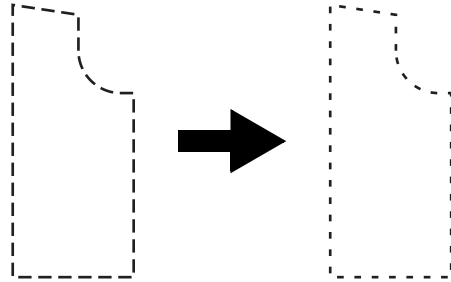

By doing these, the length/ the strength/ the number of the part to be left and joining patterns increase, and it becomes not to come off easily.

For details, refer to **P.16 "What is HALF CUT?"**.

- **When you replace the blade with new one, the device may cut the part to be left.**

Perform test cutting and set the cutting condition again.

For the test cutting method, refer to the **Operation manual chapter 2 "Test Cutting"**.

**Important!**

- Depending on your CAD, the setting in the CAD may have priority.

MEMO

---



